

FESTA®

ПРОФЕСИОНАЛНИ  АЛАТИ

20

23

24



FESTA[®]

Marka visokokvalitetnog ručnog alata za izgradnju, radionicu i baštu

HORIZONT
EXACTA

Marka vrhunskog nivoa kvaliteta

HORIZONT

Marka visokog nivoa kvaliteta i zidarskog osoblja

FESTA
POWER X TOOLS

Sveobuhvatna grupa baterijskih proizvoda koji koriste kvalitetne komponente, najnovije tehnologije i aktuelne trendove u akumulatorskim alatima

FESTA
AQUATIC

Profesionalna zalivna oprema, moderni dizajn, kompatibilan sa Rosa programom

ROSA

Kvalitetni sistemi za zalijevanje i vrtni alat

KDS[®]

Japanski noževi sa dugom tradicijom

KOMELON[®]

Profesional measuring tapes



Profesionalni rezači pločica



Profesionalne vrtno makaze

Lescha

Profesionalne mešalice za beton

Stahlberg

Marka svetskog proizvođača nastavaka za odvijače



Profi testere

AKUMULATORSKI ALATI

2 - 23



4 10 11 12 13 13 14 15 15 18

MERNI ALATI

24 - 57



26 28 31 32 34 35 38 43 44 46 50 56

ALATI

58 - 159



60 70 73 87 101 115 122 129 131 136 140 144 149 155

BURGIJA, ALAT ZA SEČENJE

160 - 241



162 173 178 181 184 194 198 209 210 214 219 222 228 234

GRAĐEVINSKI ALAT

242 - 329



244 256 261 266 272 280 287 300 304 306 310 322 327 328

BASTENSKI ALAT

330 - 397



332 343 345 346 348 364 365 367 372 381 387 389 394 395

GVOŽDJARSKA OPREMA I OSTALI

398 - 431



400 404 406 409 411 412 413 415 417 418 420 426

AUTO

432 - 443

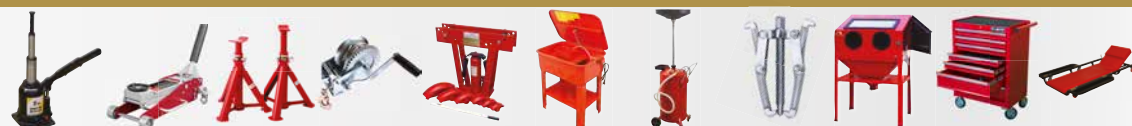

434 435 436 438 439 440 440 441 441 442 443

POPIS ARTIKLA

444 - 456

FESTA

POWER X TOOLS

SHARE
20V

Li-ion
technology



AKUMULATORSKI
ELEKTRIČNI ALATI

2 - 23



BRUSHLESS **SHARE** **Li-ion**
20V *technology*

brzina
0-550 min⁻¹
0-2000 min⁻¹

masa
sa baterijom 2,0 Ah **1,8**
kg

obrtni moment
80 Nm

chuck
2 - 13 mm

sa baterijom 4,0 Ah **2,1**
kg



Set sadrži:
- čekić Bušilica
- 2.0 Ah baterija
- 4.0 Ah baterija
- 2.4 A punjač
- dodatna ručka
- kofer

dodatna ručka

izbor režima
izbor obrtni moment sile



prekidač za brzinu

brzo oslobađanje
chuck head

prekidač smera rotacije

ergonomska gumirana ručka
za udoban i siguran hvat

LED osvetljenje

baterija lock

kuka za kačenje



FESTA
POWER X TOOLS

ČEKIĆ BUŠILICA BEŽIČNI



Br. 28000
specifikacija



BRUSHLESS SHARE 20V Li-ion technology

izbor režima
izbor obrtni moment sile

brzina
0-550 min⁻¹
0-2000 min⁻¹

masa
sa baterijom 2,0 Ah
1,8 kg
sa baterijom 4,0 Ah
2,1 kg

obrtni moment
80 Nm

chuck
2 - 13 mm

Set sadrži:
- čekić Bušilica
- 2.0 Ah baterija
- 2.4 A punjač
- dodatna ručka
- kofer



dodatna ručka

prekidač za brzinu

brzo
oslobađanje
stezna glava

prekidač smera
rotacije

ergonomska gumirana ručka
za udoban i siguran hvat

LED osvetljenje

kuka za
kačenje

baterija lock

FESTA
POWER X TOOLS

ČEKIĆ BUŠILICA BEŽIČNI



Br. specifikacija

28001

2

BRUSHLESS SHARE 20V

izbor režima
izbor obrtni moment sile

brzina
0-550 min⁻¹
0-2000 min⁻¹

masa
bez baterija
1,4 kg

obrtni moment
80 Nm

chuck
2 - 13 mm

Pribor

28080 Baterija 2,0 Ah

28081 Baterija 4,0 Ah

28085 Punjač 2,4 A

28086 Punjač 4,0 A



dodatna ručka

prekidač za brzinu

brzo
oslobađanje
chuck head

pravac
rotacionog prekidača

ergonomska gumirana ručka
za udoban i siguran hvat

LED osvetljenje

kuka za kačenje

FESTA
POWER X TOOLS

ČEKIĆ BUŠILICA BEŽIČNI



*baterija nije uključena

Br. specifikacija

28002



5

SHARE
20V

Li-ion
technology

brzina
0-500 min⁻¹
0-1800 min⁻¹

masa
sa baterijom
2,0 Ah
1,7 kg

obrtni moment
45 Nm

chuck
2 - 13 mm

Set sadrži:

- čekić Bušilica
- 2x 2.0 Ah Baterija
- 2.4 A punjač
- kofer
- nosač i bitovi:
- ⊖ S5, S6 x 25 mm
- ⊕ PH1, PH2 x 25 mm
- ✦ PZ1, PZ2 x 25 mm
- HSS bušilice
2-2.5-3-4-5-6 mm



izbor režima
izbor obrtni moment sile

brzo
oslobađanje
chuck head

prekidač za brzinu

smer rotacije

ergonomska gumirana ručka
za udoban i siguran hvat

LED osvetljenje

kuka za kačenje

baterija lock



FESTA
POWER X TOOLS

ČEKIĆ BUŠILICA BEŽIČNI



Br. specifikacija

28003

3

SHARE
20V

brzina
0-550 min⁻¹
0-2000 min⁻¹

masa
bez baterija
1,4 kg

obrtni moment
80 Nm

chuck
2 - 13 mm

izbor režima
izbor obrtni moment sile

brzo
oslobađanje
chuck head

prekidač za brzinu

smer rotacije

ergonomska gumirana ručka
za udoban i siguran hvat

LED osvetljenje

kuka za kačenje



Pribor

28080 Baterija 2,0 Ah
28081 Baterija 4,0 Ah

28085 Punjač 2,4 A
28086 Punjač 4,0 A



FESTA
POWER X TOOLS

ČEKIĆ BUŠILICA BEŽIČNI



*baterija nije uključena



Br. specifikacija

28004

5

SHARE
20V

Li-ion
technology

brzina
0-350 min⁻¹
0-1300 min⁻¹

masa
sa baterijom
2,0 Ah
1,3 kg

obrtni moment
28 Nm

chuck
1 - 10 mm

Set sadrži:

- čekić Bušilica
- 2x 2.0 Ah Baterija
- 2.4 A punjač
- kofer
- nosač i bitovi:
- ⊖ S5, S6 x 25 mm
- ⊕ PH1, PH2 x 25 mm
- ⊕ PZ1, PZ2 x 25 mm
- HSS bušilice
1,5-2,5-3-4-5-6 mm



izbor režima
izbor obrtni moment sile

brzo
oslobađanje
chuck head

prekidač za brzinu

prekidač
smera rotacije

ergonomska gumirana ručka
za udoban i siguran hvat

LED osvetljenje

kuka za kačenje

baterija lock



FESTA
POWER X TOOLS

BUŠILICA AKUMULATORSKI ODVIJAČ



Br. specifikacija

28005

3

SHARE
20V

brzina
0-350 min⁻¹
0-1300 min⁻¹

masa
bez baterija
0,9 kg

obrtni moment
28 Nm

chuck
1 - 10 mm

izbor režima
izbor obrtni moment sile

brzo
oslobađanje
chuck head

prekidač za brzinu

prekidač
smera rotacije

ergonomska gumirana ručka
za udoban i siguran hvat

LED osvetljenje

kuka za kačenje



Pribor

28080 Baterija 2,0 Ah

28081 Baterija 4,0 Ah

28085 Punjač 2,4 A

28086 Punjač 4,0 A



FESTA
POWER X TOOLS

BUŠILICA AKUMULATORSKI ODVIJAČ



*baterija nije uključena

Br. specifikacija

28006

5

Li-ion
technology

brzina
0-350 min⁻¹
0-1300 min⁻¹

masa
sa baterijom 1,5 Ah
1 kg

obrtni moment
20 Nm

chuck
1 - 10 mm

Set sadrži:

- čekić Bušilica
- 2x Baterija 12 V I 1.5 Ah
- punjač 12 V I 2.4 A
- kofer
- svrdla i bity:
- ⊖ S5, S6 x 25 mm
- ⊕ PH1, PH2 x 25 mm
- ⊕ PZ1, PZ2 x 25 mm
- bušilice HSS
- 1,5-2,5-3-4-5-6 mm



izbor režima
izbor obrtni moment sile

brzo oslobađanje
chuck head

prekidač za brzinu

LED osvetljenje

indikator napunjenosti
baterije

smer rotacije

ergonomska gumirana ručka
za udoban i siguran hvat

baterija



FESTA
POWER X TOOLS

BUŠILICA AKUMULATORSKI ODVIJAČ

max 20 Nm		1.0-350min ⁻¹ 0.0-1300min ⁻¹				LED		2x	Li-ion
--------------	--	---	--	--	--	-----	--	----	--------



Br. specifikacija

28007

5

Li-ion
technology

brzina
bez tereta
200 min⁻¹

masa
sa baterijom 1,5 Ah
0,4 kg

maximum obrtni
moment
3 Nm

nosač alata
1/4" heksagon

Set sadrži:

- odvijač
- punjač 5 V I 0,5 A
- bit:
- ⊖ S5 x 50 mm
- ⊕ PH1 x 50 mm
- ⊕ PH2 x 50 mm
- ⊕ H5 x 50 mm
- ⊕ T20 x 50 mm

1/4 „brzo otpuštajuća
glava sa osiguračem

podešavanja obrtni
moment

indikator punjenja baterije

zaključavanje podešavanja
položaj ručke

LED osvetljenje

prekidač smer
rotacije

ergonomske gumirane
ručka za udoban
i siguran zahvat



LED osvetljenje



FESTA
POWER X TOOLS

AKUMULATORSKI ODVIJAČ

max 3 Nm	200min ⁻¹	1/4"		LED		Li-ion	3,6 V	1,5 Ah
-------------	----------------------	------	--	-----	--	--------	-------	--------



Br. specifikacija

28008

10

SHARE
20V



1/4 „brzo otpuštajuća glava sa osiguračem



izbor smer rotacije

ergonomski gumirani ručka za udoban i siguran hvat

LED osvetljenje

kuka za kačenje

Pribor

- 28080 Baterija 2,0 Ah
- 28081 Baterija 4,0 Ah
- 28085 Punjač 2,4 A
- 28086 Punjač 4,0 A



AKUMULATORSKI UDARNI KLJUČ



*baterija nije uključena

Br. 28021 specifikacija



5

SHARE
20V



SDS stezanje glava alata



prebacivanje režima rada (sa / bez udaraljki)

prekidač za brzinu

pravac rotacije prekidač

SDS stezanje glava alata

Pribor

- 28080 Baterija 2,0 Ah
- 28081 Baterija 4,0 Ah
- 28085 Punjač 2,4 A
- 28086 Punjač 4,0 A



BEŽIČNI ČEKIĆ BUŠILICA



*baterija nije uključena

Br. 28025 specifikacija



2

SHARE
20V

- frekvencija pucanje
60-100 min⁻¹
- maksimalna dužina ekseri / spajalice
30 mm
tvrdih materijala
- maksimalna dužina ekseri / spajalice
50 mm
mekih materijala
- masa bez baterija
2,7 kg



osigurač

ergonomski gumirani ručka za udoban i siguran hvat

osigurač radni prekidač

kuka za kačenje

prekidač režima snimanja

LED signalizacija greške

LED osvetljenje

empty tray pointer

Pribor

- 28080 Baterija 2,0 Ah
- 28081 Baterija 4,0 Ah



- 28085 Punjač 2,4 A
- 28086 Punjač 4,0 A



Nails

- 23930 Zabijanje noktiju 30 mm, 2000 pcs
- 23931 Zabijanje noktiju 40 mm, 2000 pcs
- 23932 Zabijanje noktiju 50 mm, 2000 pcs

Kopča

- 23935 Klip za nokte 30 mm, 2000 pcs
- 23936 Klip za nokte 40 mm, 2000 pcs



Odgovarajuće vrste eksera i spajalica::

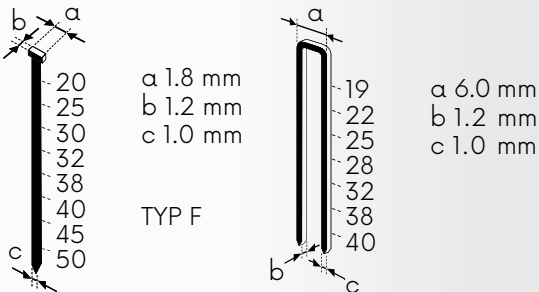

pokretni poklopac časopisa

brava poklopca časopisa



AKUMULATORSKI ZABIJAČ I HEFTALICA

max 60 min⁻¹ | a 1.8 mm, b 1.2 mm, c 1.0 mm | TYPE F | a 6.0 mm, b 1.2 mm, c 1.0 mm | LED | 2,7 KG

*baterija nije uključena

Br. 28070 specifikacija



SHARE
20V

temperatura boje
6000 K

masa
bez baterija
1,6 kg

LED napajanje
30W

svetlosni fluks
1800 lm (100%)
1000 lm (60%)
500 lm (30%)



podešavanje glave za 360°

prirubnica za montažu

podešavanje intenziteta svetlosti
30%, 60%, 100%

Pribor

28080 Baterija 2,0 Ah

28081 Baterija 4,0 Ah

28085 Punjač 2,4 A

28086 Punjač 4,0 A



LED SVETLO AKU



*baterija nije uključena

Br. specifikacija

28065



BRUSHLESS SHARE
20V

brzina bez tereta
8500 min⁻¹

maksimalna debljina rezani materijal
15 mm

masa bez baterija
1,6 kg

maksimalan prečnik točka
125 mm

otvori motora

ergonomska gumirana ručka za udoban i siguran hvat

zaključavanje rotacije

osigurač radni prekidač

brzo oslobađanje mehanizam zaštitni poklopac



matice za stezanje točkova



Pribor

28080 Baterija 2,0 Ah

28081 Baterija 4,0 Ah

28085 Punjač 2,4 A

28086 Punjač 4,0 A



AKUMULATORSKA UGAONA BRUSILICA



*baterija i disk nisu uključeni

Br. 28030
specifikacija



4

SHARE
20V

brzina bez tereta
8000 min⁻¹

maksimalna debljina rezani materijal
15 mm

masa bez baterija
1,6 kg

maksimalan prečnik točka
125 mm

ergonomska gumirana ručka za udoban i siguran hvat

zaključavanje rotacije

osigurač radni prekidač

brzo oslobađanje mehanizam zaštitni poklopac

matice za stezanje točkova



Pribor

28080 Baterija 2,0 Ah

28081 Baterija 4,0 Ah

28085 Punjač 2,4 A

28086 Punjač 4,0 A



AKUMULATORSKA UGAONA BRUSILICA



*baterija i disk nisu uključeni

Br. 28032
specifikacija



4

SHARE
20V

brzina bez tereta
10000 min⁻¹

masa bez baterija
1 kg

ekscentričnost točkovi
5 mm

prečnika točkovi
125 mm



Pribor

- 28080 Baterija 2,0 Ah
- 28081 Baterija 4,0 Ah
- 28085 Punjač 2,4 A
- 28086 Punjač 4,0 A



BATERIJA ORBITAL SANDER



*baterija nije uključena

Br. specifikacija
28040



SHARE
20V

broj oscilacije bez opterećenja
5000-15000 min⁻¹

masa bez baterija
1 kg

kontrola brzine



Pribor

- 28080 Baterija 2,0 Ah
- 28081 Baterija 4,0 Ah
- 28085 Punjač 2,4 A
- 28086 Punjač 4,0 A



VIŠENAMENSKI BEŽIČNI UREĐAJ



*baterija nije uključena

Br. specifikacija
28045



SHARE
20V



Pribor

28080 Baterija 2,0 Ah

28081 Baterija 4,0 Ah

28085 Punjač 2,4 A

28086 Punjač 4,0 A



FESTA
POWER X TOOLS

AKUMULATORSKA KRUŽNA TESTERA

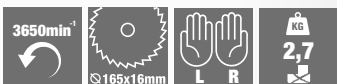

* baterija nije uključena

Br. 28035 specifikacija list testere je deo paketa ø165x16 mm 24T



SHARE
20V

ergonomska gumirana ručka
za udoban i siguran hvat

broj udaraca
sečiva

0-2400 min⁻¹

masa
bez baterija
1,8 kg

mak. ugao
bevel cut
45 stepeni

mak. rezati
profil
čelik: 6 mm
drvo: 80 mm

osigurač
radni prekidač

predoscilacija
podešavanje

LED

pav
zaključavanje
nagiba

Pribor

28080 Baterija 2,0 Ah
28081 Baterija 4,0 Ah

28085 Punjač 2,4 A
28086 Punjač 4,0 A



zaključavanje
šipke

baza

vodica



AKUMULATORSKA UBODNA TESTERA



*baterija nije uključena

Br. specifikacija

28050



4



zakošeni rez

0°
45° 45°

SHARE
20V

broj
oscilacije bez
opterećenja

0-3000 min⁻¹

masa
bez baterija
1,7 kg

mak. debljina rezanja
Drvo: 100 mm
Čelik: 5 mm
aluminijum/
bakar: 20 mm

osigurač
radni prekidač

Pribor

28080 Baterija 2,0 Ah
28081 Baterija 4,0 Ah

28085 Punjač 2,4 A
28086 Punjač 4,0 A



ergonomska gumirana ručka
za udoban i siguran hvat



AKUMULATORSKA KLIPNA TESTERA



*baterija nije uključena

Br. specifikacija

28055



4

brzo
oslobađanje
testere



SHARE
20VLi-ion
technology28004
strana 628032
strana 1228055
strana 15SNIŽENA
CENA
+ BESPLATNA TORBA28035
strana 14

37330

28040
strana 13FESTA
POWER X TOOLS

AKUMULATORSKI SET SA KOMPLETOM TORBA 5+3

- 28004 - Akumulatorska bušilica sa čekićem FESTA SHARE20V
 28032 - Ugaona brusilica Akumulatorska FESTA SHARE20V 115 mm
 28035 - Kružna testera Akumulatorska FESTA SHARE20V 165 mm/d 16 mm
 28040 - Ekscentrična brusilica Akumulatorska FESTA SHARE20V 125 mm 8 otv.
 28055 - Hack testera Akumulatorska FESTA SHARE20V
 28080 - Baterija za akumulatorske alate FESTA SHARE20V 2,0 Ah
 28081 - Baterija za akumulatorske alate FESTA SHARE20V 4,0 Ah
 28086 - Punjač FESTA SHARE20V 4,0 A

28080
strana 1828081
strana 1828086
strana 18

Br. specifikacija

28101



1

SHARE
20VLi-ion
technology

BRUSHLESS

28002
strana 528030
strana 12SNIŽENA
CENA
+ BESPLATNA TORBA28040
strana 13

BRUSHLESS

28055
strana 15

37330

28035
strana 14FESTA
POWER X TOOLS

AKUMULATORSKI SET SA KOMPLETOM TORBA 5+3

- 28002 - Akumulatorska bušilica sa čekićem FESTA SHARE20V
 28030 - Ugaona brusilica Akumulatorska FESTA „BRUSHLESS“ SHARE20V 125 mm
 28035 - Kružna testera Akumulatorska FESTA SHARE20V 165 mm/d 16 mm
 28040 - Ekscentrična brusilica Akumulatorska FESTA SHARE20V 125 mm 8 otv.
 28055 - Hack testera Akumulatorska FESTA SHARE20V
 28080 - Baterija za akumulatorske alate FESTA SHARE20V 2,0 Ah
 28081 - Baterija za akumulatorske alate FESTA SHARE20V 4,0 Ah
 28086 - Punjač FESTA SHARE20V 4,0 A

28080
strana 1828081
strana 1828086
strana 18

Br. specifikacija

28104



1

SHARE
20V *Li-ion*
technology

28004
strana 6



28030
strana 12



BRUSHLESS

28025
strana 9



37330



SNIŽENA
CENA
+BESPLATNA TORBA

FESTA
POWER X TOOLS

AKUMULATORSKI SET SA KOMPLETOM TORBA 3+3

- 28004 - Akumulatorska bušilica sa čekićem FESTA SHARE20V
- 28025 - Čekić za bušenje Akumulatorski FESTA SDS+ SHARE20V
- 28030 - Ugaona brusilica Akumulatorska FESTA „BRUSHLESS“ SHARE20V 125 mm
- 28080 - Baterija za akumulatorske alate FESTA SHARE20V 2,0 Ah
- 28081 - Baterija za akumulatorske alate FESTA SHARE20V 4,0 Ah
- 28086 - Punjač FESTA SHARE20V 4,0 A

28080
strana 18



28081
strana 18



28086
strana 18



Br. specifikacija

28102



1

BRUSHLESS **SHARE**
20V *Li-ion*
technology

28030
strana 12



37330



28002
strana 5



SNIŽENA
CENA
+BESPLATNA TORBA

FESTA
POWER X TOOLS

AKUMULATORSKI SET SA KOMPLETOM TORBA 2+3

- 28002 - Akumulatorska bušilica sa čekićem FESTA SHARE20V
- 28030 - Ugaona brusilica Akumulatorska FESTA „BRUSHLESS“ SHARE20V 125 mm
- 28080 - Baterija za akumulatorske alate FESTA SHARE20V 2,0 Ah
- 28081 - Baterija za akumulatorske alate FESTA SHARE20V 4,0 Ah
- 28086 - Punjač FESTA SHARE20V 4,0 A

28080
strana 18



28081
strana 18



28086
strana 18



Br. specifikacija

28103



1

SHARE 20V



2,0 Ah



4,0 Ah

FESTA
POWER X TOOLS

PUNJAČ 20 V I 24 A

Br.	specifikacija
28085	220 – 240 V, 50 – 60 Hz, 70 W



20

SHARE 20V



2,0 Ah



4,0 Ah

FESTA
POWER X TOOLS

PUNJAČ 20 V I 4,0 A

Br.	specifikacija
28086	*220 – 240 V, 50 – 60 Hz, 105 W



20

SHARE 20V *Li-ion* technology



indikator punjenja baterije

FESTA
POWER X TOOLS

BATERIJA 20 V I 2,0 Ah

20V	2,0 Ah	Li-ion	KG 0,4
-----	-----------	--------	-----------

Br.	specifikacija
28080	



20

SHARE 20V *Li-ion* technology



indikator punjenja baterije

FESTA
POWER X TOOLS

BATERIJA 20 V I 4,0 Ah

20V	4,0 Ah	Li-ion	KG 0,7
-----	-----------	--------	-----------

Br.	specifikacija
28081	



20

BRUSHLESS

alat se napaja
DC motor bez četkica

obrotni moment	
brzina	
pravac koji se bira rotacije	
chuck	
bušenje, bušenje sa čekićem, šrafljenje	
broj udaraca u minuti	
bušenje, uvrtnje šrafova	
masa sa / bez baterije	
način vezivanja	
način vezivanja	
način vezivanja	
ekscentricitet diska	
upravljanje uređajem za desnu i levu ruku	
ispunjava taj standard	
svetlosni fluks	
usmereni ugao svetlosti	
maksimalna frekvencija paljenja	

**SHARE
20V**

alat je kompatibilan
sa obe Baterije

	pogodne vrste noktiju
	pogodne vrste kopči
	točak za brušenje sa rupama
	maksimalni prečnik točka
	prečnik točka
	maksimalna debljina sečenja materijal: drvo
	maksimalna debljina sečenja materijal: čelik
	podešavanje predoscilovanja
	dodatak za testere
	broj udaraca sečiva
	moćnost zakošenog rezati
	brzo otpuštanje lista testere
	broj oscilacija testere
	LED osvetljenje
	kapacitet baterije
	baterija
	vreme punjenja baterija

TEHNIČKI
SPECIFIKACIJE

KATALOŠKI BROJ PROIZVODA	28000	28001	28002	28003	28004
Ime	Čekić Bušilica bežični	Čekić Bušilica bežični	Čekić Bušilica bežični	Čekić Bušilica bežični	Čekić Bušilica bežični
Brzina bez tereta	I.0-550 min ⁻¹ II.0-2000 min ⁻¹	I.0-550 min ⁻¹ II.0-2000 min ⁻¹	I.0-550 min ⁻¹ II.0-2000 min ⁻¹	I.0-500 min ⁻¹ II.0-1800 min ⁻¹	I.0-500 min ⁻¹ II.0-1800 min ⁻¹
Broj pogodaka	I.0-8800min ⁻¹ II.0-32000min ⁻¹	I.0-8800min ⁻¹ II.0-32000min ⁻¹	I.0-8800min ⁻¹ II.0-32000min ⁻¹	0-19200 min ⁻¹	0-19200 min ⁻¹
Broj udaraca					
Obrtni trenutak	80 Nm	80 Nm	80 Nm	45 Nm	45 Nm
Maks. baterija napon	20V	20V	20V	20V	20V
Broj faza obrtnog momenta	20+1+1	20+1+1	20+1+1	19+1+1	19+1+1
Stezna glava	2-13 mm	2-13 mm	2-13 mm	2-13 mm	2-13 mm
Težina bez baterija	1,4kg	1,4kg	1,4kg	1,3kg	1,3kg
Cover	IPX0	IPX0	IPX0	IPX0	IPX0
Nivo zvučnog pritiska neizvesnost K	LpA=97,04dB(A) K=5dB(A)	LpA=97,04dB(A) K=5dB(A)	LpA=97,04dB(A) K=5dB(A)	LpA=79dB(A) K=5dB(A)	LpA=79dB(A) K=5dB(A)
Nivo snage zvuka neizvesnost K	LwA=86,04dB(A) K=5dB(A)	LwA=86,04dB(A) K=5dB(A)	LwA=86,04dB(A) K=5dB(A)	LwA=90dB(A) K=5dB(A)	LwA=90dB(A) K=5dB(A)
Vibracije bez udaranja u metal	$a_{h,D}=3,9m/s^2$ K=1,5m/s ²	$a_{h,D}=3,9m/s^2$ K=1,5m/s ²	$a_{h,D}=3,9m/s^2$ K=1,5m/s ²	$a_{h,D}=2,4m/s^2$ K=1,5m/s ²	$a_{h,D}=2,4m/s^2$ K=1,5m/s ²
Vibracije bez udaranja u beton	$a_{h,D}=11,4m/s^2$ K=1,5m/s ²	$a_{h,D}=11,4m/s^2$ K=1,5m/s ²	$a_{h,D}=11,4m/s^2$ K=1,5m/s ²	$a_{h,D}=7,5m/s^2$ K=1,5m/s ²	$a_{h,D}=7,5m/s^2$ K=1,5m/s ²
Maksimalna vibracija, nesigurnost K					
Udarna snaga					
Prečnik bušenja					
Vibracije u beton -glavna ručka					
Vibracije u betonu - dodatna ručka					
Sadržaj paketa	bušilica, 2.4 punjač, baterija 2.0 Ah, 4.0 Ah baterija, dodatna ručka, kofer	bušilica, punjač 2.4 A, baterija 2.0 Ah, dodatna ručka, kofer	bušiti	bušilica, 2.4 punjač, 2x 2.0 Ah baterija, 6x bit, nosač, 6x bušilica, kofer	bušiti



28005	28006	28007	28008	28021	28025
Bušilica akumulatorski odvijač	Bušilica akumulatorski odvijač	Bušilica akumulatorski od- vijač	Akumulatorski odvijač	Akumulatorski udarni ključ	Akumulatorski čekić Bušilica
1.0-350 min ⁻¹ 11.0-1300 min ⁻¹	1.0-350 min ⁻¹ 11.0-1300 min ⁻¹	1.0-350 min ⁻¹ 11.0-1300 min ⁻¹	200 min ⁻¹	0-2000 min ⁻¹	1.0-300 min ⁻¹ 11.0-1000 min ⁻¹
					0-5000bpm
				0-3000bpm	
28 Nm	28 Nm	20 Nm	3 Nm	150 Nm	
20V	20V	12V	3.6V	20V	20V
19+1	19+1	19+1	6+1		
1-10mm	1-10mm	1-10mm	1/4" heksagon	1/4" heksagon	SDS+
0,9kg	0,9kg	*1kg	*0,4kg	1,2kg	1,7kg
IPX0	IPX0	IPX0	IPX0	IPX0	IPX0
LpA=69dB(A) K=5dB(A)	LpA=69dB(A) K=5dB(A)	LpA=78dB(A) K=5dB(A)	LpA=58dB(A) K=3dB(A)	LpA=92dB(A) K=3dB(A)	LpA=82,98dB(A) K=3dB(A)
LwA=80dB(A) K=5dB(A)	LwA=80dB(A) K=5dB(A)	LwA=67dB(A) K=5dB(A)	LwA=69dB(A) K=3dB(A)	LwA=103dB(A) K=3dB(A)	LwA=93,98dB(A) K=3dB(A)
$\alpha_{h,D} < 1,9m/s^2$ K=1,5m/s ²	$\alpha_{h,D} < 1,9m/s^2$ K=1,5m/s ²	$\alpha_{h,D} = 2,1m/s^2$ K=1,5m/s ²			
$\alpha_{h,D} = 10,1m/s^2$ K=1,5m/s ²	$\alpha_{h,D} = 10,1m/s^2$ K=1,5m/s ²	$\alpha_{h,D} = 7,5m/s^2$ K=1,5m/s ²			
			$\alpha_h < 2,5m/s^2$ K=1,5m/s ²	$\alpha_{h,D} = 15,9m/s^2$ K=1,5m/s ²	
					1,2J
					Čelik: 10mm concrete: 20mm Drvo: 20mm
					$\alpha_{h,(HD)} = 5,582m/s^2$ K=1,5m/s ²
					$\alpha_{h,(HD)} = 5,523m/s^2$ K=1,5m/s ²
bušilica, 2,4 punjač, 2x 2.0 Ah baterija, 6x bit, nosač, 6x bušilica, kofer	bušiti	bušilica, 2,4 punjač, 2x 1.5 Ah baterija, 6x bit, nosač, 6x bušilica, kofer	šrafciğer, punjač 0,5 A, 1,5 Ah baterija, 5x bit	zatezač	čekić za bušenje, dodatna ručka, SDS stezanje glava alata

* težina je navedena uključujući bateriju

TEHNIČKI
SPECIFIKACIJE

KATALOŠKI BROJ PROIZVODA	28030	28032	28035	28040
Ime	Bežični ugao brusilica	Bežični ugao brusilica	Bežični kružni Testera	Baterija orbital sander
Brzina praznog hoda	8500 min ⁻¹	8000 min ⁻¹	3650 min ⁻¹	10.000 min ⁻¹
Broj oscilacija bez opterećenja				
Napred				
Broj stepeni predoscilovanja				
Broj listova lista testere				
Maksimalni profil sečenja				
Maksimalni prečnik točka	125 mm	115 mm		
Disk za podršku				125 mm
8 usisnih rupa na krugu				65 mm
Ekscentricitet točka				5 mm
Veličina navoja vretena	M14	M14		
Maksimalna debljina rezanog materijala	15 mm	15 mm		
Maks. baterija napon	20V	20V	20V	20V
Podesiv ugao sečenja			0-45°	
Isecite pod uglom od 45 °			35 mm	
Isecite pod uglom od 90 °			50 mm	
Ugao oscilacije				
Dimenzija baza za mlevenje delta				
Kontrola brzine vibracija				
Pričvršćivanje lista testere				
Hod lista testere				
Baza tanjira veličine			28 cm x 13,3 cm	
Težina bez baterija	1,6kg	1,6kg	2,7kg	1kg
Prečnik točka			165 mm	
Debljina tela točka			1,4 mm ± 5% mm	
Debljina SK sečiva			2,0 ± 5% mm	
Širina sečenja			2,3 ± 5% mm	
Prečnik otvora točka nakon stezanja			16 mm	
Broj zubaca diska			24	
Cover	IPX0	IPX0	IPX0	IPX0
Tip eksera, visina k širina k debljina				
Kopčas-raspon k visina k širina k debljina				
Maks. dužina eksera / klipova u meke prostirke.				
Maks. dužina eksera / klipova u tvrdi mat.				
Prosek / maks. frekvencija snimanja				
Vreme rada (4 AH baterija, potpuno napunjena)				
Kapacitet magazina za eksere / spajalice				
Nivo zvučnog pritiska neizvesnost K	LpA=87,1dB(A) K=3dB(A)	LpA=76,67dB(A) K=3dB(A)	LpA=84dB(A) K=3dB(A)	LpA=76dB(A) K=3dB(A)
Nivo snage zvuka neizvesnost K	LwA=98,1dB(A) K=3dB(A)	LwA=87,67dB(A) K=3dB(A)	LwA=95dB(A) K=3dB(A)	LwA=87dB(A) K=3dB(A)
Vibracije prilikom brušenja površine	$\alpha_{h,AG}=8,363m/s^2$ K=1,5m/s ²	$\alpha_{h,AG}=5,324m/s^2$ K=1,5m/s ²		
Vibracija za sečenje ploče				
Vibracija za sečenje lima				
Vibracija za sečenje Drvo:en ramova				
Maksimalna vibracija, nesigurnost K			$\alpha_h < 2,5m/s^2$ K=1,5m/s ²	$\alpha_h = 9,5m/s^2$ K=1,5m/s ²
Sadržaj paketa	brusilica, poklopac točka, dodatna ručka, ključ	brusilica, poklopac točka, dodatna ručka, ključ	Testera, graničnik dubine, testere	mlin, vreća za sakupljanje prašine

28045	28050	28055	28070
Bežični uređaj multifunkcionalni	Akumulatorska ubodna testera	Akumulatorska klipna testera	Akumulatorski zabijač i heftalica
5000-15000 min ⁻¹		0-3000 min ⁻¹	
	3+0	1°	
	0-2400 min ⁻¹		
	Čelik: 6mm, Drvo: 80mm	Drvo: 100 mm, Čelik: 5 mm, aluminijum / bakar: 20 mm	
20V		20V	20V
	ukošeni rez mak. 45 °		
3°			
90 mm			
Da			
univerzalan		univerzalan	
		20 mm	
1kg	1,8kg	1,7kg	2,7kg
IPX0	IPX0	IPX0	IPX0
			F, 20-50mm x 1,2mm x 1,0 mm
			6,0mm x 19-40mm x 1,2mm x 1,0mm
			50 mm
			30 mm
			60/100 min ⁻¹
			1 sat
			100 komada
LpA=78dB(A) K=3dB(A)	LpA=88,1dB(A) K=5dB(A)	LpA=87,33dB(A) K=5dB(A)	LpA=79,9dB(A) K=3dB(A)
LwA=89dB(A) K=3dB(A)	LwA=99,1dB(A) K=5dB(A)	LwA=98,33dB(A) K=5dB(A)	LwA=90,9dB(A) K=3dB(A)
	$\alpha_{h,B}=3,3m/s^2$ $K=1,5m/s^2$ $\alpha_{h,M}=4m/s^2$ $K=1,5m/s^2$	$\alpha_{h,B}=21,10m/s^2$ $K=1,5m/s^2$	
		$\alpha_{h,WB}=21,98m/s^2$ $K=1,5m/s^2$	
$\alpha_h=2,8m/s^2$ $K=1,5m/s^2$			$\alpha_h=1,39m/s^2$ $K=1,5m/s^2$
brusilica, prilozi (testera, strugač, nosač), 3x brusni papir P80	pila, Führungsschiene, usisni dodatak, 2x list testere	testera, 2x list testere	heftalica / heftalica, 200x ekseri, 200x spajalice



MERNI INSTRUMENTI

24 - 57



26

MERNE TRAKE I FIBERGLAS
TRAKE KOMELON

28

MERNE TRAKE FESTA



31

MERNE TRAKE



32

METAR DRVENI



34

POMIČNA MERILA



35

RAVNALA I UGLOMERI



38

MERNI ALATI HORIZONT



43

LIBELE NIVELA



45

DIGITALNA MERILA



46

LASERSKI MERAČI



50

OLOVKE I MARKERI



56

SPREJEVI



· MERILA VRHUNSKOG KVALITETA I TOČNOSTI

KOMELON®

- II. klasa tačnosti prema EEC 755345
- Najlonski površinski sloj DURA NY Coat™

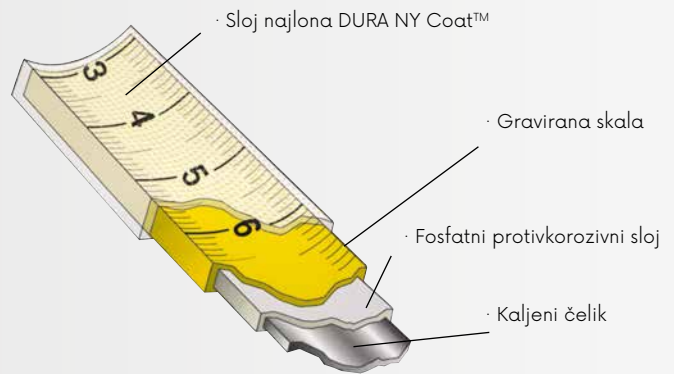

KOMELON® METAR

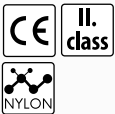

· Sloj najlona DURA NY Coat™



Br.	Specifikacija	
10002	2 m · 16 mm	10
10003	3 m · 16 mm	10
10005	5 m · 19 mm	10
10008	8 m · 25 mm	10

KOMELON® METAR

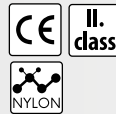

· Sloj najlona DURA NY Coat™



Br.	Specifikacija	
10025	5 m · 25 mm	10

KOMELON® METAR

- Automatska kočnica
- Gumirani

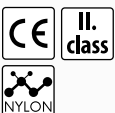

· Sloj najlona DURA NY Coat™



Br.	Specifikacija	
10033	3 m · 16 mm	6
10035	5 m · 19 mm	6

KOMELON® METAR



Br.	Specifikacija	
10043	3 m · 16 mm	30
10045	5 m · 19 mm	30
10048	8 m · 25 mm	12

KOMELON®
PANTLJKA
ČELIČNA



Br.	Specifikacija	
10110	10 m · 10 mm	6
10120	20 m · 10 mm	6
10130	30 m · 10 mm	6



KOMELON®
PANTLJKA
PLATNENA



Br.	Specifikacija	
10330	10 m · 13 mm	6
10332	20 m · 13 mm	6
10334	30 m · 13 mm	6
10336	50 m · 13 mm	6



KOMELON®
PANTLJKA
PLATNENA



Br.	Specifikacija	
10430	30 m · 13 mm	1
10450	50 m · 13 mm	1
10490	100 m · 13 mm	1



KOMELON®
STALAK ZA METRE

· Ispunjen sa stavkama 10996

- 10003 · 5 kom
- 10005 · 4 kom
- 10008 · 1 kom
- 10033 · 2 kom
- 10035 · 3 kom
- 10045 · 2 kom
- 10025 · 3 kom
- 10110 · 1 kom
- 10120 · 1 kom
- 10130 · 1 kom
- 10430 · 1 kom
- 10330 · 1 kom
- 10332 · 1 kom
- 10334 · 1 kom
- 10336 · 1 kom



· Ilustraciona fotografija

Br.	Specifikacija	
10999	Stalak za metre	1
10996	Stalak za metre ispunjen	1



· Information about the tape



- A** · length of tape
- B** · accuracy class
- C** · declaration of conformity - CE
- D** · year of manufacture
- E** · the number of the accredited certification office issuing the certificate
- F** · producer
- G** · special tape adjustment
- H** · the temperature at which the test was performed

STALAK ZA METRE KOMELON

Br.	Specifikacija	
10998		1



· Ilustraciona fotografija



FESTA

FESTA

METAR

- Skala sa velikim brojevima
- Gumirani
- Sloj najlona



Br.	Specifikacija	
11353	3 m · 19 mm	12
11355	5 m · 19 mm	12
11356	5 m · 25 mm	12
11358	8 m · 25 mm	6
11360	10 m · 25 mm	6



FESTA

METAR



Br.	Specifikacija	
11343	3 m · 16 mm	6
11345	5 m · 19 mm	6
11347	7,5 m · 25 mm	6



FESTA

METAR

- 3 x kočnica
- Magnetni završetak
- Kočenje
- Gumirani



Br.	Specifikacija	
11323	3 m · 16 mm	10
11325	5 m · 19 mm	10
11327	7,5 m · 25 mm	6



FESTA

METAR

- Kompaktna veličina
- Sloj najlona



Br.	Specifikacija	
11220	3 m · 16 mm	12
11221	5 m · 19 mm	12



FESTA

METAR

- Skala sa velikim brojevima



Br.	Specifikacija	
11226	2 m · 16 mm	10
11239	3 m · 19 mm	10
11259	5 m · 19 mm	10
11260	7,5 m · 25 mm	10

FESTA

METAR

- Magnetni završetak
- Gumirani
- Fluorescentna traka
- Skala sa velikim brojevima



Br.	Specifikacija	
11102	2 m · 16 mm	10
11103	3 m · 16 mm	10
11105	5 m · 19 mm	12
11106	5 m · 25 mm	12
11107	7,5 m · 25 mm	10
11110	10 m · 25 mm	6



FESTA

METAR

- Automatska kočnica
- Gumirani



Br.	Specifikacija	
11333	3 m · 16 mm	12
11335	5 m · 19 mm	12
11337	7,5 m · 25 mm	12
11338	10 m · 25 mm	12



Johnney

METAR

- Matna površina trake



Br.	Specifikacija	
11002	2 m · 13 mm	12
11003	3 m · 13 mm	12
11005	5 m · 13 mm	12
11006	5 m · 19 mm	12
11007	7,5 m · 19 mm	12
11008	10 m · 25 mm	12



METAR

- Kočenje
- Gumirani

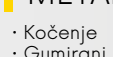

Br.	Specifikacija	
11082	2 m · 16 mm	12
11083	3 m · 16 mm	12
11085	5 m · 19 mm	12



METAR

- cm / inch
- Gumirani



Br.	Specifikacija	
11416	5 m · 19 mm	10

METAR

- Kočenje



Br.	Specifikacija	
11200	2 m · 13 mm	24
11201	2 m · 16 mm	24
11202	2 m · 19 mm	24
11204	3 m · 13 mm	24
11205	3 m · 16 mm	24
11206	3 m · 19 mm	24
11207	5 m · 19 mm	12
11208	5 m · 25 mm	12
11209	7,5 m · 25 mm	12
11210	10 m · 25 mm	12



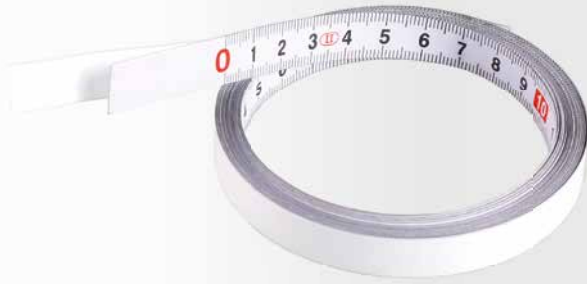

SAMOLEPLJIVA MERNA TRAKA

II. class



Br.	Specifikacija	
11311	1 m · 12,5 mm	30
11312	2 m · 12,5 mm	30
11313	3 m · 16 mm	30
11314	5 m · 19 mm	30

METAR SA IMENOM, 3M · 16 MM

CE II. class



Br.	Ime	Br.	Ime	Br.	Ime
13500	JIRÍ	13512	MICHAL	13524	ROMAN
13501	PETR	13513	MILAN	13525	ŠIKULA
13502	JOSEF	13514	KAREL	13526	RADEK
13503	TOMÁŠ	13515	VLADIMÍR	13527	MISTR
13504	JAN	13516	DĚDEČEK	13528	ONDŘEJ
13505	MARTIN	13517	MŮJ METR	13529	MAREK
13506	JAROSLAV	13518	VÁCLAV	13530	STANISLAV
13507	FRANTIŠEK	13519	JAKUB	13531	BOREC
13508	PAVEL	13520	LUKÁŠ	13532	TATÍNEK
13509	MIROSLAV	13521	2X MĚŘ	13533	ANTONÍN
13510	BIG BOSS	13522	LADISLAV	13534	ALEŠ
13511	ZDENĚK	13523	DAVID		



FESTA

METAR PRIVEZAK

- Metar sa velikim ciframa
- Svojstva klasične merne trake

II. class

MOQ 12

Br.	Specifikacija	
11410	2 m · 16 mm 6 boja	12

METAR PRIVEZAK

Br.	Specifikacija	
11420	1 m · 6 mm narandžasta	24



METAR PRIVEZAK

Br.	Specifikacija	
11444	1 m · 6 mm Beli	20

METAR PRIVEZAK

Br.	Specifikacija	
11425	1 m · 6 mm	25

LIBELA PRIVEZAK

Br.	Specifikacija	
11445		100



FESTA

PANTLJIKA ČELIČNA

· Oko



Br.	Specifikacija	
12010	10 m · 10 mm	1
12020	20 m · 10 mm	1
12030	30 m · 10 mm	1
12050	50 m · 10 mm	6



FESTA

PANTLJIKA OD FIBER-STAKLA

· Oko



Br.	Specifikacija	
12110	10 m · 13 mm	6
12120	20 m · 13 mm	1
12130	30 m · 13 mm	1
12150	50 m · 13 mm	1



FESTA

PANTLJIKA ČELIČNA

· Oko + kukica

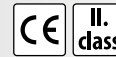

Br.	Specifikacija	
12210	10 m · 10 mm	6
12220	20 m · 10 mm	6
12230	30 m · 10 mm	6
12250	50 m · 10 mm	6



FESTA

PANTLJIKA ČELIČNA NA VILJUŠCI

· Oko



Br.	Specifikacija	
12433	30 m · 12,5 mm	20
12435	50 m · 12,5 mm	10



MERNI TOČAK

- resistant, light and compact
- counter attribute when moving forward and subtract when moving back
- built-in lighting - 2 x AAA batteries in handle
- Kesa



Br.	Specifikacija	
15989	max. 10 km	2



FESTA

TELESKOPSKA MERNA ŠIPKA

· Kesa

Br.	Specifikacija	
15983	0,7 - 3 m	10
15985	1,1 - 5 m	10
15988	1,6 - 8 m	5

METAR DRVENI PREKLAPAJUĆI

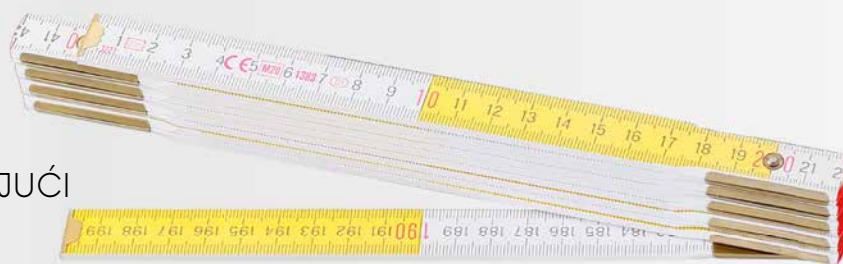

Br.	Specifikacija	
13010	1 m · Beli	20
13020	2 m · Beli	10
13021	1 m · žuti	20
13022	2 m · žuti	10
13023	2 m · Belo - žuti	10

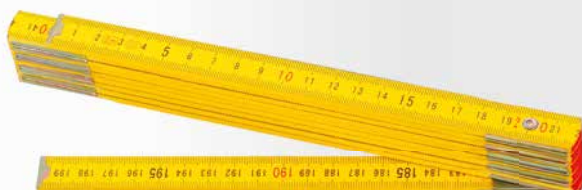

METAR DRVENI PREKLAPAJUĆI



Br.	Specifikacija	
13111	1 m · žuti	10
13120	2 m · žuti	5

METAR PLASTIČNI PREKLAPAJUĆI



Br.	Specifikacija	
13210	1 m · mini	10
13211	1 m	1
13220	2 m	1



METAR DRVENI SA IMENOM



Br.	Ime	Br.	Ime	Br.	Ime
13401	JIŘÍ	13426	DANIEL	13451	JANA
13402	JAN	13427	ANTONÍN	13452	EVA
13403	PETR	13428	VOJTĚCH	13453	PETRA
13404	JOSEF	13429	FILIP	13454	MAJKA
13405	PAVEL	13430	ADAM	13455	HANA
13406	MARTIN	13431	MILOSLAV	13456	ANNA
13407	JAROSLAV	13432	MATĚJ	13457	LENKA
13408	TOMÁŠ	13433	ALEŠ	13458	KATKA
13409	MIROSLAV	13434	JAROMÍR	13459	LUCIE
13410	ZDENĚK	13435	LIBOR	13460	ALENA
13411	FRANTIŠEK	13436	DOMINIK	13461	VERONIKA
13412	VÁCLAV	13437	PATRIK	13462	MARTINA
13413	MICHAL	13438	VLASTIMIL	13463	JITKA
13414	MILAN	13439	JINDŘICH	13464	BIG BOSS
13415	KAREL	13440	MILOŠ	13465	2 x MĚŘ
13416	JAKUB	13441	JÁN	13466	TATÍNEK
13417	DAVID	13442	PETER	13467	DĚDEČEK
13418	LUKÁŠ	13443	ONDREJ	13468	ŠIKULA
13419	VLADIMÍR	13444	JOZEF	13469	MISTR
13420	LADISLAV	13445	PAVOL	13470	MACHR
13421	ONDŘEJ	13446	L'UBOMÍR	13471	BOREC
13422	ROMAN	13447	KAROL	13472	UŽ JE MŮJ
13423	STANISLAV	13448	RADOSLAV	13473	MŮJ METR
13424	MAREK	13449	VOJTĚCH		
13425	RADEK	13450	ZDENKO		

STALAK ZA METRE

· Ispunjen sa stakama 13399

- 13401 · 15 kom
- 13402 · 15 kom
- 13403 · 15 kom
- 13404 · 15 kom
- 13405 · 15 kom
- 13406 · 15 kom
- 13412 · 15 kom
- 13413 · 15 kom
- 13414 · 15 kom
- 13415 · 15 kom
- 13416 · 15 kom
- 13417 · 15 kom
- 13418 · 15 kom
- 13419 · 15 kom
- 13420 · 15 kom
- 13421 · 10 kom
- 13422 · 10 kom
- 13423 · 10 kom
- 13424 · 10 kom
- 13425 · 10 kom
- 13426 · 10 kom
- 13427 · 10 kom
- 13428 · 10 kom
- 13429 · 10 kom
- 13430 · 10 kom
- 13431 · 10 kom
- 13432 · 10 kom
- 13433 · 10 kom
- 13434 · 10 kom
- 13435 · 10 kom
- 13436 · 10 kom
- 13437 · 10 kom
- 13438 · 10 kom
- 13439 · 10 kom
- 13440 · 10 kom



Br.	Specifikacija	
13399	Stalak za metre ispunjen	1
13400	Stalak za metre	1

FESTA

LENJIR ALU

ALU



· 2 x libele

Br.	Specifikacija	
14030	600 mm	6

FESTA

LENJIR ALU

ALU



Br.	Specifikacija	
14015	400 mm	48
14017	600 mm	50
14019	1000 mm	40

FESTA

LENJIR METALNI INOX

INOX

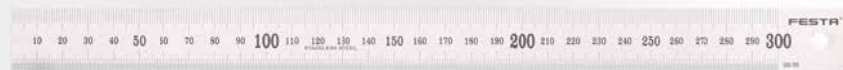

Br.	Specifikacija	
14010	300 mm	10
14011	600 mm	20
14012	1000 mm	20

**FESTA**

ŠUBLER DIGITALNI

INOX



Br.	Specifikacija	
14007	150 0,01 mm	10
14008	200 0,01 mm	10
14009	300 0,01 mm	10



ŠUBLER DIGITALNI

· Tačnost 0,2 mm, resolution 0,1 mm

Br.	Specifikacija	
14013	150 0,2 mm	10

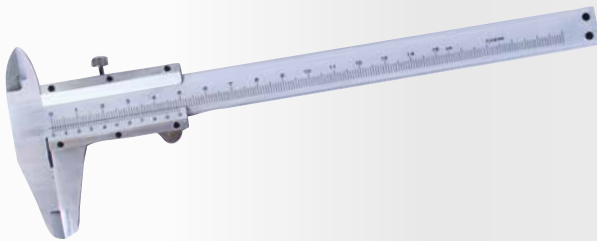
**FESTA**

ŠUBLER

INOX

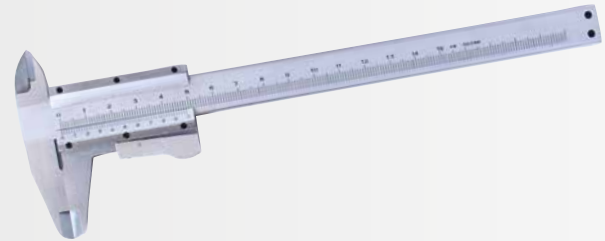

Br.	Specifikacija	
14001	150 0,02 mm	10
14002	200 0,02 mm	10
14003	300 0,02 mm	10

**FESTA**

ŠUBLER

INOX



Br.	Specifikacija	
14004	150 0,02 mm	10

**FESTA**

MIKROMETAR



Br.	Specifikacija	
14040	0 - 0,25 0,01 mm	10
14045	25 - 50 0,01 mm	10



ŠUBLER

HOBBY



Br.	Specifikacija	
14006	150 mm	50

**FESTA**

MEROLO ODSUPANJA

INOX



Br.	Specifikacija	
14035	0 - 10mm 0,01 mm	10



MERNI LISTIĆI

· 20 listića

Br.	Specifikacija	
14080	0,05 - 1 mm	10



FESTA

UGLOMER SA POMOČNIM RAMENOM

INOX
Keša

Br.	Specifikacija	
14060	0° - 180° · 150 x 200 mm	5
14070	0° - 180° · 300 x 500 mm	7



UGLOMER

HOBBY

Br.	Specifikacija	
14075	0° - 180° · 230 x 500 mm	30

NEW



VIŠENAMENSKI METAR

No.	Specification	
14077		1

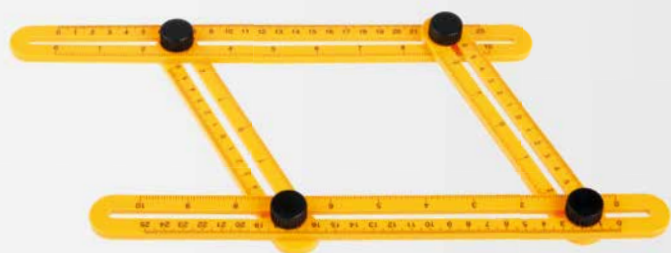

VIŠENAMENSKI METAR

Br.	Specifikacija	
14480	250 x 120 mm	1



ŠABLON ZA KOPIRANJE OBLIKA

Br.	Specifikacija	
14090	125 x 30 mm	1
14091	250 x 30 mm	1



FESTA

UGAONIK BRAVARSKI

ALU



Br.	Specifikacija	
14420	180 mm	10
14421	300 mm	10

NEW

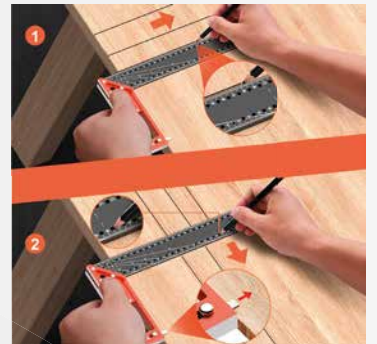
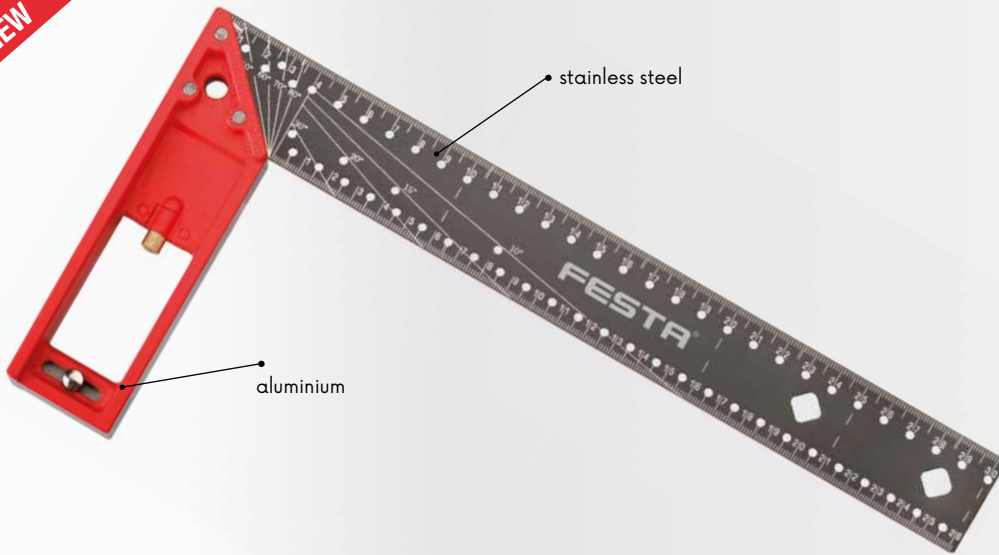

FESTA

UGAONIK STOLARSKI

INOX ALU



No.	Specification	
14415	300 mm	6
14417	400 mm	6

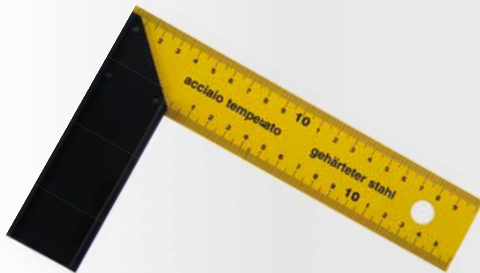

FESTA

UGAONIK STOLARSKI



Br.	Specifikacija	
14220	200 x 125 mm	10
14225	250 x 135 mm	10
14230	300 x 135 mm	10



FESTA

UGAONIK STOLARSKI



Br.	Specifikacija	
14350	500 x 235 mm	10
14360	600 x 300 mm	10
14370	700 x 300 mm	10

Br.	Specifikacija	
14380	800 x 320 mm	10
14399	1000 x 360 mm	10



FESTA
UGAONIK

ALU



Br.	Specifikacija	
14450	190 x 355 mm	6
14451	200 x 405 mm	6



FESTA
UGAONIK

ALU

Br.	Specifikacija	
14445	600 x 600 mm	1
14446	1200 x 1200 mm	1

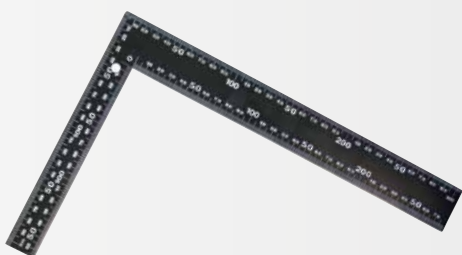

UGAONIK

Br.	Specifikacija	
14410	300 x 200 mm	50
14411	600 x 400 mm	36

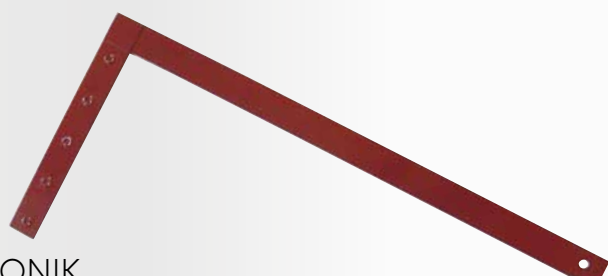

UGAONIK

Br.	Specifikacija	
14455	300 x 200 mm	50
14456	500 x 250 mm	50
14457	700 x 300 mm	40
14458	1000 x 450 mm	30



UGAONIK POCINKOVANI

Zn

Br.	Specifikacija	
14471	150 x 100 mm	25
14472	250 x 125 mm	25
14473	400 x 200 mm	30
14474	600 x 300 mm	25



UGAONIK POCINKOVANI SA NASLONOM

Zn

Br.	Specifikacija	
14490	100 x 50 mm	10
14491	150 x 75 mm	10
14492	250 x 125 mm	10
14493	400 x 200 mm	10
14494	600 x 300 mm	10



UGAONIK BRAVARSKI

ALU

HOBBY

Br.	Specifikacija	
14425	250 x 130 mm	12
14430	300 x 130 mm	12
14435	350 x 156 mm	12
14440	400 x 156 mm	12

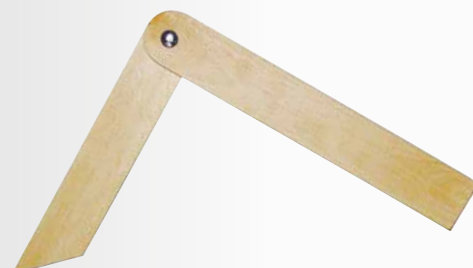

UGAONIK



Br.	Specifikacija	
14025	255 x 285 mm	1

HORIZONTAL® EXACTA

Precizno merenje nivoa sa najvećom tačnošću

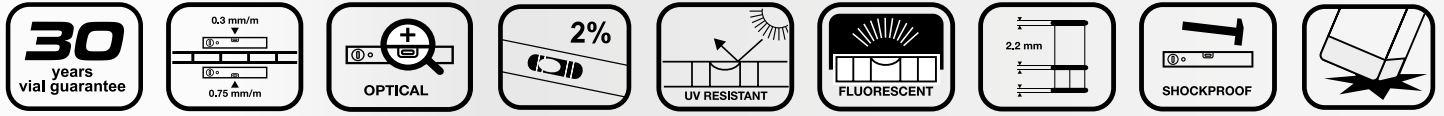

Svaki komad je elektronski testiran i ima svoj evidencioni broj, proizvođač je nosilac sertifikata ISO 9001.



HORIZONTAL® LIBELA EXACTA 1/2

Br.	Specifikacija	
15033	60 cm	10



HORIZONTAL® LIBELA EXACTA 1/3

Br.	Specifikacija	
15034	80 cm	10
15035	100 cm	10



HORIZONTAL® LIBELA EXACTA 1/3

Br.	Specifikacija	
15036	120 cm	10
15037	150 cm	10
15039	200 cm	10

HORIZONT®

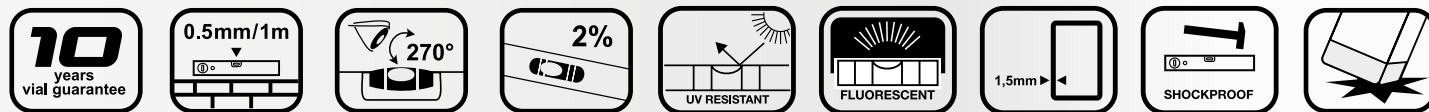

Svaki komad je elektronski testiran i ima svoj evidencioni broj, proizvođač je nosilac sertifikata ISO 9001.



HORIZONT® LIBELA, 2 LIBELE



Br.	Specifikacija	
15003	30 cm	30
15004	40 cm	30
15005	50 cm	30
15006	60 cm	30
15008	80 cm	30
15010	100 cm	30
15012	120 cm	10
15015	150 cm	10
15018	180 cm	10
15020	200 cm	10



HORIZONT® LIBELA, 3 LIBELE



Br.	Specifikacija	
15103	30 cm	30
15104	40 cm	30
15105	50 cm	30
15106	60 cm	30
15108	80 cm	30
15110	100 cm	30
15112	120 cm	10
15115	150 cm	10
15118	180 cm	10
15120	200 cm	10

**HORIZONT.**

LIBELA 1/2 SA MAGNETOM



Br.	Specifikacija	
15204	40 cm	30
15205	50 cm	30
15206	60 cm	30
15208	80 cm	30
15210	100 cm	30
15212	120 cm	10
15215	150 cm	10
15218	180 cm	10
15220	200 cm	10

**HORIZONT.**

LIBELA NAGIBNA 1/4



Br.	Specifikacija	
15230	80 cm	10

**HORIZONT.**

LIBELA NASLONSKA



Br.	Specifikacija	
15235	60 cm	1

**HORIZONT.**

LETVA ZIDARSKA



Br.	Specifikacija	
15310	100 cm	10
15315	150 cm	10
15318	180 cm	10
15320	200 cm	10
15325	250 cm	10
15330	300 cm	10
15335	350 cm	10
15340	400 cm	10



HORIZONT.

HORIZONT.

LETVA ZIDARSKA SA LIBELOM

ALU

Br.	Specifikacija	
15415	150 cm	10
15418	180 cm	10
15420	200 cm	10
15425	250 cm	10
15430	300 cm	10



HORIZONT.

HORIZONT.

LETVA ZIDARSKA SA LIBELOM 1/2

ALU

Br.	Specifikacija	
15510	100 cm	10
15515	150 cm	10
15518	180 cm	10
15520	200 cm	10
15525	250 cm	10
15530	300 cm	10
15535	350 cm	10
15540	400 cm	5



HORIZONT.

HORIZONT.

LETVA ZIDARSKA SA 2 RUKOHVATA

ALU

Br.	Specifikacija	
15615	150 cm	10
15620	200 cm	10
15625	250 cm	10
15630	300 cm	10



HORIZONT.

HORIZONT.

LETVA ZIDARSKA SA 2 RUKOHVATA +2 LIBELE

ALU

Br.	Specifikacija	
15710	100 cm	10
15715	150 cm	10
15720	200 cm	10
15725	250 cm	10
15730	300 cm	10
15735	350 cm	10
15740	400 cm	5

NEW

HORIZONT.

UGAONIK

ALU



Br.	Specifikacija	
14485	800 x 1200 mm	1
14486	1000 x 1500 mm	1

**HORIZONT.**

LETVA ZIDARSKA TRAPEZ

PROFILE TRAPEZOIDAL

- trapezoidal profile for finer surface finishes
- suitable for stucco and facades
- suitable for thin-film plasters

ALU

Br.	Specifikacija	
15810	100 cm	10
15812	120 cm	10
15815	150 cm	10
15818	180 cm	10
15820	200 cm	10
15825	250 cm	10
15830	300 cm	10

**HORIZONT.**

LETVA ZIDARSKA „h“ PROFIL

PROFILE „h“

- „h“ profile for finer surface finishes
- suitable for stucco and facades
- suitable for stucco plastering

ALU

Br.	Specifikacija	
15850	100 cm	10
15853	150 cm	10
15855	180 cm	10
15860	200 cm	10
15870	250 cm	10
15880	300 cm	10

**HORIZONT.**REKLAMNA POLICA
ZA LIBELE HORIZONT

· Ispunjen sa stavkama 15998

15003	· 5 kom
15004	· 5 kom
15005	· 5 kom
15006	· 5 kom
15008	· 5 kom
15010	· 5 kom
15012	· 5 kom
15015	· 3 kom
15018	· 3 kom
15020	· 3 kom
15108	· 3 kom
15206	· 3 kom
15210	· 3 kom

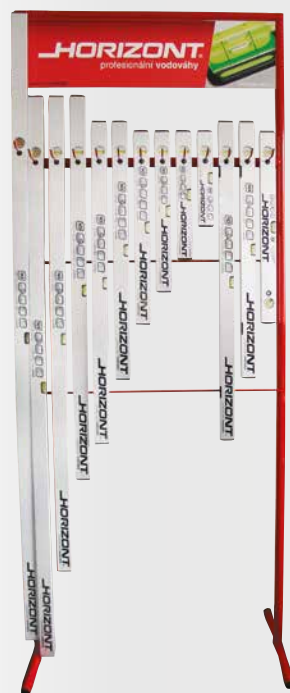
**HORIZONT.**REKLAMNA POLICA
ZA LIBELE HORIZONT

· Ispunjen sa stavkama 15996

15004	· 5 kom
15005	· 5 kom
15006	· 5 kom
15008	· 5 kom
15010	· 5 kom
15012	· 5 kom
15015	· 5 kom
15018	· 5 kom
15020	· 5 kom
15315	· 2 kom
15320	· 2 kom
15325	· 3 kom
15515	· 2 kom
15520	· 2 kom
15525	· 3 kom



Br.	Specifikacija	
15999	85 x 210 x 50 cm	1
15998	85 x 210 x 50 cm sa libeli i letvi	1

Br.	Specifikacija	
15997	55 x 75 x 40 cm	1
15996	55 x 75 x 40 cm sa libeli i letvi	1

- Tačnost 0,5 mm | 1 m (u normalnom položaju)
- Tečnost u bocici je UV otporan
- Gumeni završetak, otporan na udarce
- Debljina, grim profil 1,2 mm



NIVELA

LIBELA 1/2

- Gumeni završetak



Br.	Specifikacija	
15904	40 cm	30
15906	60 cm	30
15908	80 cm	30
15910	100 cm	30
15912	120 cm	20
15915	150 cm	10
15920	200 cm	20



LIBELA 1/3



Br.	Specifikacija	
15954	40 cm	60
15956	60 cm	60
15958	80 cm	60
15960	100 cm	30
15962	120 cm	30
15965	150 cm	30
15970	200 cm	30



DIGITALNA LIBELA DL

- Tačnost 0,5 mm/m
- Rezolucija 0,1°
- HOLD funkcija za čuvanje izmerene vrednosti
- Debljina profila 1,8 mm



9V



Br.	Specifikacija	
26215	600 mm	1



LIBELA ZA KANAP



Br. Specifikacija

15981



1



Br. Specifikacija

15980

230 mm



1

LIBELA 1/3 SA MAGNETOM



LIBELA ZA ŠTAPOVE

- 3 libele, magnet, traka za učvršćivanje



Br. Specifikacija

26028



12

CREVASTA LIBELA



Br.	Specifikacija	
15992	Staklena cjevčica- crijevo 10 m	1
15993	Staklena cjevčica- crijevo 10 m	1
15990	Staklena cjevčica	50
15991	Plastična cjevčica	50

FESTA

DIGITALNI INCLINOMETAR

- 0° - 360°
- Tačnost ±0,1°
- Rezolucija 0,1°
- Funkcija automatskog isključivanja
- HOLD funkcija za čuvanje izmerene vrednosti
- Ekran sa pozadinskim osvetljenjem
- Dimenzije 60x60x25 mm
- Baterija 1xAAA



· bag

· Magnetska donja strana



Br. Specifikacija

26218



1

FESTA

DIGITALNI PROTRACTOR

- LCD
- Merni opseg 0° - 360°
- Razlika 0,1°
- Tačnost ± 0,3



Br. Specifikacija

26217 200 mm



1

FESTA

DIGITALNI PROTRACTOR

- LCD
- Merni opseg 0° - 225°
- Razlika 0,1°
- Tačnost ± 0,3



Br. Specifikacija

26216 300 mm



1

NEW

**FESTA****LASER ALL LINE GREEN 3 X 360 °**

- 1k horizontalna ravan + 2k vertikalna ravan (zeleni snop)
- samonivelirajući opseg $\pm 4^\circ$
- tačnost 0,2 mm/m
- unutrašnja: 30 m, spoljašnja sa detektorom 50 m
- pulsni režim – preporučeni dodatni prijemnik 26209
- uključeno: torbica, 4kAA alkalne baterije, laserska meta, zaštitne naočare, 2600 mAh Li-ion baterija, profesionalni nosač, punjač, postolje Li-ion baterije



No. Specification

26204



1

NEW

**FESTA****CROSS-LINE GREEN LASER**

- 1k horizontalna ravan + 1k vertikalna ravan (zeleni snop)
- samonivelirajući opseg $\pm 3^\circ$
- tačnost 0,2 mm/m
- unutrašnja: 20 m, spoljašnja sa detektorom 50 m
- pulsni režim – preporučeni dodatni prijemnik 26209
- Uključeno: torbica za nošenje, 2kAA alkalne baterije, nosač



No. Specification

26201



1

NEW

**FESTA****LASERSKI PRIJEMNIK**

- za upotrebu sa impulsnim laserskim uređajima za proširenje dometa od 50 m
- uključujući: 9 V baterija, nosač
- za 26201, 26204



No.	Specification
26209	range: 50 m



1

NEW

Laser

**FESTA****DALJINOMER**

- meri opseg 0,05 - 50 m
- tačnost merenja ± 2 mm, merna jedinica mm/in/ft
- kontinuirano merenje, merenje površine, merenje zapremine,
- Merenje noge trougla, LCD FSTN, sabiranje/oduzimanje, maks./min. meas
- urement, mak skladištenje 100 jedinica, pozadinsko osvetljenje, klasa lasera 630-670 nm klasa 2
- radna temperatura 0 - 40°C
- veličina 112 k 50 k 25 mm, težina 90 g
- uključujući: torbicu za nošenje, 2kAAA alkalne baterije



No.	Specification
26211	



1

Laserliner®

LUXTEST-MASTER

Professional lighting intensity measuring instrument

- Measurement of lighting intensity in workplaces, offices, public buildings and industry
- Sensitive photodiode with cosine correction for wide-angle light measurement
- Relative measurement function for reference and comparison measurement
- Peak function for registering fast changes in light levels
- Hold function
- Automatic and manual range changeover
- Zeroing function
- Measurement variables: Lux (lm |m 2), foot candle (lm |ft 2)
- Min |Max displayj
- 1 |4" tripod connection

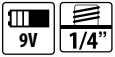

Br.	Specifikacija	
	Measuring range	20 Lux ... 200000 Lux
26520	Lux accuracy	± 3% (референтна стойност 2854 K) (reference light bulb at 2854 K)
	Cosine angular deviation:	± 2% (30°), ± 6% (60°)



Specifikacija	
Inclusive:	battery, carrying case

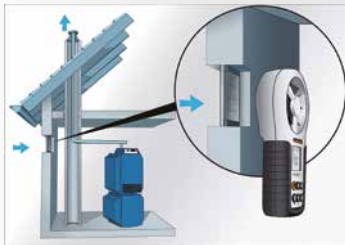

Laserliner®

AIRFLOWTEST-MASTER

Professional anemometer for measuring air flow, volumetric flow and wind speed

- Integrated sensor for measuring ambient temperature, relative humidity and dew point calculation
- USB interface for saving measured data
- PC software for real-time logging
- Large impeller: 65 mm
- Min |Max display
- 1 |4" tripod connection for long-term measurement
- Illuminated, clearly arranged display with permanently visible ambient temperature and relative humidity



Br.	Specifikacija	
	Flow rate:	0.80...30 m s ± 2%
26521	Ambient temperature	-10...60°C ± 1.5°C
	Relative humidity:	20%...80% ± 3%
	Airflow :	0...99990 CMM



Specifikacija	
Inclusive:	PC software, USB Cable, batteries, carrying case



RECORDING ON A PC

Laserliner®

CONDENSESPOT PLUS

Infrared thermometer for locating thermal bridges and condensation moisture

- 8-point laser circle pinpoints the measuring zone exactly
- Measurement of surface |dew point temperature
- Localisation of condensation in thermal bridge mode with dew point display
- Localisation of thermal bridges and condensation water issues in thermal bridge mode with dew point display
- Temperature measurement range (-40°C...365°C)
- Emission ratio: 0.01...1.0 (adjustable)
- Colour alarm function: Thermal bridge warning with colour display
- Quick selection of 5 emissivity defaults with Fast Preset or exact setting by entering numerical value
- Bar graph condense water indicator
- Lens 12:1, illuminated display

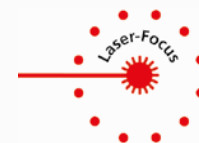

1

Br.	Specifikacija	
	Measuring range of infrared ray	-40°C ... 365°C
	Accuracy:	± -40°C ... 0°C (± 1°C + 0,1°C 1°C)) 0°C ... 30°C (± 1°C or ± 1%, depending on the higher value) >30°C (± 2°C or ± 2%, depending on the higher value)
26528	Ambient temperature Accuracy	-20°C...65°C ± 1°C (0°C...50°C) ± 2,5°C (<0°C / >50°C)
	Air humidity (relative) Accuracy	1%...99% ± 3% (20%...80%) ± 5% (<20% / >80%)
	Inclusive:	battery



Laserliner®

COMPACTCROSS - LASER PLUS

The automatic cross-line laser for aligning tiles, wall studding, windows, doors etc.

- The slope-mode feature is an extra that permits gradients to be laid out.
- RX-ready: integrated hand-held receiver mode
- Bluetooth® interface for remote control of the device
- Automatic levelling range 4°, Accuracy 0,35 mm |m



1

Br.	Specifikacija	
26037	Inclusive:	battery



FESTA

ALAT ZA OBELEŽAVANJE



Br.	Specifikacija	
13262	150 mm	20

NEW



FESTA

OLOVKE U BOJI

pro 13262



Č.p.	Specifikace	
13267	2x žlutá 2x červená 2x modrá	1



FESTA

OLOVKA ZA OBELEŽAVANJE HB



Br.	Specifikacija	
13279	pencil + graphite HB	24
13284	spare graphite 5 pcs	20



FESTA

CRNE OLOVKE HB

pro 13262



Č.p.	Specifikace	
13263	6x černá	20



FESTA

OLOVKA TESARSKA HB



Br.	Specifikacija	
13270	HB · 180 mm	96
13271	HB · 180 mm · set 3pcs	32
13265	HB · 250 mm	96



FESTA

OLOVKA TESARSKA HB



Br.	Specifikacija	
13269	HB · 180 mm	50
13266	HB · 250 mm	50



FESTA

OLOVKA TESARSKA HB



MOQ
12

Br.	Specifikacija	
13272	HB · 250 mm	96
13264	HB · 250 mm · bez štampe	96



FESTA

OLOVKA TESARSKA HB



MOQ
50

Br.	Specifikacija	
13268	250 mm	50



FESTA

TROUGLASTA OLOVKA HB

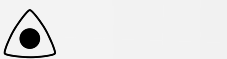

MOQ
12

Br.	Specifikacija	
13278	250 mm	96



OLOVKA TESARSKA HB



MOQ
12

Br.	Specifikacija	
13280	180 mm	96



FESTA

OLOVKA ZA KAMEN 6H



MOQ
12

Br.	Specifikacija	
13275	6H · 250 mm	96



FESTA

CRVENA OLOVKA ZA STAKLO I KARAMIKU



MOQ
12

Br.	Specifikacija	
13273	175 mm crvena olovka za staklo i karamiku	144

**FESTA**

OLOVKA

MOQ
12

Br.	Specifikacija
13274	175 mm, črveno - plava



96



OLOVKA

MOQ
12

Br.	Specifikacija
13276	175 mm



144



· Brusni papir

OŠTRAČ ZA OLOVKE

Br.
13261



12



PERMANENTNI MARKER



- Ekstra jak vrh
- Za obeležavanje čak i na masnim i mokrim površinama



MOQ
12

Br.	Specifikacija	
13216	Crveni	12
13217	Crni	12
13218	Plavi	12
13219	Zelen	12



PERMANENTNI MARKER



- 2 tipa vrha markera
- Za obeležavanje čak i na masnim i mokrim površinama



Br.	Specifikacija	
13227	Beli ALU	40
13222	Beli PVC	12
13228	Crveni ALU	40
13229	Crni ALU	40
13230	Plavi ALU	12
13231	Zelen ALU	12



PERMANENTNI MARKER



MOQ
12



Br.	Specifikacija	
13214	Beli	12
13225	Crveni	12
13226	Crni	12
13223	Plavi	12
13224	Zelen	12



PERMANENTNI MARKER



MOQ
12



Br.	Specifikacija	
13235	Crveni	12
13236	Crni	12
13237	Plavi	12
13238	Zelen	12



NEW

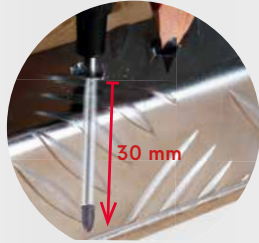

NEW



PERMANENTNI MARKER, 2 TIPA VRHA

MOQ
12



Br. I No. Specifikacija
13206 ○ Beli



FESTA

PERMANENTNI MARKER



Br. I No. Specifikacijaw
13246 ● Crni



10

NEW

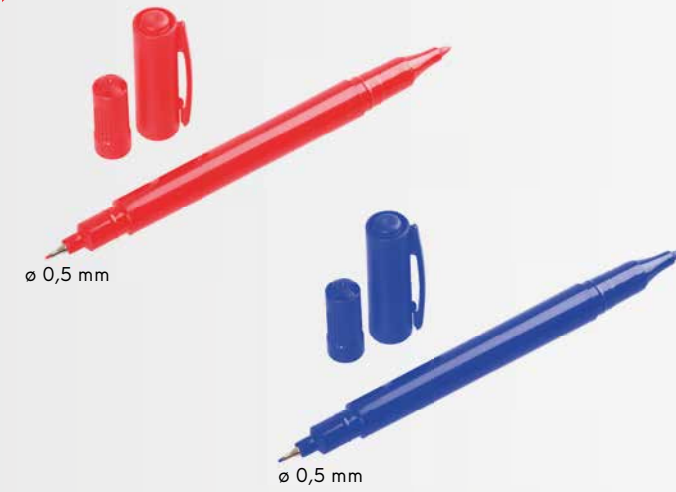

PERMANENTNI MARKER, 2 TIPA VRHA

MOQ
12



Br. I No. Specifikacija
13207 ● Crveni
13208 ● Plavi



PERMANENTNI MARKER MINI



· Dužina 9 cm



Br. Specifikacija
13205 ● ● ● ●

MOQ
72



PERMANENTNI MARKER, 2 TIPA VRHA

MOQ
12



Br. Specifikacija
13212 Crni





FESTA

ALAT ZA OBELEZAVANJE



Br.	Specifikacija	
13281	150 mm	50



ŠESTAR ZA OCRTAVANJE



Br.	Specifikacija	
13285	200 mm	10



FESTA

ALAT ZA OBELEZAVANJE



Br.	Specifikacija	
13282	200 mm	50



KREDA BELA

12x



Br.	Specifikacija	
13260	12 x 12 x 80 mm	46



FESTA

KOMPLET OLOVAKA 5 KOM

· Ø 13 x 110 mm

5x



Br.	Specifikacija		Br.	Specifikacija	
13240	5 boja	20	13243	žut	20
13241	● Crveni	20	13244	● Zelen	20
13242	● Crni	20	13245	○ Beli	20



KOMPLET OLOVAKA 6 KOM

6x



Br.	Specifikacija	
13277	● ● ○ ● ● ●	88

FLUORESCENTNI SPREJ TRACKMARKER 500ML

- Dobra vidljivost zbog fluorescentnog pigmenta
- Bezbednost kapa
- Brzo sušenje 10 min.
- Trajnost 3 mesecis
- Primena - beton, asfalt, trava, šljunak, pesak, kamen, drvo

MADE IN EU



Br.	Specifikacija	
13250	● žuti	12
13251	● Crveni	12
13252	● narandžasta	12
13253	● Zelen	12
13254	● Roze	12
13249	● Plavi	12



FLUORESCENTNI SPREJ MARK 6M FLUO 500 ML

- Dobra vidljivost zbog fluorescentnog pigmenta
- Bezbednost kapa
- Brzo sušenje 10 min.
- Trajnost 12 mesecis
- Primena - beton, asfalt, trava, šljunak, pesak, kamen, drvo

MADE IN EU



Br.	Specifikacija	
13360	● žuti	12
13361	● Crveni	12
13362	● narandžasta	12
13363	● Zelen	12
13364	● Roze	12
13365	○ Beli	12



FLUORESCENTNI SPREJ FLUO 500 ML

- Dobra vidljivost zbog fluorescentnog pigmenta
- Bezbednost kapa
- Brzo sušenje 10 min.
- Trajnost 12 mesecis
- Primena - beton, asfalt, trava, šljunak, pesak, kamen, drvo

MADE IN EU



Br.	Specifikacija	
13350	● žuti	12
13351	● Crveni	12
13352	● narandžasta	12
13353	● Zelen	12
13354	● Roze	12
13355	○ Beli	12



FLUORESCENTNI SPREJ IDEAL 500ML

- Dobra vidljivost zbog fluorescentnog pigmenta
- Bezbednost kapa
- Brzo sušenje 10 min.
- Trajnost 12 mesecis
- Primena - beton, asfalt, trava, šljunak, pesak, kamen, drvo



Br.	Specifikacija	
13255	žuti	12
13256	Crveni	12
13257	narandžasta	12
13258	Zelen	12
13259	Roze	12



DRŽAČ ZA SPREJ

- For spray trackmarker and Fluo



Br.	Specifikacija	
13296		1

DRŽAČ SPREJA SA PIŠTOLJEM

- For spray trackmarker and Fluo



Br.	Specifikacija	
13295		1



60

KLEŠTA



66

VODOVODNA KLEŠTA



68

MAKAZE ZA ARMATURU



70

MAKAZE



73

SETOVI GEDORE



82

NASTAVCI GEDORA



87

KLJUČEVI



93

ODVIJAČI



101

STAHLBERG BITOVI,
KOMPLET BITOVI

110

IMBUS KLJUČEVI



115

ČEKIĆI

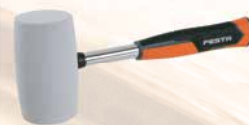

120

ČEKIĆI GUMENI



122

SEKIRE



125

KUKKE ZA EKOMERE



126

DLETA

ALATI

58 - 159



129

HEFTALICE



131

STEGE



134

RADNI STOL



136

KLESTA ZA POP NITNE



140

ELEKTRODE, MASKE ZA VARENJE

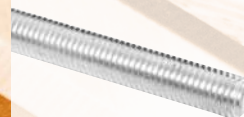

143

NAVOJNE ŠIPKE



144

PIŠTOLJI ZA FARBANJE,
PNEUMATSKI PISTOLJI

149

ZAŠTITNA OPREMA I
ŠTITNICI ZA KOLJENA

155

POJASEVI ZA ALAT I TORBE

FESTA®



ERGONOMIC handle

FESTA
KLJEŠTA KOMBINOVANA

Br.	Specifikacija	
17101	160 mm	6
17102	180 mm	6
17103	200 mm	6

FESTA
KLJEŠTA SEČICE



Br.	Specifikacija	
17148	180 mm	6

FESTA
KLJEŠTA SEČICE

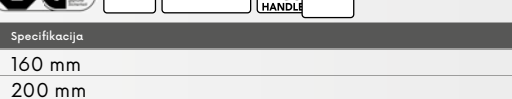

Br.	Specifikacija	
17104	160 mm	6
17105	180 mm	6

FESTA
KLJEŠTA ŠPICASTA

Br.	Specifikacija	
17140	160 mm	6
17142	200 mm	6

FESTA
KLJEŠTA ŠPICASTA SAVIJENA

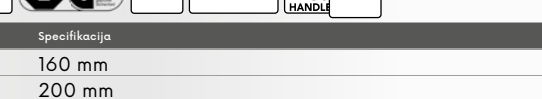
Br.	Specifikacija	
17145	160 mm	6
17146	200 mm	6





FESTA

KLJEŠTA KOMBINOVANA

DIN 5746	TUV GS HRC 50-55 ERGO HANDLE	
Br.	Specifikacija	
17001	160 mm	6
17002	180 mm	6
17003	200 mm	6



FESTA

KLJEŠTA SEČICE

DIN 5749	TUV GS HRC 50-55 ERGO HANDLE	
Br.	Specifikacija	
17004	160 mm	6
17005	180 mm	6



FESTA

KLJEŠTA SEČICE

DIN 5749	TUV GS HRC 50-55 ERGO HANDLE	
Br.	Specifikacija	
17108	180 mm	6



FESTA

KLJEŠTA SEČICE

DIN 5749	TUV GS HRC 50-55 ERGO HANDLE	
Br.	Specifikacija	
17110	160 mm	6



FESTA

KLJEŠTA ŠPICASTA

DIN 5745	TUV GS HRC 50-55 ERGO HANDLE	
Br.	Specifikacija	
17006	160 mm	6
17011	200 mm	6



FESTA

KLJEŠTA ŠPICASTA SAVIJENA

DIN 5745	TUV GS HRC 50-55 ERGO HANDLE	
Br.	Specifikacija	
17007	160 mm	6
17008	200 mm	6



FESTA

KLJEŠTA RAVNA

DIN 5746	TUV GS HRC 50-55 ERGO HANDLE	
Br.	Specifikacija	
17009	160 mm	6



FESTA

KLJEŠTA S OKRUGLIM NOSOM

DIN 5745	TUV GS HRC 50-55 ERGO HANDLE	
Br.	Specifikacija	
17010	160 mm	6



FESTA

KLJEŠTA ZA SKID.IZOLACIJE

DIN 5744	TUV GS ERGO HANDLE	
Br.	Specifikacija	
17024	160 mm	6



KLJEŠTA KOMBINOVANA

DIN 5746	TUV GS	
Br.	Specifikacija	
17094	160 mm	6
17095	180 mm	6
17096	200 mm	6



KLJEŠTA SEČICE

DIN 5749	TUV GS	
Br.	Specifikacija	
17097	160 mm	6
17098	180 mm	6



KLJEŠTA ŠPICASTA

DIN 5745	TUV GS	
Br.	Specifikacija	
17099	160 mm	6
17100	200 mm	6

**FESTA**

VDE KLJEŠTA KOMBINOVANA

△ 1000 V
IEC/EN60900:2004

DIN 5746

CrV

HRC 58-62



Br.	Specifikacija	
17125	160 mm	6
17126	180 mm	6
17127	200 mm	6

**FESTA**

VDE KLJEŠTA SEČICE

△ 1000 V
IEC/EN60900:2004

DIN 5749

CrV

HRC 58-62



Br.	Specifikacija	
17128	160 mm	6

**FESTA**

VDE MAKAZE ZA ŽICU

△ 1000 V
IEC/EN60900:2004

CrV

HRC 58-62



Br.	Specifikacija	
17130	160 mm	6

**FESTA**

VDE KLJEŠTA ŠPICASTA

△ 1000 V
IEC/EN60900:2004

DIN 5745

CrV

HRC 58-62



Br.	Specifikacija	
17133	160 mm	6

**FESTA**

VDE KLJEŠTA ŠPICASTA SAVIJENA

△ 1000 V
IEC/EN60900:2004

DIN 5745

CrV

HRC 58-62



Br.	Specifikacija	
17135	160 mm	6

**FESTA**

VDE KLEŠTA ELEKTRIČARSKA

△ 1000 V
IEC/EN60900:2004

DIN 5745

CrV

HRC 58-62



Br.	Specifikacija	
17137	160 mm	6

**FESTA**

VDE KLJEŠTA ZA SKIDANJE IZOLACIJE

△ 1000 V
IEC/EN60900:2004

CrV

DIN 5744



Br.	Specifikacija	
17138	160 mm	6



AUTOMATSKI SKIDAČ IZOLACIJE

Br.	Specifikacija	
17180	Ø 0,75 - 2,5 mm	12



MAKAZE ZA SKIDANJE IZOLACIJE I SEČENJE

Br.	Specifikacija	
17181	Ø 0,60 - 2,6 mm	10

NEW**FESTA**

SKIDAČ IZOLACIJE

AWG	mm ²
10	6,0
12	4,0
14	2,5
16	1,5
18	1,0
20	0,5

- RG6/59 koakomijalni kabl
- niskonaponski kabl Ø 8 - 13 mm

Br.	Specifikacija
16202	125 mm



10

NEW



FESTA

KLEŠTA ZA FINE KABLOVE

max Ø 0,2 - 2,1 mm

CrV

Br. / No.	Specifikacija / Specification	
17047	140 mm	10



FESTA

KLJEŠTA MINI



Br.	Specifikacija	
17041	110 mm	12



FESTA

KLJEŠTA MINI



Br.	Specifikacija	
17042	110 mm	12



FESTA

KLJEŠTA MINI



Br.	Specifikacija	
17043	100 mm	12



FESTA

KLJEŠTA MINI



Br.	Specifikacija	
17044	120 mm	12



FESTA

KLJEŠTA MINI



Br.	Specifikacija	
17045	120 mm	12



FESTA

KLEŠTA MINI KOMPLET

4x

Br.	Specifikacija	
17040		6



FESTA

KLJEŠTA ZA ZEGER



Br.	Specifikacija	
17190	180 mm unutrašnja	6
17191	180 mm spoljašnja	6



FESTA

KLJEŠTA ZA ZEGER



Br.	Specifikacija	
17192	180 mm unutrašnja	15
17193	180 mm spoljašnja	15



Br.	Specifikacija	
17025	sada	10

**FESTA****MULTIFUNKCIONALNE KLIJEŠTA**

- 9 funkcija
- Futrola

CrV

Br. Specifikacija

16232



12

FESTA**KLEŠTA
MULTIFUNKCIONALNA**

- Za postavljanje ograde

CrV

Br. Specifikacija

17109 270 mm



4

**KLJEŠTA JAKOSTEZAJUĆA**

Br. Specifikacija

17034 220 mm



5

**KLJEŠTA JAKOSTEZAJUĆA**

Br. Specifikacija

17036 260 mm



5

**KLJEŠTA JAKOSTEZAJUĆA**

Br. Specifikacija

17035 220 mm



10

**KLJEŠTA JAKOSTEZAJUĆA**

Br. Specifikacija

17023 220 mm



6



FESTA

KLJEŠTA PAPAGAJKE

CrV

Br.	Specifikacija	Otvor čeljusti	
17059	180 mm	0 - 30 mm	6
17061	250 mm	0 - 30 mm	6
17062	300 mm	0 - 40 mm	6
17080	400 mm	0 - 84 mm	4



FESTA

KLJEŠTA PAPAGAJKE

CrV

Br.	Specifikacija	Otvor čeljusti	
17084	250 mm	0 - 30 mm	6



FESTA

KLJEŠTA PAPAGAJKE

CrV

· large range of jaws

Br.	Specifikacija	Otvor čeljusti	
17086	250 mm	0 - 50 mm	6



FESTA

KLJEŠTA PAPAGAJKE

CrV

Br.	Specifikacija	Otvor čeljusti	
17081	180 mm	0 - 30 mm	6
17014	250 mm	0 - 30 mm	6
17082	300 mm	0 - 50 mm	6



FESTA

KLJEŠTA PAPAGAJKE

CrV

Br.	Specifikacija	Otvor čeljusti	
17079	250 mm	0 - 50 mm	6



FESTA

KLJEŠTA PAPAGAJKE

CrV

Br.	Specifikacija	Otvor čeljusti	
17012	250 mm	0 - 40 mm	6
17060	300 mm	0 - 50 mm	10



KLJEŠTA PAPAGAJKE

Br.	Specifikacija	Otvor čeljusti	
17013	250 mm	0 - 30 mm	6
17033	300 mm	0 - 50 mm	6



PLASTIČNE ČELJUSTI ZA KLJEŠTA PAPAGAJKE

· Pogodno za 17061, 17079

Br.	Specifikacija	
17085	1 par	1

**FESTA**

VODOVODNA KLEŠTA 45°, S

CrV



Br.	Specifikacija	
17067	1" 330 mm	1
17068	1,5" 420 mm	1
17069	2" 540 mm	1

**FESTA**

VODOVODNA KLEŠTA 90°

CrV



Br.	Specifikacija	
17075	1" 330 mm	1
17076	1,5" 420 mm	1
17077	2" 540 mm	1

**FESTA**

VODOVODNA KLEŠTA 90°

CrV



Br.	Specifikacija	
17070	2,5" 355 mm	12
17071	3" 455 mm	8
17072	3,5" 610 mm	10

**FESTA**

VODOVODNA KLEŠTA 90°

CrV

Br.	Specifikacija	
17063	230 mm	6
17064	300 mm	6



VODOVODNA KLEŠTA 90°

Br.	Specifikacija	
17065	260 mm	36
17066	300 mm	36

FESTA

MAKAZE ZA ŽICU

- Čelična žica
- ACSR kabel
- Avio kablovi

CrV

max. Ø
12 mm

Br.	Specifikacija	
17039	24' 610 mm	8

**FESTA**

MAKAZE ZA ŽICU

- Čelična žica
- ACSR kabel
- Avio kablovi

CrV

max. Ø
6 mm

Br.	Specifikacija	
17029	200 mm	6

**FESTA**

MAKAZE ZA ARMATURU

- Čeljusti za kablove i žice

Cr-Mo

HRC 58-62



Br.	Specifikacija	max. Ø drátu	max. Ø lanka	max. Ø kabela	
17055	14' 360 mm	max. 5 mm < 45 HRC	max. 3,5 mm	max. 8 mm	1
17056	18' 460 mm	max. 6 mm < 45 HRC	max. 5 mm	max. 10 mm	1
17057	24' 610 mm	max. 8 mm < 45 HRC	max. 7 mm	max. 12 mm	1
17058	30' 760 mm	max. 10 mm < 45 HRC	max. 9 mm	max. 14 mm	1
17046	35' 900 mm	max. 12 mm < 45 HRC	max. 10 mm	max. 16 mm	1

**FESTA**

MAKAZE ZA ARMATURU

Cr-Mo

HRC 58-62



Br.	Specifikacija	max. Ø drátu	
17051	14' 360 mm	max. 5 mm < 45 HRC	1
17052	18' 450 mm	max. 6 mm < 45 HRC	1
17053	24' 610 mm	max. 8 mm < 45 HRC	1
17054	30' 760 mm	max. 10 mm < 45 HRC	1
17048	36' 910 mm	max. 12 mm < 45 HRC	1



MAKAZE ZA ARMATURU



Br.	Specifikacija	max. Ø drátu	
17028	14' 350 mm	max. 5 mm < 30 HRC	30
17020	18' 450 mm	max. 6 mm < 30 HRC	6
17021	24' 610 mm	max. 8 mm < 30 HRC	10
17022	30' 760 mm	max. 10 mm < 30 HRC	5



NEW



FESTA

MAKAZE ZA ARMATURU

- meka žica: \varnothing 6 mm
- srednje tvrda žica: \varnothing 5 mm
- tvrda žica: \varnothing 4 mm

CrV

Br.	Specifikacija
17078	200 mm



MAKAZE ZA ARMATURU

max. \varnothing
5 mm

Br.	Specifikacija
17038	8' 210 mm



FESTA

KLJEŠTA STOLARSKA

CrV

Br.	Specifikacija
17300	160 mm
17301	180 mm
17302	200 mm
17303 NEW	250 mm



FESTA

KLJEŠTA ARMIRAČKA

CrV

Br.	Specifikacija
17305	220 mm
17306 NEW	250 mm
17304	275 mm



KLJEŠTA STOLARSKA

Br.	Specifikacija
17015	160 mm
17016	180 mm
17017	200 mm



KLJEŠTA ARMIRAČKA

Br.	Specifikacija
17019	220 mm
17083	275 mm



FESTA

KLESTA ZA LIM PRAVA

Br.	Specifikacija
17089	150 x 215 mm



2



FESTA

KLESTA ZA LIM PRAVA

Br.	Specifikacija
17093	95 x 270 mm



6



FESTA

KLESTA ZA LIM PRAVA

Br.	Specifikacija
17090	60 x 280 mm



10



FESTA

KLESTA ZA LIM OD 45°

Br.	Specifikacija
17091	60 x 280 mm



10



FESTA

KLESTA ZA LIM OD 90°

Br.	Specifikacija
17092	60 x 260 mm



10



FESTA

MAKAZE ZA LIM

Cr-Mo **HRC 58-62**



Br.	Specifikacija
17112	Prave 40 260 mm
17117	Desne 40 260 mm
17122	Leve 40 260 mm



FESTA

MAKAZE ZA LIM

Cr-Mo **HRC 58-62**



Br.	Specifikacija
17111	Prave 40 250 mm
17116	Desne 40 250 mm
17121	Leve 40 250 mm



FESTA

MAKAZE ZA LIM

CrV



Br.	Specifikacija	
17170	50 250 mm	6



FESTA

MAKAZE ZA LIM

CrV



Br.	Specifikacija	
17156	60 245 mm	6



FESTA

MAKAZE ZA LIM

CrV



Br.	Specifikacija	
17155	70 260 mm	6



MAKAZE ZA LIM

CrV

Br.	Specifikacija	
17167	70 300 mm	5



MAKAZE ZA LIM

CrV

Br.	Specifikacija	
17165	60 250 mm	5



MAKAZE ZA LIM

CrV

Br.	Specifikacija	
17169	35 250 mm	5



MAKAZE ZA LIM

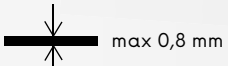

Br.	Specifikacija	
17186	265 mm	6

ADAPTER ZA SEČENJE PLOČA

- Max. debljina ploče
- 1,8 mm - Čelik
 - 1,2 mm - Nehrđajući
 - 2 mm - Plastika, ALU, bakar



Br.	Specifikacija	
20363		5

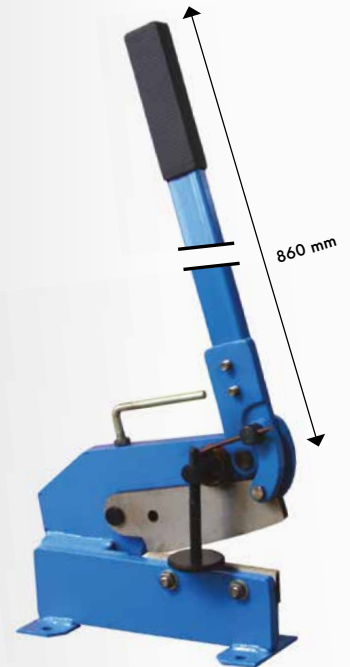

MAKAZE ZA LIM SA POLUGOM

	17175	17177
	Max. 4 mm	5 mm
	Max. Ø10 mm	Ø12 mm
	Max. 8x8 mm	10x10 mm

Br.	Specifikacija	
17175	150 mm	1
17177	250 mm	1



FESTA

MAKAZE ZA BUŠENJE RUPA



Br.	Specifikacija	
17185	Ø 2; 2,5; 3; 3,5; 4; 4,5 mm	12



FESTA

KLEŠTA ZA PVC PROFIL

· Letvice, cevi, profili



Br.	Specifikacija	
17050	60 220 mm ø 17 mm, ø 20 mm, ø 27 mm	8



MAKAZE TEHNIČKE

INOX



Br.	Specifikacija	
16420	60 200 mm	12



TEHNIČKE MAKAZICE

INOX



Br.	Specifikacija	
17159	65 220 mm	12



TEHNIČKE MAKAZICE

INOX



Br.	Specifikacija	
17158	50 150 mm	10



MAKAZE

INOX

3x



Br.	Specifikacija	
16401	3 kom	48



TEHNIČKE MAKAZICE

INOX



Br.	Specifikacija	
17160	70 210 mm	12



MAKAZE

INOX

Br.	Specifikacija	
16405	14 cm	24
16406	17 cm	24
16407	19 cm	24
16408	21,5 cm	12

FESTA®

10 years guarantee

- For industry and services
- High quality Chrom Vanadium steel
- Ratchet with 72 teeth for the most precise work
- All components according to DIN norm
- Knurled heads for better grip
- Strong plastic or metal case

made by

HONITON

FESTA made by **HONITON**

GEDORA KOMPLET

- 1/2" · 72 T
- 1/2" · 125 mm
- 1/2" · 8-9-10-11-12-13-14-15-17-19-22 mm

CrV 1/2" 13x

Br. 17210 Specifikacija



10 years guarantee



1

FESTA made by **HONITON**

GEDORA KOMPLET

- 1/4" · 72 T
- 1/4" · 50 mm, 100 mm
- 1/4"
- 1/4" · 4-4,5-5-5,5-6-7-8-9-10-11-12-13 mm

CrV 1/4" 17x

Br. 17211 Specifikacija









10 years guarantee

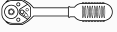

1

FESTA made by **HONITON**

GEDORA KOMPLET

-  1/2"
-  1/2" · 125 mm, 250 mm
-  1/2"
-  16 mm, 21 mm
-  1/2"
-  1/2" · 10-11-12-13-14-15-16-17-18-19-20-21-22-23-24-27-30-32 mm

CrV **1/2"** **25x**

Br. Specifikacija
17212











10 years guarantee

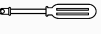

4

FESTA made by **HONITON**

GEDORA KOMPLET

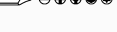
-  1/2", 1/4" · 72 T
-  1/2", 1/4"
-  1/4" · 150 mm
-  1/4" · 100 mm
-  1/2", 1/4"
-  1/2" · 125 mm, 250 mm
-  1/4" · 4-4,5-5-5,5-6-7-8-9-10-11-12-13 mm
-  1/2" · 10-11-12-13-14-15-17-19-21-22-24-27-30-32 mm
-  16 mm, 21 mm
-  18x

Inbus 3x

CrV **1/2"** **1/4"** **59x**

Br. Specifikacija
17214









10 years guarantee

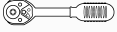

4

FESTA made by **HONITON**

GEDORA KOMPLET

-  1/2" · 72 T
-  1/2" · 125 mm, 250 mm
-  1/2"
-  16 mm, 21 mm
-  1/2"
-  1/2"
-  1/2" · 8-9-10-11-12-13-14-15-16-17-18-19-20-21-22-23-24-27-30-32 mm

CrV **1/2"** **28x**

Br. Specifikacija
17213





10 years guarantee



4

FESTA made by **HONITON**

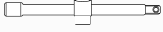
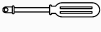
GEDORA KOMPLET

-  1/4" · 72 T
-  1/4" · 50 mm
-  1/4"
-  1/4"
-  1/4" · 4-4,5-5-5,5-6-7-8-9-10-11-12-13 mm

CrV **1/4"** **16x**

Br. Specifikacija
17215



10 years guarantee



1

FESTA made by **HONITON**

GEDORA KOMPLET

- 1/2" · 72 T
- 1/2" · 125 mm, 250 mm
- 1/2"
- 16 mm, 21 mm
- 1/2"
- 1/2" · 10-11-12-13-14-15-16-17-18-19-20-21-22-23-24-27-30-32 mm

CrV 1/2" 25x

Br. Specifikacija
17216



10 years guarantee



10

FESTA made by **HONITON**

GEDORA KOMPLET

- 1/4" · 72 T
- 1/4" · 50 mm
- 1/4"
- 1/4"
- 1/4"
- 1/4" · 4-4,5-5-5,5-6-7-8-9-10-11-12-13 mm
- 12x

Inbus 3x

CrV 1/4" 32x

Br. Specifikacija
17217



10 years guarantee



1

FESTA made by **HONITON**

GEDORA KOMPLET

- 1/2", 1/4" · 72 T
- 1/2", 1/4"
- 1/4" 150 mm
- 1/4" 100 mm
- 1/2", 1/4"
- 1/2" · 125 mm, 250 mm
- 1/4" · 4-4,5-5-5,5-6-7-8-9-10-11-12-13 mm
- 1/2" · 10-11-12-13-14-15-17-19-21-22-24-27-30-32 mm
- 16 mm, 21 mm
- 16x

Inbus 3x

CrV 1/4" 1/2" 56x

Br. Specifikacija
17218



10 years guarantee



4

FESTA made by **HONITON**

GEDORA KOMPLET

- 1/2", 1/4" · 72 T
- 1/2", 1/4"
- 1/4"
- 1/4" · 50 mm, 100 mm
- 1/2", 1/4"
- 1/2", 1/4"
- 1/2" 125 mm, 250 mm
- 1/4" · 4-4,5-5-5,5-6-7-8-9-10-11-12-13-14 mm
- 1/2" · 10-11-12-13-14-15-17-19-21-22-24-27-30-32 mm
- 1/4" · 6-7-8-9-10-11-12-13 mm
- 1/2" · 14-15-17-19-22 mm
- 16 mm, 21 mm
- 34x

Inbus 3x

CrV 1/4" 1/2" 94x

Br. Specifikacija
17219









10 years guarantee

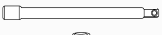
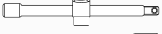

3

FESTA made by **HONITON**

GEDORA KOMPLET

-   1/2" · 72 T
-  1/2" · 125 mm, 250 mm
-  1/2"
-  16 mm, 21 mm
-  1/2"
-  1/2" · 8-9-10-11-12-13-14-15-16-17-18-19-20-21-22-23-24-27-30-32 mm

CrV 1/2" 27x





Br. Specifikacija
17225



4

FESTA made by **HONITON**

GEDORA KOMPLET

-   3/4" · 72 T
-  3/4" · 100 mm, 200 mm
-  3/4" · 460 mm
-  3/4" · 22-24-27-30-32-36-38-41-46-50 mm

CrV 3/4" 14x





Br. Specifikacija
17226



1

FESTA made by **HONITON**

GEDORA KOMPLET

-   3/4" · 72 T
-  3/4" · 100 mm, 200 mm, 400 mm
-  3/4" · 460 mm
-  3/4" · 19-21-22-23-24-26-27-29-30-32-35-36-38-41-46-50 mm

CrV 3/4" 21x

Br. Specifikacija
17227





1



FESTA made by **HONITON**

NASTAVAK GEDORA

-   1/2" HEX · 4-5-6-7-8-10-12-14-17 mm

CrV 1/2" 9x

Br. Specifikacija
17345





1



FESTA made by **HONITON**

NASTAVAK GEDORA

-   T20-T25-T27-T30-T40-T45-T50-T55-T60 mm

CrV 1/2" 9x

Br. Specifikacija
17346



1



FESTA made by **HONITON**

NASTAVAK GEDORA

Cr-Mo **1/2"** **3x**

Br.	Specifikacija	
17336	17 mm	5
17337	19 mm	5
17338	21 mm	5



FESTA made by **HONITON**

NASTAVAK GEDORA

1/2" · 17-19-21 mm

Cr-Mo **1/2"** **3x**

Br.	Specifikacija	
17335		1



FESTA made by **HONITON**

PROFI KRCKALICA CRV

CrV

Br.	Specifikacija	
17220	1/4" 36 zuba	20
17222	3/8" 36 zuba	10
17224	1/2" 36 zuba	6
17208	1/2" 72 zuba	6



NASTAVAK GEDORA DRIVELOCK

4-5-5,5-6-7-8-9-10-11-12-13 mm

CrV **1/4"** **12x**

Br.	Specifikacija	
17250		10



NASTAVAK GEDORA TORX

1/4" · 5-6-7-8-10

1/2" · 12-14-16-18

CrV **1/2"** **1/4"** **9x**

Br.	Specifikacija	
17255		4



FESTA®

10 years guarantee



Cr-Mo

- For use in industry and services
- High quality Chrom Vanadium steel
- Ratchet with 72 teeth for the most precise work
- All components by DIN norm
- Knurled heads for better grip
- Strong case with steel lockers and steel hinges



FESTA

KOMPLET ALATA

- | | |
|--|--|
| 1/2", 1/4" | 1/4" · S 4 · 5.5 · 6.5 |
| 1/4" · 4-5-6-7-8-9mm | 1/4" · PH 1 · 2 · 3 |
| 1/2" · 10-12-13-14-17-19mm | 1/4" · PZ 2 · 3 |
| 1/4" · 4-4.5-5-5.5-6-7-8-9-10-11-12-13-14mm | 1/4" · H 3 · 4 · 5 · 6 |
| 1/2" · 12-13-14-15-16-17-18-19-20-21-22-24mm | 1/4" · T 8 · 10 · 15 · 20 · 25 |
| 1/2", 1/4" | 1/4" · TTa 10 · 15 · 20 · 25 · 40 |
| 1/4" · 4-4.5-5-5.5-6-7-8-9-10-11-12-13-14mm | 2 · 2.5 · 3 · 4 · 5 · 6 · 7 · 8 · 10mm |
| 1/2" · 12-13-14-15-16-17-18-19-20-21-22-24mm | 8-9-10-11-12-13-14-15-16-17-18-19mm |
| 1/2", 1/4" | S 4x100 · 6.5x150 |
| 1/4" · 4-4.5-5-5.5-6-7-8-9-10-11-12-13-14mm | PH 2x100 · 3x150 |
| 1/2" · 12-13-14-15-16-17-18-19-20-21-22-24mm | 180mm |
| 1/2", 1/4" | 160mm |
| 1/2" · 16-21mm | 160mm |
| 1/4" · 150mm | 250mm |
| 1/2" · E10-E12-E14-E16-E18-E20-E22-E24 | 300g |
| 1/4" · S 3 · 4 · 5 · 6 | |
| 1/4" · PH 0 · 1 · 2 | |
| 1/4" · PZ 0 · 1 · 2 | |



Br. 17238 Specifikacija 122 kom



1



FESTA

GEDORA KOMPLET

- 1/2" · 72T
- 1/2" · 125 mm
- 1/2" · 10-11-12-13-14-15-17-19-22-24 mm



Br. 17245 Specifikacija 15



15



FESTA

GEDORA KOMPLET

- 1/2" · 72T
- 1/2" · 125 mm
- 1/2" · 10-11-12-13-14-15-17-19-22-24 mm



Br. 17229 Specifikacija 15



8

FESTA

GEDORA KOMPLET

- 1/2" · 72 T
- 1/2" · 75, 125 mm
- 1/2"
- 1/2" · 10-11-12-13-14-15-16-17-18-19-22-24 mm
- 1/2" · 17mm, 19mm
- 3 way adapter
- 16mm, 21mm



Br. Specifikacija

17230



4

FESTA

GEDORA KOMPLET

- 1/4" · 72 T
- 1/4" · 50, 100 mm
- 1/4"
- 1/4" · 4-5-5,5-6-7-8-10-11-12-13 mm
- 1/4" · 6-7-8-10-12-13 mm
- 3 way adapter
- 4 x
- 11x
- 1x



Br. Specifikacija

17231



10

FESTA

GEDORA KOMPLET

- 1/4"
- 1/4"
- 1/4" · 4-4,5-5-5,5-6-7-8-9-10-11-12-13-14 mm
- 1/4" · 50 mm, 100 mm
- 1/4"
- 1/4"
- 21 x
- 1/4"
- L 1/4"

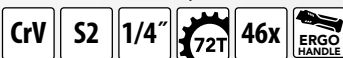

Br. Specifikacija

17233



10

FESTA

GEDORA KOMPLET

- 1/2", 1/4" · 72T
- 1/4"
- 16 mm, 21 mm
- 1/4" · 10-11-12-13-14-15-16-17-18-19-20-21-22-23-24-27 mm
- 1/4" · 100 mm
- 1/2" · 125 mm, 250 mm
- 1/4"
- 1 x
- 1/4" · 4-5-5,5-6-7-8-10-11-12-13 mm
- 33 x

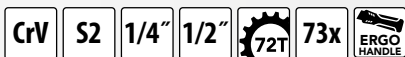

Br. Specifikacija











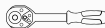
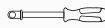



17234

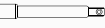

4

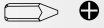
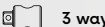
FESTA

GEDORA KOMPLET

-  1/2", 1/4" · 72T
-  1/4"
-  16 mm, 21 mm
-  1/4" · 4 -4,5-5-5,5-6-7-8-9-10-11-12-13-14 mm
-  1/2" · 10-11-12-13-14-15-16-17-18-19-20-21-22-23-24-27-30-32 mm
-  1/4" · 6-7-8-9-10-11-12-13 mm
-  1/2" · 14-15-17-19 mm
-  1/4" · 50 mm, 100 mm
-  1/2" · 125 mm, 250 mm
-  1/4"
-  5/16" bit holder
-  17x
-  15x
-  3 way adapter
-  3 x
-  1/4"
-  L 1/4"
-  1/2", 1/4"

CrV S2 1/4" 1/2" 72T 94x ERGO HANDLE



10 years guarantee













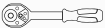
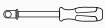

Br. Specifikacija

17235

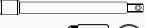
4

FESTA

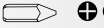
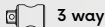
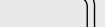
GEDORA KOMPLET

-  1/2", 1/4" · 72T
-  150 mm
-  16 mm, 21 mm
-  1/4" · 4 -4,5-5-5,5-6-7-8-9-10-11-12-13-14 mm
-  1/2" · 10-11-12-13-14-15-16-17-18-19-20-21-22-24-27-30-32 mm
-  1/4" · 6-7-8-9-10-11-12-13 mm
-  1/2" · 14-15-17-19-22 mm
-  1/4" · 50 mm, 100 mm
-  1/2" · 125 mm, 250 mm
-  E · 4-5-6-7-8-10-11-12-14-16-18-20-24-27-30-32 mm
-  1/2", 1/4"
-  5/16" bit holder
-  18 x
-  17 x
-  3 way adapter
-  4 x
-  1/4"
-  L 1/4"

CrV S2 1/4" 1/2" 72T 110x ERGO HANDLE



10 years guarantee













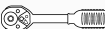







Br. Specifikacija

17236

4

FESTA

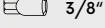
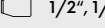
GEDORA KOMPLET

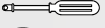
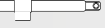
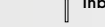
-  1/2", 1/4", 3/8"
-  1/4" · 4-5-6-7-8-9-10mm
-  3/8" · 10-11-12-13-14-15mm
-  1/2" · 16-17-18-19-22mm
-  1/4" · 4-4,5-5-5,5-6-7-8-9-10-11-12-13-14mm
-  3/8" · 10-11-12-13-14-15-16-17-18-19mm
-  1/2" · 10-11-12-13-14-15-16-17-18-19-20-21-22-24-27-30-32mm
-  1/4" · E4-E5-E6-E7-E8
-  3/8" · E10-E11-E12-E14-E16-E18
-  1/2" · E20-E24
-  1/2" · 24x
-  1/4" · 20x
-  1/4" · 30x
-  1/4" · 50 mm, 100 mm
-  1/2" · 125 mm, 250 mm
-  3/8" · 150 mm
-  1/2" · 16-21mm
-  3/8" · 18mm
-  1/2", 1/4", 3/8" bit holder
-  1/2", 1/4", 3/8"
-  1/4" · 150mm
-  1/4" · 115mm
-  Inbus 7X

CrV S2 1/4" 1/2" 3/8" 72T 171x ERGO HANDLE



10 years guarantee



Br. Specifikacija

17237

2

FESTA®

RATCHET FESTA

- Ratchet is made from the best quality ChromVanadium steel
- Ratchet with 72 teeth for most precise work
- Quality ergonomic, two-component handle made of softened TPE rubber
- SYSTEM QUICK RELEASE for quick and easy changing of socket heads

FESTA®
PROFI KRCKALICA CRV

Br.	Specifikacija		
17297	1/4"	155 mm	6
17298	3/8"	210 mm	5
17299	1/2"	255 mm	4

FESTA®
PROFI KRCKALICA CRV

Br.	Specifikacija		
17240	1/4"	155 mm	10
17241	3/8"	200 mm	10
17242	1/2"	250 mm	5

FESTA®
PROFI KRCKALICA CRV



Br.	Specifikacija		
17294	1/4"	155 mm	6
17295	3/8"	205 mm	10
17296	1/2"	255 mm	4

FESTA®
KRCKALICA 1/4"

Br.	Specifikacija		
17292	1/4"		1

KRCKALICA

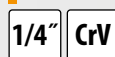
Br.	Specifikacija		
17243	1/4"		25
17244	1/2"		25

FESTA®
NASTAVAK ZA GEDORE

Br.	Specifikacija		
18603	1/4" 150 mm		10

NEW



NASTAVAK GEDORA UNIVERZALNI



Br.	Specifikacija	
17812	10 - 19 mm	1



FESTA

NASTAVAK GEDORA 1/4"



Br.	Specifikacija	
17860	4 mm • 50 mm	10
17861	5 mm • 50 mm	10
17862	6 mm • 50 mm	10
17863	7 mm • 50 mm	10
17864	8 mm • 50 mm	10
17865	9 mm • 50 mm	10

Br.	Specifikacija	
17866	10 mm • 50 mm	10
17867	11 mm • 50 mm	10
17868	12 mm • 50 mm	10
17869	13 mm • 50 mm	10
17870	14 mm • 50 mm	10



FESTA

NASTAVAK GEDORA 1/2"



Br.	Specifikacija	
17871	10 mm • 70 mm	10
17872	11 mm • 70 mm	10
17873	12 mm • 70 mm	10
17874	13 mm • 70 mm	10
17875	14 mm • 70 mm	10
17876	15 mm • 70 mm	10
17877	16 mm • 70 mm	10
17878	17 mm • 70 mm	10
17879	18 mm • 70 mm	10
17880	19 mm • 70 mm	10
17881	20 mm • 70 mm	10

Br.	Specifikacija	
17882	21 mm • 70 mm	10
17883	22 mm • 70 mm	10
17884	23 mm • 70 mm	10
17885	24 mm • 70 mm	10
17886	25 mm • 70 mm	10
17887	26 mm • 70 mm	10
17888	27 mm • 70 mm	10
17889	28 mm • 70 mm	10
17890	30 mm • 70 mm	10
17891	32 mm • 70 mm	10
17892	34 mm • 70 mm	10



NASTAVAK GEDORA UNIVERZALNI



Br.	Specifikacija	
17810	Za vijke 7 - 19 mm • 52 mm x ø26 mm	1



NASTAVAK GEDORA UNIVERZALNI



Br.	Specifikacija	
17811	Za vijke 11 - 32 mm • 83 mm x ø43 mm	5

FESTA

NASTAVAK GEDORA 1/4"



Br.	Specifikacija	
17820	4 mm • 25 mm	10
17821	4,5 mm • 25 mm	10
17822	5 mm • 25 mm	10
17823	5,5 mm • 25 mm	10
17824	6 mm • 25 mm	10
17825	7 mm • 25 mm	10
17826	8 mm • 25 mm	10

Br.	Specifikacija	
17827	9 mm • 25 mm	10
17828	10 mm • 25 mm	10
17829	11 mm • 25 mm	10
17830	12 mm • 25 mm	10
17831	13 mm • 25 mm	10
17832	14 mm • 25 mm	10



FESTA

NASTAVAK GEDORA 1/2"



Br.	Specifikacija	
17308	8 mm • 38 mm	10
17309	9 mm • 38 mm	10
17310	10 mm • 38 mm	10
17311	11 mm • 38 mm	10
17312	12 mm • 38 mm	10
17313	13 mm • 38 mm	10
17314	14 mm • 38 mm	10
17315	15 mm • 38 mm	10
17316	16 mm • 38 mm	10
17317	17 mm • 38 mm	10
17318	18 mm • 38 mm	10

Br.	Specifikacija	
17319	19 mm • 38 mm	10
17320	20 mm • 38 mm	10
17321	21 mm • 38 mm	10
17322	22 mm • 38 mm	10
17324	24 mm • 38 mm	10
17327	27 mm • 42 mm	20
17330	30 mm • 42 mm	25
17332	32 mm • 42 mm	20
17333	34 mm • 42 mm	20
17334	36 mm • 42 mm	20



**FESTA**

NASTAVAK GEDORA 3/4"

CrV 3/4"



Br.	Specifikacija		Br.	Specifikacija	
17835	17 mm · 48 mm	10	17846	33 mm · 55 mm	10
17836	18 mm · 48 mm	10	17847	36 mm · 60 mm	10
17837	19 mm · 48 mm	10	17848	38 mm · 60 mm	10
17838	21 mm · 48 mm	10	17849	41 mm · 65 mm	10
17839	22 mm · 48 mm	10	17850	46 mm · 65 mm	10
17840	24 mm · 48 mm	10	17851	50 mm · 70 mm	10
17841	26 mm · 48 mm	10	17852	55 mm · 75 mm	10
17842	27 mm · 52 mm	10	17853	60 mm · 78 mm	10
17843	28 mm · 52 mm	10	17854	65 mm · 82 mm	10
17844	30 mm · 52 mm	10	17855	70 mm · 82 mm	10
17845	32 mm · 52 mm	10	17856	75 mm · 88 mm	10

**FESTA**

NASTAVAK GEDORA MULTILOCK 1/4"

CrV 1/4"



Br.	Specifikacija		Br.	Specifikacija	
17895	4 mm · 25 mm	10	17902	9 mm · 25 mm	10
17896	4,5 mm · 25 mm	10	17904	11 mm · 25 mm	10
17897	5 mm · 25 mm	10	17905	12 mm · 25 mm	10
17898	5,5 mm · 25 mm	10	17907	14 mm · 25 mm	10

**FESTA**

NASTAVAK GEDORA MULTILOCK 1/2"

CrV 1/2"



Br.	Specifikacija		Br.	Specifikacija	
17910	8 mm · 38 mm	10	17922	21 mm · 38 mm	10
17912	10 mm · 38 mm	10	17924	24 mm · 38 mm	10
17913	11 mm · 38 mm	10	17925	27 mm · 38 mm	10
17914	12 mm · 38 mm	10	17926	30 mm · 38 mm	10
17916	14 mm · 38 mm	10	17927	32 mm · 38 mm	10

**FESTA**

NASTAVAK GEDORA TORX 1/4"

CrV 1/4"



Br.	Specifikacija		Br.	Specifikacija	
17930	E4	10	17933	E7	10
17931	E5	10	17934	E8	10
17932	E6	10	17935	E10	10

**FESTA**

NASTAVAK GEDORA TORX 1/2"

CrV 1/2"



Br.	Specifikacija	
17943	E22	10
17944	E24	10



FESTA

NASTAVAK GEDORA 1/4"

CrV S2 1/4"



Br.	Specifikacija	
18920	S 4 mm	10
18921	S 5,5 mm	10
18922	S 7 mm	10



FESTA

NASTAVAK GEDORA 1/4"

CrV S2 1/4"



Br.	Specifikacija	
18925	PH 1	10
18926	PH 2	10
18927	PH 3	10



FESTA

NASTAVAK GEDORA 1/4"

CrV S2 1/4"



Br.	Specifikacija	
18928	PZ 0	10
18929	PZ 1	10
18930	PZ 2	10
18931	PZ 3	10



FESTA

NASTAVAK GEDORA 1/2"

CrV S2 1/2"



Br.	Specifikacija	
18971	M 16	10



FESTA

NASTAVAK GEDORA 1/4"

CrV S2 1/4"



Br.	Specifikacija	
18934	3 mm	10
18937	6 mm	10
18939	8 mm	10



FESTA

NASTAVAK GEDORA 1/2"

CrV S2 1/2"



Br.	Specifikacija	
18944	12 mm	10
18945	14 mm	10



FESTA

NASTAVAK GEDORA 1/4"

CrV S2 1/4"



Br.	Specifikacija	
18948	T 5	10
18950	T 8	10
18951	T 10	10



FESTA

NASTAVAK GEDORA 1/2"

CrV S2 1/2"



Br.	Specifikacija		Br.	Specifikacija	
18954	T 10	10	18960	T 40	10
18955	T 15	10	18961	T 45	10
18956	T 20	10	18963	T 55	10
18957	T 25	10			

FESTA
 ADAPTER

CrV



Br.	Specifikacija		
17410	A - 1/4"	B - 3/8"	10
17411	A - 3/8"	B - 1/4"	10
17412	A - 3/8"	B - 1/2"	10
17413	A - 1/2"	B - 3/8"	10

Br.	Specifikacija		
17414	A - 1/2"	B - 3/4"	10
17415	A - 3/4"	B - 1/2"	10
17416	A - 1/4"	B - 1/2"	10

FESTA

NASTAVAK GEDORE ZGLOBNI

CrV



Br.	Specifikacija	
17405	1/4" · 39 mm	10
17406	1/2" · 71 mm	10
17407	3/4" · 105 mm	10

FESTA

KLIZEĆI NASTAVAK ZA GEDORU

CrV



Br.	Specifikacija	
17420	1/4"	1
17421	1/2"	1
17422	3/4"	1

FESTA

„T” NASTAVAK KLIZEĆI ZA GEDORU

CrV



Br.	Specifikacija	
17382	1/4" · 115 mm	1
17383	3/8" · 190 mm	1
17384	1/2" · 250 mm	1
17385	3/4" · 460 mm	1
17386	1" · 640 mm	1

FESTA

„T” NASTAVAK ZA GEDORU SA KOLENOM

CrV



Br.	Specifikacija	
17401	1/4" · 250 mm	1
17402	1/2" · 400 mm	1

FESTA

OKRETNNA RUČKA ZA GEDORU

CrV



Br.	Specifikacija	
17380	1/2" · 350 mm	1
17381	3/4" · 500 mm	1

FESTA

L RUČICA ZA GEDORU

CrV 1/2"



Br.	Specifikacija	
17427	1/2" · 60 x 320 mm	1



FESTA

PRODUŽNI NASTAVAK ZA GEDORU

CrV

Br.	Specifikacija	
17390	1/4" · 50 mm	1
17391	1/4" · 100 mm	1
17392	1/4" · 150 mm	1
17393	1/2" · 75 mm	1
17394	1/2" · 125 mm	1



FESTA

FLEKOMIBILNI NASTAVAK ZA GEDORU

CrV 1/4"

Br.	Specifikacija	
17400	1/4" · 150 mm	1



Stahlberg

ADAPTER KRCKALICA 1/4" - BIT

CrV

1/4" ↔ 1/4"



Br.	Specifikacija	
18619		5



KOMPLET ADAPTERA ZA BUŠILICU

CrV 1/4" 3x



Br.	Specifikacija	
18604	1/4", 3/8", 1/2"	10



KLJUČ ZA ODZRAČIVANJE RADIJATORA SA KONTEJNEROM



Br.	Specifikacija	
17459	50 ml	1

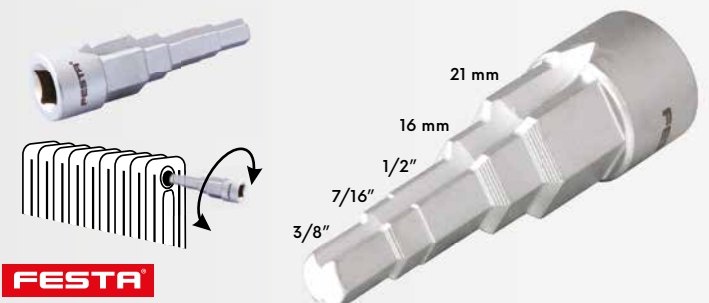

FESTA

UNIVERZALNI KLJUČ ZA RADIJATORE

CrV 1/2"



Br.	Specifikacija	
17455		10



FESTA

UNIVERZALNI KLJUČ ZA RAZVODNE ORMARE

1,0 x 7 mm
 PH2



Br.	Specifikacija	
17458		1



FESTA

UNIVERZALNI KLJUČ ZA RAZVODNE ORMARE

D 11-12 A 7-8 A 6-7 D 3-5
 1,0 x 7 mm
 PH2

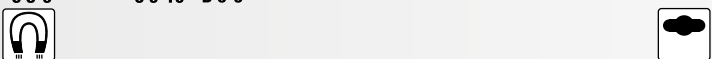

Br.	Specifikacija	
17456		50

FESTA®

- Forged keys made of CrV grade steel
- Made according to DIN standards
- Chrome coating

FESTA®
KLJUČEVI VILJUŠKASTI
CrV DIN 3110

Br.	Specifikacija	
17550	6 x 7 mm	10
17551	8 x 9 mm	10
17552	8 x 10 mm	10
17553	10 x 11 mm	10
17590	10 x 13 mm	10
17554	12 x 13 mm	10
17555	14 x 15 mm	10
17556	13 x 16 mm	10
17557	13 x 17 mm	10
17591	14 x 17 mm	10
17558	16 x 17 mm	10
17559	17 x 19 mm	10
17560	18 x 19 mm	10

Br.	Specifikacija	
17592	19 x 22 mm	10
17593	19 x 24 mm	10
17561	20 x 22 mm	10
17569	21 x 23 mm	10
17548	22 x 24 mm	10
17562	24 x 27 mm	10
17549	24 x 30 mm	10
17563	30 x 32 mm	10
17564	30 x 34 mm	10
17565	32 x 36 mm	10
17566	36 x 41 mm	10
17567	46 x 50 mm	10
17568	50 x 55 mm	3

FESTA®
KLJUČEVI VILJUŠKASTI
CrV DIN 3113

Br.	Specifikacija	
17487	6 mm	10
17570	7 mm	10
17571	8 mm	10
17572	9 mm	10
17573	10 mm	10
17574	11 mm	10
17575	12 mm	10
17576	13 mm	10
17577	14 mm	10
17578	15 mm	10
17579	16 mm	10
17580	17 mm	10
17581	18 mm	10
17582	19 mm	10
17488	20 mm	10

Br.	Specifikacija	
17489	21 mm	10
17583	22 mm	10
17490	23 mm	10
17584	24 mm	10
17491	25 mm	10
17492	26 mm	10
17585	27 mm	10
17493	28 mm	10
17494	29 mm	10
17586	30 mm	10
17587	32 mm	10
17495	33 mm	10
17496	34 mm	10
17589	36 mm	10

FESTA®
KLJUČEVI SA GEDOROM ZGLOBNI
CrV 72T

Br.	Specifikacija	
17628	8 mm	10
17622	10 mm	10
17623	13 mm	10
17624	14 mm	10
17629	15 mm	10
17630	16 mm	5

Br.	Specifikacija	
17625	17 mm	10
17631	18 mm	10
17626	19 mm	10
17632	21 mm	5
17633	22 mm	5

FESTA®
KLJUČEVI SA GEDOROM
CrV 72T

Br.	Specifikacija	
17660	6 mm	10
17676	7 mm	10
17661	8 mm	10
17662	9 mm	10
17663	10 mm	10
17664	11 mm	10
17665	12 mm	10
17666	13 mm	10
17667	14 mm	10
17668	15 mm	10

Br.	Specifikacija	
17669	16 mm	10
17670	17 mm	10
17671	18 mm	10
17672	19 mm	10
17674	21 mm	5
17675	22 mm	5
17677	24 mm	5
17678	27 mm	5
17679	30 mm	5
17683	32 mm	5





FESTA
KLJUČEVI OKASTI

CrV **DIN 838**

Br.	Specifikacija	
17605	6 x 7 mm	10
17606	8 x 9 mm	10
17607	8 x 10 mm	10
17608	10 x 11 mm	10
17609	12 x 13 mm	10
17611	13 x 16 mm	10
17612	13 x 17 mm	10

Br.	Specifikacija	
17610	14 x 15 mm	10
17613	16 x 17 mm	10
17614	18 x 19 mm	10
17615	20 x 22 mm	10
17616	24 x 27 mm	10
17617	30 x 32 mm	10



FESTA
KLJUČEVI VILJUŠKASTI
DIN 895



Br.	Specifikacija	
17460	6 x 7 mm	10
17461	8 x 9 mm	10
17462	8 x 10 mm	10
17463	10 x 11 mm	10
17481	10 x 13 mm	10
17464	12 x 13 mm	10
17465	14 x 15 mm	10
17466	13 x 16 mm	10
17467	13 x 17 mm	10
17482	14 x 17 mm	10
17468	16 x 17 mm	10

Br.	Specifikacija	
17469	17 x 19 mm	10
17470	18 x 19 mm	10
17483	19 x 22 mm	10
17484	19 x 24 mm	10
17471	20 x 22 mm	10
17472	24 x 27 mm	10
17486	21 x 23 mm	10
17480	28 x 30 mm	10
17473	30 x 32 mm	10
17485	36 x 41 mm	10



FESTA
KLJUČEVI VILJUŠKASTI

CrV **DIN 3110**

Br.	Specifikacija	
17761	14 x 15 mm	10
17769	20 x 22 mm	10



FESTA
KLJUČEVI VILJUŠKASTI

CrV **DIN 3113**

Br.	Specifikacija	
17788	14 mm	10
17789	15 mm	10
17795	21 mm	10
17806	33 mm	10



12-13-14-15 mm

16-17-18-19 mm

KLJUČ

Cr-Mo

Br.	Specifikacija	
17685	12-13-14-15-16-17-18-19 mm	1



FESTA
ŠTELUJUĆI KLJUČ

CrV

Br.	rozsah	délka	
17197	0 - 29 mm	200 mm	1
17198	0 - 33 mm	250 mm	1
17199	0 - 38 mm	300 mm	1



ŠTELUJUĆI KLJUČ

Br.	rozsah	délka	
17200	0 - 24 mm	200 mm	6
17201	0 - 30 mm	250 mm	6
17202	0 - 34 mm	300 mm	6



**FESTA**

KLJUČEVI VILJUŠKASTI KOMPLET

CrV

DIN 3110



Br.	Specifikacija	
17506	6 kom · 6 x 7, 8 x 9, 10 x 11, 12 x 13, 14 x 15, 16 x 17	1
17508	8 kom · 6 x 7, 8 x 9, 10 x 11, 12 x 13, 14 x 15, 16 x 17, 18 x 19, 20 x 22	1

**FESTA**

KLJUČEVI KOMBINOVANI KOMPLET

CrV

DIN 3113



Br.	Specifikacija	
17526	6 kom · 10 x 10, 11 x 11, 13 x 13, 14 x 14, 16 x 16, 17 x 17	1
17528	8 kom · 8 x 8, 10 x 10, 11 x 11, 13 x 13, 14 x 14, 16 x 16, 17 x 17, 19 x 19	1

**FESTA**

KLJUČEVI OKASTI KOMPLET

CrV

DIN 838

8x



Br.	Specifikacija	
17539	6 x 7, 8 x 9, 10 x 11, 12 x 13, 14 x 15, 16 x 17, 18 x 19, 20 x 22	1

**FESTA**

KLJUČEVI VILJUŠKASTI KOMPLET

CrV DIN 3110

12x



Br.	Specifikacija	
17512	6 x 7, 8 x 9, 10 x 11, 12 x 13, 14 x 15, 16 x 17, 18 x 19, 20 x 22, 21 x 23, 24 x 27, 25 x 28, 30 x 32	1

**FESTA**

KLJUČEVI KOMBINOVANI KOMPLET

CrV

DIN 3113



Br.	Specifikacija	
17532	12 kom · 8 x 8, 9 x 9, 10 x 10, 11 x 11, 13 x 13, 14 x 14, 16 x 16, 17 x 17, 18 x 18, 19 x 19, 21 x 21, 22 x 22	10
17533	18 kom · 6 x 6, 7 x 7, 8 x 8, 9 x 9, 10 x 10, 11 x 11, 12 x 12, 13 x 13, 14 x 14, 15 x 15, 16 x 16, 17 x 17, 18 x 18, 19 x 19, 20 x 20, 21 x 21, 22 x 22, 24 x 24	1
17534	25 kom · 6 x 6, 7 x 7, 8 x 8, 9 x 9, 10 x 10, 11 x 11, 12 x 12, 13 x 13, 14 x 14, 15 x 15, 16 x 16, 17 x 17, 18 x 18, 19 x 19, 20 x 20, 21 x 21, 22 x 22, 23 x 23, 24 x 24, 25 x 25, 26 x 26, 27 x 27, 28 x 28, 30 x 30, 32 x 32	4

**FESTA**

KLJUČEVI VILJUŠKASTI KOMPLET

DIN 895



Br.	Specifikacija	
17475	8 kom · 6 x 7, 8 x 9, 10 x 11, 12 x 13, 14 x 15, 16 x 17, 18 x 19, 20 x 22	5
17476	12 kom · 6 x 7, 8 x 9, 10 x 11, 12 x 13, 14 x 15, 16 x 17, 18 x 19, 20 x 22, 21 x 23, 24 x 27, 28 x 30, 30 x 32	3



FESTA

KLJUČ SA GEDOROM KOMPLET

CrV 72T 7x

Br.	Specifikacija	
17620	8, 10, 12, 13, 14, 17, 19	5



FESTA

KLJUČ SA GEDOROM ZGLOBNI - KOMPLET

CrV 72T 7x

Br.	Specifikacija	
17621	10, 12, 13, 14, 15, 17, 19	5



FESTA

KLJUČEVI CEVASTI KOMPLET

CrV 7x



Br.	Specifikacija	
17501	6 x 7, 8 x 9, 10 x 11, 12 x 13, 14 x 15, 16 x 17, 18 x 19	20
17640	Ručica za cevasti ključ · 135 mm	50



FESTA

KLJUČ KUKA

CrV



Br.	Specifikacija	
17680	19 - 51 mm 165 mm	5
17681	32 - 76 mm 216 mm	5
17682	51 - 121 mm 267 mm	5

FESTA

CIJEVASTI KLJUČ

CrV



Br.	Specifikacija		Br.	Specifikacija	
17650	6 x 7 mm	10	17655	16 x 17 mm	10
17651	8 x 9 mm	10	17645	16 x 18 mm	10
17642	8 x 10 mm	10	17653	16 x 21 mm	10
17652	10 x 11 mm	10	17656	18 x 19 mm	10
17643	12 x 13 mm	10	17657	19 x 22 mm	10
17654	14 x 15 mm	10	17659	22 x 24 mm	10
17644	14 x 17 mm	10	17658	24 x 27 mm	10



KLJUČ ZA UGAONE BRUSILICE



Br.	Specifikacija	
20967	200 mm	15

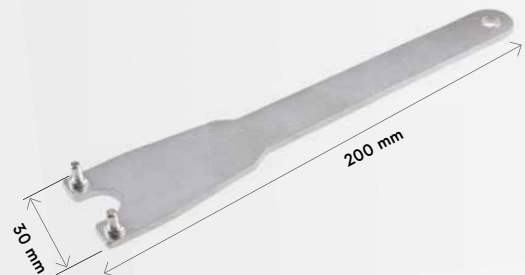

KLJUČ ZA UGAONE BRUSILICE



Br.	Specifikacija	
20968	200 mm	1

**FESTA**

KILO KLJUČ

Br.	Specifikacija	
17203	1/4" 5 - 25 Nm	1
17204	1/2" 19 - 110 Nm	1
17205	1/2" 42 - 210 Nm	1
17206	3/4" 140 - 700 Nm	1

**FESTA**

KLJUČ SA GEDOROM

Br.	Specifikacija	
17451	18 mm	10
17450	19 mm	10



KLJUČ ZA TOČKOVE



Br.	Specifikacija	
17600	17, 19, 22 mm, 13/16"	16

KLJUČ ZA TOČKOVE



Br.	Specifikacija	
17601	17, 19, 21 mm	20



TELESKOP KLJUČ ZA TOČKOVE



1/2"

3x



Br.	Specifikacija	
17603	17 x 19 mm, 21 x 23 mm	20



CEVASTI KLJUČ T ZGLOBNI SA NASTAVKOM



Br.	Specifikacija	
17261	16 mm	1
17262	21 mm	1



FESTA

MAGNETNI DRZAČ



Br. Specifikacija

70098



12

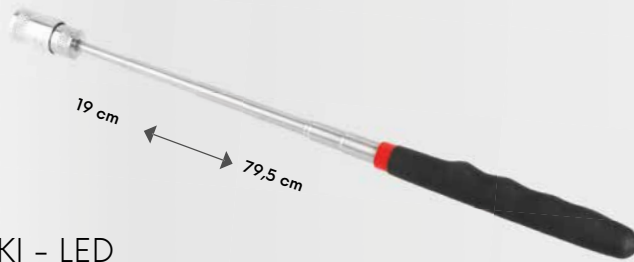

FESTA

MAGNET TELESKOPSKI - LED



Br. Specifikacija

13294



6

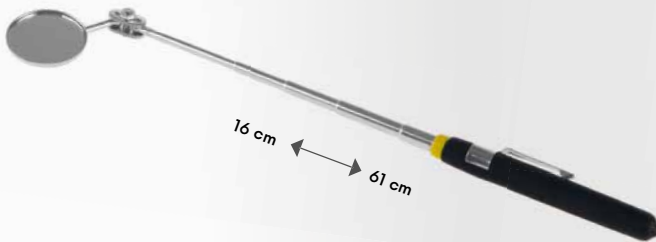

MAJSTORSKO OGLEDALO



Br. Specifikacija

13290



20

Br. Specifikacija

13293



20

MAGNET TELESKOPSKI

FESTA®

- Shaft made of quality S2 steel
- Magnetic ending
- Ergonomic two-component with softened TPE rubber



FESTA®

ODVIJAČ PLJOSNATI



Br.	Specifikacija	
18113	3 x 75 mm	12
18114	4 x 100 mm	12
18115	5,5 x 125 mm	12
18116	6,5 x 150 mm	12
18118	8 x 175 mm	6
18120	10 x 200 mm	6



FESTA®

ODVIJAČ PLJOSNATI KRATKI

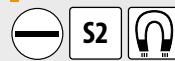

Br.	Specifikacija	
18124	5,5 x 38 mm	12
18125	6,5 x 38 mm	12



FESTA®

ODVIJAČ PHILIPS



Br.	Specifikacija	
18210	0 x 75 mm	12
18211	1 x 75 mm	12
18212	2 x 100 mm	12



FESTA®

ODVIJAČ PHILIPS KRATKI

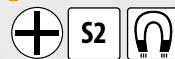

Br.	Specifikacija	
18215	1 x 38 mm	12
18216	2 x 38 mm	12



FESTA®

ODVIJAČ POZIDRIVE



Br.	Specifikacija	
18310	0 x 75 mm	12
18311	1 x 100 mm	12
18312	2 x 100 mm	12
18313	3 x 150 mm	6



FESTA®

ODVIJAČ POZIDRIVE KRATKI

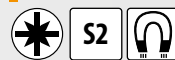

Br.	Specifikacija	
18321	1 x 38 mm	12
18322	2 x 38 mm	12



FESTA

ODVIJAČ TORX



Br.	Specifikacija	
18350	T6	12
18351	T7	12
18352	T8	12
18353	T9	12
18354	T10	12
18355	T15	12

Br.	Specifikacija	
18356	T20	12
18357	T25	12
18358	T27	12
18359	T30	12
18360	T40	6



FESTA

ODVIJAČ SA UDUBLJENJEM



Br.	Specifikacija	
18455	6 mm	12
18456	7 mm	12
18460	13 mm	12



FESTA

ODVIJAČ UDARNI PLJOSNATI



Br.	Specifikacija	
18062	5,5 x 100 mm	12
18063	7 x 125 mm	6
18064	8 x 150 mm	8

Br.	Specifikacija	
18065	10 x 175 mm	6
18066	10 x 200 mm	6
18067	10 x 250 mm	6



FESTA

ELEKTRO VDE ODVIJAČ PLJOSNATI



Br.	Specifikacija	
18088	3 x 75 mm S2	12
18089	4 x 100 mm CrV	12
18090	5,5 x 125 mm CrV	12
18091	6,5 x 150 mm CrV	12
18092	8 x 175 mm CrV	12



FESTA

ODVIJAČ UDARNI PHILIPS



Br.	Specifikacija	
18070	PH 1 x 80 mm	8
18071	PH 2 x 100 mm	12
18072	PH 3 x 150 mm	6



FESTA

ELEKTRO VDE ODVIJAČ PHILIPS



Br.	Specifikacija	
18080	PH 0 x 60 mm S2	12
18081	PH 1 x 80 mm CrV	12
18082	PH 2 x 100 mm CrV	12
18083	PH 3 x 150 mm CrV	12



FESTA

ODVIJAČ UDARNI POZIDRIVE



Br.	Specifikacija	
18075	PZ 1 x 80 mm	12
18076	PZ 2 x 100 mm	12
18077	PZ 3 x 150 mm	6



FESTA

ELEKTRO VDE ODVIJAČ POZIDRIVE



Br.	Specifikacija	
18084	PZ 0 x 60 mm S2	12
18085	PZ 1 x 80 mm CrV	12
18086	PZ 2 x 100 mm CrV	12
18087	PZ 3 x 150 mm CrV	12

**FESTA****ODVIJAČ KOMPLET**

S 3x75 · 5x100 · 6x175mm

PH 0 · 1 · 2 · 3



Br.

Specifikacija

18402

6

**FESTA****KOMPLET ODVIJAČA I BITOVA**

S 3 x 75 · 4x100 · 5,5x125 · 6,5 x 150mm

PH 1 x 100 · 2 x 100mm

adapter 1/4"

Bity | Битов S 4 · 5 · 6 · 7

PH 1 · 2 · 3

PZ 1 · 2 · 3

T 10 · 15 · 20 · 25 · 30

H 2 · 3 · 4 · 5 · 6



Br.

Specifikacija

18422

27 kom

6

**FESTA****ODVIJAČ KOMPLET**

S 3x75 · 5x100 · 6x150mm

PH 0 · 1 · 2



Br.

Specifikacija

18403

6

**FESTA****ODVIJAČ KOMPLET**

S 3x60 · 6x100 · 6x125mm

PZ 0 · 1 · 2



Br.

Specifikacija

18404

6

**FESTA****ODVIJAČ KOMPLET TORX**

T 10 · 15 · 20 · 25 · 30



Br.

Specifikacija

18340

6

FESTA**ODVIJAČ KOMPLET**S 6x38 · 5x75 · 6x100 · 8x150mm
2,5x50 · S 3x50mmPH 2x38 · 1x75 · 2x100 · 3x150mm
0x50 · 00x50mm

T 5x50 · 6x50 · 7x50 · 8x50 · 9x50 · 10x50mm



Br.

Specifikacija

18424

18x

6

**FESTA****ODVIJAČ UDARNI KOMPLET**

⊖ S 5 · 6 · 8 mm

⊕ PH 1 · 2 · 3

CrV **6x**Br. Specifikacija
18423

10

**FESTA****ODVIJAČ ELEKTRIČARSKI KOMPLET**

⊖ S 4x100 · 5,5x125 mm · ispitivač napona 0 - 250 V

⊕ PH 0x60 · 1x80 · 2x100 mm

⊖ ⊕ **6x** 1000 V
IEC/EN60900Br. Specifikacija
18413

6

**FESTA****ODVIJAČ UDARNI + 4 UMETKA**

⊖ S 7 x 35 · 8 x 35 · 8 x 70 mm

⊕ PH 2 x 35 · 3 x 35 · 3 x 70 mm

CrV **6x**Br. Specifikacija
18411

1

**FESTA****ODVIJAČ ELEKTRIČARSKI KOMPLET**

⊖ S 4x100 · 5,5x125 · 6,5x150 mm · ispitivač napona 0 - 250 V

⊕ PH 0x75 · 1x100 · 2x100 mm

⊖ ⊕ **7x** 1000 V
IEC/EN60900:2004Br. Specifikacija
18410

40

**FESTA****OTVARAČ ZA FLAŠE**Br. Specifikacija
18437

5

**ISPITIVAČ NAPONA**DIN VDE 0680
73/23 EEC

⊖

Br. Specifikacija
18426 0 - 250 V

1



ODVIJAČ PLJOSNATI



Br.	Specifikacija	
18101	4 x 75 mm	10
18102	4 x 100 mm	10
18103	5,5 x 100 mm	10
18104	5,5 x 125 mm	10
18105	6,5 x 100 mm	10
18106	6,5 x 125 mm	10
18107	8 x 160 mm	10
18108	10 x 160 mm	10



KOMPLET ODVIJAČA I BITOVA

⊖ S 3x75 · 4x75 · 6x100 · 8x150 mm

⊕ PH 1x75 · 2x100 mm

⊙ Adapter 1/4"

Bity: ⊖ S 4 · 5 · 6 · 7 mm

⊕ PH 1 · 2 · 3

⊕ PZ 1 · 2 · 3

⊕ T 10 · 15 · 20

⊙ ↔ ⊙ adapter



Br.	Specifikacija	
18418		10



ODVIJAČ PHILIPS



Br.	Specifikacija	
18201	0 x 75 mm	10
18202	1 x 75 mm	10
18203	2 x 100 mm	10
18204	3 x 150 mm	10



ODVIJAČ KOMPLET

⊖ S 3x60 · 4x75 · 6x100 · 6x125 mm

⊕ PH 0x60 · 1x75 · 2x100 mm



Br.	Specifikacija	
18400		10



ODVIJAČ POZIDRIVE



Br.	Specifikacija	
18301	0 x 75 mm	10
18302	1 x 75 mm	10
18303	2 x 100 mm	10
18304	3 x 150 mm	10



ODVIJAČ KOMPLET

⊖ S 3x60 · 6x100 · 6x125 mm

⊕ PH 1x75 · 2x100 mm



Br.	Specifikacija	
18401		1



FESTA

ODVIJAČ T SA NASTAVKOM ZA BITOVE - KRCKALICA

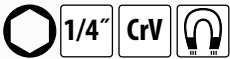

Br. 18608 Specifikacija

6



FESTA

ODVIJAČ SA NASTAVKOM ZA BITOVE - KRCKALICA

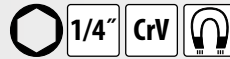

Br. 18433 Specifikacija

18433

6



FESTA

ODVIJAČ SA NASTAVKOM ZA BITOVE

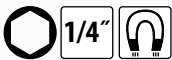

Br. 18110 Specifikacija

18110

12



FESTA

ODVIJAČ FLEKOMIBILNI



Br. 18451 Specifikacija

18451

12



FESTA

ODVIJAČ KOMPLET 7 UMETKA

⊖ S 5 · 6 mm

⊕ PH 1 · 2 · 3

★ T 15 · 20

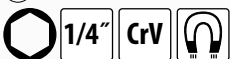

Br. 18425 Specifikacija

18425

10

FESTA

ODVIJAČ FLEKOMIBILNI



Br. 18450 Specifikacija

18450

7 mm

6



**FESTA**

KOMPLET ODVIJAČA I BITOVA

1/4" → 1/4"

S 3 · 4 · 5 · 6 · 7 · 5 L

PH 1 · 2 · 3 · 1 L · 2 L

PZ 1 · 2 · 3 · 1 L · 2 L

H 2 · 2.5 · 3 · 4 · 5 · 6

T 10 · 15 · 20 · 25 · 27 · 30

SQ 0 · 1 · 2 · 3

1/4" 5 · 6 · 7 · 8 · 9 · 10 · 11 · 12 · 13 mm

1/4" 45x



Br. Specifikacija

18419

6

**FESTA**

PRECIZNI ODVIJAČI

S 1,5x50 · 2x50 · 2,5x50 mm

PH 000x50 · 00x50 · 0x50 mm

6x



Br. Specifikacija

18416

6

**FESTA**

PRECIZNI ODVIJAČI ELEKTRO

S 2,4 · 3,0 mm

PH 0 · 1

T 6 · 8

6x



Br. Specifikacija

18415

10

**FESTA**

ODVIJAČ T + 20 NASTAVAKA

S 3 · 4 · 5 · 6 · 8 mm

PH 0 · 1 · 2 · 3

adapter + 5 · 6 · 7 · 8 · 9 · 10 · 11 · 12 · 13 mm

1/4" 20x



Br. Specifikacija

18420

5

**FESTA**

PRECIZNI ODVIJAČI

T 4 · 5 · 6 · 7 · 8 · 9 · 10x50 mm

7x



Br. Specifikacija

18417

6

**FESTA**

KOMPLET FINIH BITOVA SA ADAPTEROM

S 1.5 · 2 · 2.5 · 3 · 3.5 mm

PH 000 · 00 · 0 · 1

PZ 0 · 1

T 5 · 6 · 7 · 8 · 9 · 10 · 15 · 20

H 0.9 · 1.3 · 2.0 · 2.5 · 3.0 · 4.0

50x



Br. Specifikacija

18431

6



ODVIJAČ ČASOVNIČARSKI

⊖ S 1,4 · 2,0 · 2,4 · 3,0 mm

⊕ PH 0 · 1



6x HOBBY



Br. Specifikacija
18408

10

ODVIJAČ ČASOVNIČARSKI

⊖ S 1,0 · 1,2 · 1,4 · 1,8 · 2,4 · 3,0 mm

⊕ PH 00 · 0 · 1



11x HOBBY



Br. Specifikacija
18409

48



ADAPTER 90°



Br. Specifikacija
18910



25



KRCKALICA ZA BIT

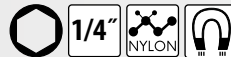

Br. Specifikacija
18435 93 mm



1

Stahlberg



Stahlberg

Nastavci od najkvalitetnijih materijala CrV S2

Proizvoač STAHLBERG

marka svetskog proizvođača nastavaka za odvijače sa dugogodišnjim iskustvom i klijentima po cijelom svijetu. U proizvodnji se koriste najnovije i najkvalitetnije tehnologije.

Tehnologija proizvodnje

Krstasti i pljosnati nastavci su proizvedeni specijalnom tehnologijom preciznog kovanja koja omogućava postizanje visoke točnosti oblika i ujedno povećane otpornosti i do 20%. Nakon kovanja su nastavci kaljeni tako da dobiju optimalnu tvrdoću i izdržljivost. Kako bi se osiguralo ne klizanje dodatno su pjeskareni.



TiN sloj

Dvostruko nanesen sloj na području kontakta sa vijkom maksimalno povećava tvrdoću i habanje, a peskarenjem se postiglo da ne proklizavaju prilikom korištenja

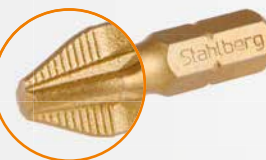

Dijamantna zrna

Prilikom korištenja se doslovice 'zagrizu' za glavu vijka a drže se i prilikom maksimalnog okreta.



Nerđajući nastavak

Radna površina vrha nastavka izrađena sa velikom zaštitnom protekcijom od klizanja tj. ispadanja iz ležišta gde su postavljeni



NEW

Stahlberg
BIT PH



S2

2x



Br.	Specifikacija	
18632A	PH2 x 25 mm	1
18633A	PH3 x 25 mm	1

NEW

Stahlberg
BIT PZ



S2

2x



Br.	Specifikacija	
18636A	PZ1 x 25 mm	1
18637A	PZ2 x 25 mm	1
18638A	PZ3 x 25 mm	1

NEW

Stahlberg
BIT T



S2

2x



Br.	Specifikacija	
18827A	T20 x 25 mm	1
18828A	T25 x 25 mm	1
18830A	T30 x 25 mm	1
18831A	T40 x 25 mm	1

Stahlberg
BIT PH DIJAMANT



DIN 3128



MOQ 5



Br.	Specifikacija	
18770	PH1 x 25 mm	5
18771	PH2 x 25 mm	5
18772	PH3 x 25 mm	5

Stahlberg
BIT PZ DIJAMANT



DIN 3128



MOQ 5



Br.	Specifikacija	
18775	PZ1 x 25 mm	5
18776	PZ2 x 25 mm	5
18777	PZ3 x 25 mm	5

Stahlberg
BIT S



S2



MOQ 5



Br.	Specifikacija	
18620	S 3 x 25 mm	5
18621	S 4 x 25 mm	5
18623	S 5 x 25 mm	5
18625	S 6 x 25 mm	5
18627	S 7 x 25 mm	5
18628	S 8 x 25 mm	5

Stahlberg
BIT PH



S2



MOQ 5



Br.	Specifikacija	
18630	PH0 x 25 mm	5
18631	PH1 x 25 mm	5
18632	PH2 x 25 mm	5
18633	PH3 x 25 mm	5
18634	PH4 x 25 mm	5

Stahlberg
BIT PZ



S2



MOQ 5



Br.	Specifikacija	
18635	PZ0 x 25 mm	5
18636	PZ1 x 25 mm	5
18637	PZ2 x 25 mm	5
18638	PZ3 x 25 mm	5
18639	PZ4 x 25 mm	5

Stahlberg
BIT PH



S2



MOQ 25



Br.	Specifikacija	
18685	PH2 x 25 mm	25

Stahlberg
BIT PZ



S2



MOQ 25



Br.	Specifikacija	
18680	PZ2 x 25 mm	25

Stahlberg
BIT PH



S2



MOQ 10



Br.	Specifikacija	
18640	PH1 x 70 mm	10
18641	PH2 x 70 mm	10

Stahlberg
BIT PZ



S2



MOQ 10



Br.	Specifikacija	
18645	PZ1 x 70 mm	10
18646	PZ2 x 70 mm	10

Stahlberg
BIT PH



S2 TiN



MOQ 5



Br.	Specifikacija	
18760	PH0 x 25 mm	5
18761	PH1 x 25 mm	5
18762	PH2 x 25 mm	5
18763	PH3 x 25 mm	5
18764	PH4 x 25 mm	5

Stahlberg
BIT PZ



S2 TiN



MOQ 5



Br.	Specifikacija	
18765	PZ0 x 25 mm	5
18766	PZ1 x 25 mm	5
18767	PZ2 x 25 mm	5
18768	PZ3 x 25 mm	5
18769	PZ4 x 25 mm	5

Stahlberg
BIT S



S2 TiN



MOQ 5



Br.	Specifikacija	
18750	S 3 x 25 mm	5
18751	S 4 x 25 mm	5
18753	S 5 x 25 mm	5
18755	S 6 x 25 mm	5

Stahlberg

BIT H



S2



MOQ 5



Br.	specifikacija	
18800	H 1,5 x 25 mm	5
18801	H 2,0 x 25 mm	5
18802	H 2,5 x 25 mm	5
18803	H 3,0 x 25 mm	5
18804	H 4,0 x 25 mm	5
18805	H 5,0 x 25 mm	5
18806	H 5,5 x 25 mm	5
18807	H 6,0 x 25 mm	5

Stahlberg

BIT TTA



S2



MOQ 5



Br.	specifikacija	
18835	TTa 5 x 25 mm	10
18836	TTa 6 x 25 mm	5
18837	TTa 7 x 25 mm	5
18838	TTa 8 x 25 mm	5
18839	TTa 9 x 25 mm	5
18840	TTa 10 x 25 mm	5
18841	TTa 15 x 25 mm	5
18842	TTa 20 x 25 mm	5
18843	TTa 25 x 25 mm	5
18844	TTa 27 x 25 mm	5
18845	TTa 30 x 25 mm	5
18846	TTa 40 x 25 mm	5
18847	TTa 45 x 25 mm	5

Stahlberg

BIT T



S2



MOQ 5



Br.	specifikacija	
18820	T5 x 25 mm	5
18821	T6 x 25 mm	5
18822	T7 x 25 mm	5
18823	T8 x 25 mm	5
18824	T9 x 25 mm	5
18825	T10 x 25 mm	5
18826	T15 x 25 mm	5
18827	T20 x 25 mm	5
18828	T25 x 25 mm	5
18829	T27 x 25 mm	5
18830	T30 x 25 mm	5
18831	T40 x 25 mm	5
18832	T45 x 25 mm	5

Stahlberg

BIT HTA



S2



MOQ 5



Br.	specifikacija	
18810	HTa 1,5 x 25 mm	5
18811	HTa 2,0 x 25 mm	5
18812	HTa 2,5 x 25 mm	5
18813	HTa 3,0 x 25 mm	5
18814	HTa 4,0 x 25 mm	5
18815	HTa 5,0 x 25 mm	5
18816	HTa 5,5 x 25 mm	5
18817	HTa 6,0 x 25 mm	5

Stahlberg

BIT T



S2



MOQ 3



Br.	specifikacija	
17980	T30 x 35 mm	3
17981	T40 x 35 mm	3

Br.	specifikacija	
17982	T45 x 35 mm	3
17983	T50 x 35 mm	3

Stahlberg

BIT SQ



S2



MOQ 5



Br.	specifikacija	
18850	SQ 0 x 25 mm	5
18851	SQ 1 x 25 mm	5
18852	SQ 2 x 25 mm	5
18853	SQ 3 x 25 mm	5

Stahlberg

BIT T



S2



MOQ 3



Br.	specifikacija	
17970	T20 x 75 mm	3
17971	T25 x 75 mm	3
17972	T30 x 75 mm	3
17973	T40 x 75 mm	3

Br.	specifikacija	
17974	T45 x 75 mm	3
17975	T50 x 75 mm	3
17976	T55 x 75 mm	3

Stahlberg

BIT SD



S2



MOQ 5



Br.	specifikacija	
18855	SD 6 x 25 mm	5
18856	SD 8 x 25 mm	5

Stahlberg

BIT TS



S2



MOQ 5



Br.	specifikacija	
18864	TS 4 x 25 mm	5
18865	TS 6 x 25 mm	5

Stahlberg

BIT 5/32', 3/16'



S2



MOQ 5



Br.	specifikacija	
18866	5/32 x 25 mm	5
18867	3/16 x 25 mm	5

Stahlberg

BIT TW



S2



MOQ 5



Br.	specifikacija	
18860	TW 1 x 25 mm	5
18861	TW 2 x 25 mm	5
18862	TW 3 x 25 mm	5
18863	TW 4 x 25 mm	5



Stahlberg
BIT XZN



Br.	specifikacija	MOQ
18870	M4 x 25 mm	5
18871	M5 x 25 mm	5
18872	M6 x 25 mm	5
18873	M8 x 25 mm	5
18874	M10 x 25 mm	5



Stahlberg
BITOVI ZA GIPSANE PLOČE



Br.	specifikacija	MOQ
18795	PH 2 x 25 mm	24



Stahlberg
BITOVI ZA GIPSANE PLOČE



Br.	specifikacija	MOQ
18796	PH 2 x 55 mm	24



Stahlberg
BIT ADAPTER

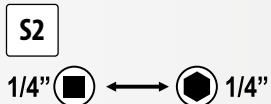

Br.	specifikacija	MOQ
18868	25 mm	5



Stahlberg
BIT ADAPTER



Br.	specifikacija	MOQ
18869	50 mm	5



Stahlberg
ADAPTER KRCKALICA 1/4' - BIT

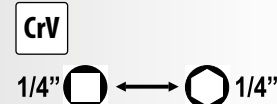

Br.	specifikacija	MOQ
18619		5



Stahlberg
NASTAVAK ZA BITOVE



Br.	specifikacija	MOQ
18600	1/4' x 60 mm	5



Stahlberg
NASTAVAK ZA BITOVE



Br.	specifikacija	MOQ
18797	1/4' x 60 mm	1



Stahlberg
NASTAVAK ZA BITOVE

· Quick grip | Цанга за бърза смяна



Br.	specifikacija	MOQ
18601	1/4' x 60 mm	5



Stahlberg
NASTAVAK ZA BITOVE

· Quick grip | Цанга за бърза смяна



Br.	specifikacija	MOQ
18798	1/4' x 60 mm	1



Stahlberg

NASTAVAK ZA BITOVE

• Sa graničnikom | Със стопер

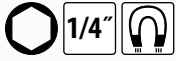

Br.	specifikacija	
18602	1/4" x 60 mm	5



Stahlberg

NASTAVAK ZA BITOVE

• Sa graničnikom | Със стопер



Br.	specifikacija	
18799	1/4" x 60 mm	1

NEW



Stahlberg

NASTAVAK ZA BITOVE



Br.	specifikacija	
18605	150 mm	25

NEW



FESTA

ADAPTER SDS + ZA BITOVE 1/4"



Br.	specifikacija	
20743	75 mm	1



NASTAVAK ZA BITOVE



Br.	specifikacija	
18607	80 mm	25



Stahlberg

ADAPTER 1/4'

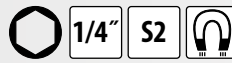

Br.	specifikacija		Br.	specifikacija	
18610	6 mm	5	18613	10 mm	5
18611	7 mm	5	18614	12 mm	5
18612	8 mm	5	18615	13 mm	5

KOMPLET ADAPTERA

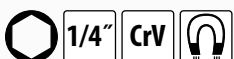

8x

Br.	specifikacija	
18618	6, 7, 8, 9, 10, 11, 12, 13 mm	



Br.	specifikacija	
		12



KOMPLET NASTAVAKA I ADAPTERA

10x	⊕	18630	PH0
10x	⊕	18631	PH1
10x	⊕	18632	PH2
10x	⊕	18633	PH3
10x	⊗	18635	PZ0
10x	⊗	18636	PZ1
10x	⊗	18637	PZ2
10x	⊗	18638	PZ3
10x	⊕	18761	PH1 TiN
10x	⊕	18762	PH2 TiN
10x	⊕	18763	PH3 TiN
10x	⊗	18766	PZ1 TiN
10x	⊗	18767	PZ2 TiN
10x	⊗	18768	PZ3 TiN
10x	⊕	18770	PH1 DIAMANT
10x	⊕	18771	PH2 DIAMANT
10x	⊗	18775	PZ1 DIAMANT
10x	⊗	18776	PZ2 DIAMANT
10x	●	18814	4,0HTa
10x	●	18815	5,0HTa
10x	⊗	18842	20TTa
10x	⊗	18845	30TTa
10x	⊕	18795	PH2 Za gipsane ploče
5x		18612	Adapter 1/4" 8mm
5x		18613	Adapter 1/4" 10mm
5x		18600	Magnetni nastavak 1/4" 60mm
5x		18601	Magnetni nastavak quick grip 1/4" 60mm
5x		18602	Magnetni nastavak, sa graničnikom 1/4" 65mm



Br. specifikacija

18993



1

KOMPLET NASTAVAKA

10x	⊕	18631	PH1
10x	⊕	18632	PH2
10x	⊕	18633	PH3
10x	⊗	18636	PZ1
10x	⊗	18637	PZ2
10x	⊗	18638	PZ3
10x	⊕	18761	PH1 TiN
10x	⊕	18762	PH2 TiN
10x	⊕	18763	PH3 TiN
10x	⊗	18766	PZ1 TiN
10x	⊗	18767	PZ2 TiN
10x	⊗	18768	PZ3 TiN
10x	●	18804	H 4
10x	●	18805	H 5
10x	⊗	18825	T 10
10x	⊗	18826	T 15
10x	⊗	18827	T 20
10x	⊗	18828	T 25
10x	⊗	18830	T 30
10x	⊗	18831	T 40

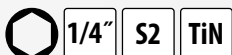

Br. specifikacija

18994



1

FESTA

KOMPLET BITOVA

- ⊕ S 3 · 4 · 5 · 6
 - PH 1 · 2 · 3
 - ⊖ PZ 1 · 2 · 3
 - H 3 · 4 · 5 · 6
 - ⊕ T 10 · 15 · 20 · 25 · 27 · 30 · 40
 - ⊕ TTa 10 · 15 · 20 · 25 · 27 · 30 · 40
- Magnetni nastavak quick grip

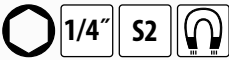

32x

Br. specifikacija

18905



10



FESTA

KOMPLET BITOVA

- ⊕ S 4 · 5 · 6
 - ⊖ PH 1 · 2 · 3
 - ⊕ PZ 1 · 2 · 3
 - H 3 · 4 · 5 · 6
 - ⊕ T 10 · 15 · 20 · 25 · 27 · 30 · 40
 - TTa 10 · 15 · 20 · 25 · 27 · 30 · 40
- Magnetni nastavak quick grip

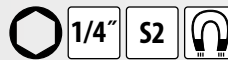

57x

Br. specifikacija

18906



6



FESTA

KOMPLET BITOVA

- HTa 2 · 2.5 · 3 · 4 · 5 · 6
5/32" · 9/64" · 1/8"
7/64" · 3/32" · 5/64"
 - SD 4 · 6 · 8 · 10
 - ⊕ TS 6 · 8 · 10
 - ⊕ TW 1 · 2 · 3 · 4
 - ⊕ TTa 8 · 10 · 15 · 20 · 25 · 27 · 30 · 35 · 40
- Magnetni nastavak

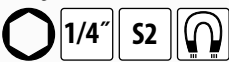

33x

Br. specifikacija

18900



10

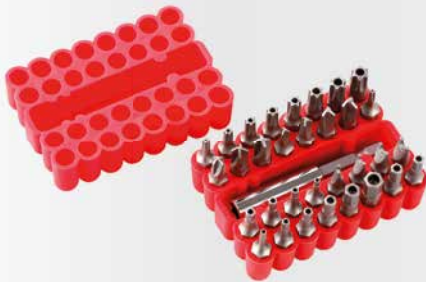

FESTA

KOMPLET BITOVA

- S 3 · 4 · 4.5 · 5 · 5.5 · 6 · 6.5 · 7 · 8
 - ⊕ PH 0 · 1 · 2 · 3
 - ⊕ PZ 0 · 1 · 2 · 3
 - ⊖ SQ 0 · 1 · 2 · 3
 - ⊕ T 8 · 10 · 15 · 20 · 25 · 27 · 30 · 40 · 45
 - ⊕ TTa 8 · 10 · 15 · 20 · 25 · 27 · 30 · 35 · 40
 - H 1.5 · 2 · 2.5 · 3 · 4 · 5 · 5.5 · 6 · 8 mm
1/16" · 5/64" · 3/32" · 7/64" · 1/8" · 9/64"
5/32" · 3/16" · 7/32" · 1/4"
 - HTa 2 · 2.5 · 3 · 4 · 5 · 6 mm
5/64" · 3/32" · 7/64" · 1/8" · 9/64" · 5/32"
 - SD 4 · 6 · 8 · 10
 - ⊕ TS 6 · 8 · 10
 - ⊕ TW 1 · 2 · 3 · 4
 - ⊕ 2-wing 1 · 2 · 3
 - XZN 5 · 6 · 8
- Magnetni nastavak
Nastavak „Y“
1/4" DR nastavak za odvijač
1/4" adapter: 25mm, 50mm

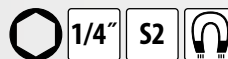

100x

Br. specifikacija

18909



24

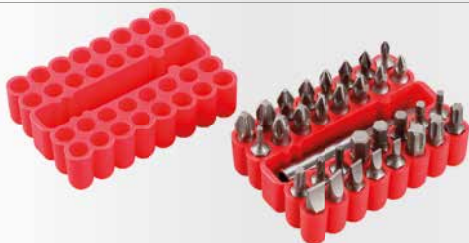

FESTA

KOMPLET BITOVA

- ⊖ S 3 · 4 · 5 · 6 · 7
 - ⊕ PH 0 · 1 · 2 · 3
 - PZ 1 · 2 · 3
 - ⊕ H 2 · 2.5 · 3 · 4 · 5 · 6
 - ⊕ T 10 · 15 · 20 · 25 · 30 · 40
- Magnetni nastavak

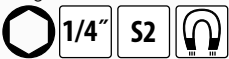

33x

Br. specifikacija

18901



10

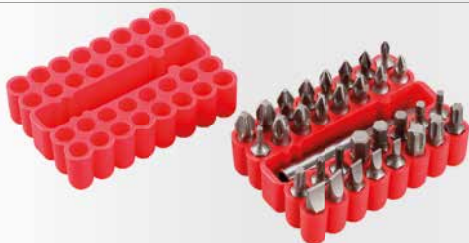



KOMPLET BITOVA

- ⊖ S 4 · 5 · 6 · 7
- ⊕ PH 1 · 2 · 3
- ✱ PZ 1 · 2 · 3
- H 4 · 5 · 6
- ★ T 10 · 15 · 20 · 25
- SQ 1 · 2 · 3

S2

20x



10

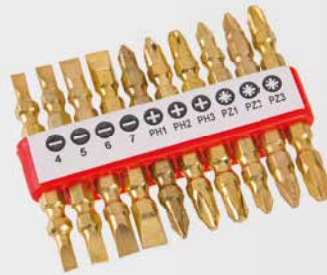

KOMPLET BITOVA

- ⊖ S 4 · 5 · 6 · 7
- ⊕ PH 1 · 2 · 3
- ✱ PZ 1 · 2 · 3

CrV TiN

10x



10



KOMPLET BITOVA

- ⊖ S 3 · 5 · 7
 - ⊕ PH 1 · 2 · 3
- Magnetni nastavak

HOBBY

7x



20

Br. specifikacija

Br. specifikacija

Br. specifikacija



KOMPLET BITOVA

- ⊕ S 3 · 4 · 4,5 · 5 · 5,5 · 6 · 7
- ⊖ PH 1 · 2 · 3
- PZ 1 · 2 · 3
- H 2 · 3 · 4 · 5
- ★ T 20 · 30
- 1/4" 4 · 4,5 · 5 · 5,5 · 6 · 7 · 8 · 9 · 10
- 5/32" · 3/16" · 7/32" · 1/4" · 9/32" · 5/16" · 11/32" · 3/8" · 7/16"

Magnetni odvijač
Magnetni nastavak
2 kom adapter

1/4" CrV

41x



10



KOMPLET BITOVA

- ⊕ S 3 · 3,5 · 4 · 5,5
- ✱ PH 0 · 1 · 2 · 3
- ⊖ PZ 0 · 1 · 2 · 3
- H 3 · 4
- ★ T 10 · 15 · 20 · 25 · 27 · 30
- 1/4" 4 · 4,5 · 5 · 5,5 · 6 · 7 · 8 · 9 · 10 · 11 · 13

Nastavak za odvijač 1/4"
Magnetni nastavak

CrV 1/4"

40x



10

Br. specifikacija

Br. specifikacija

KOMPLET ALATA

- ⊖ S 5 · 6 mm
- ⊕ PH 1 · 2
- H 3 · 4 · 5 · 6
- ★ T 15 · 20 · 25 · 30
- 1/4" 4 · 5 · 6 · 7 · 8 · 9 · 10 · 12 · 13 mm

75 mm 1/4" 1/4" 1/4"

1/4" CrV

23x















10

Br. specifikacija

Br. specifikacija

KOMPLET ALATA

-  120mm
-  125mm
-  115mm
-  150mm max. 19mm
-  9mm
-  1/4" 160mm
-  5 · 6 · 7 · 8 · 9 · 10 · 11 mm
-  1/4"
-  1/4"

-  S 4 · 6 mm
-  PH 1 · 2 · 3
-  PZ 1 · 2
-  H 4 · 5 · 6

35x































Br. 17260
specifikacija



10

FESTA

KOMPLET ALATA

-  1/2", 1/4"
-  1/4" · 4-5-6-7-8-9mm
-  1/2" · 10-12-13-14-17-19mm
-  1/4" · 4-4.5-5-5.5-6-7-8-9-10-11-12-13-14mm
-  1/2" · 12-13-14-15-16-17-18-19-20-21-22-24mm
-  1/2", 1/4"
-  1/4" → 1/4"
-  1/4" · 150mm
-  1/2" · 254mm
-  1/2", 1/4"
-  1/2" · 16-21mm
-  1/4" · 150mm
-  1/2" · E10-E12-E14-E16-E18-E20-E22-E24
-  1/4" · S 3 · 4 · 5 · 6
-  1/4" · PH 0 · 1 · 2
-  1/4" · PZ 0 · 1 · 2
-  1/4" · S 4 · 5.5 · 6.5
-  1/4" · PH 1 · 2 · 3
-  1/4" · PZ 2 · 3
-  1/4" · H 3 · 4 · 5 · 6
-  1/4" · T 8 · 10 · 15 · 20 · 25
-  1/4" · TTα 10 · 15 · 20 · 25 · 40
-  2 · 2.5 · 3 · 4 · 5 · 6 · 7 · 8 · 10mm
-  8-9-10-11-12-13-14-15-16-17-18-19mm
-  S 4x100 · 6,5x150
-  PH 2x100 · 3x150
-  180mm
-  160mm
-  160mm
-  250mm
-  300g

CrV S2 1/4" 1/2" 72T

122x

Br. 17238
122 kom. specifikacija



1

KOMPLET ALATA

- 160 mm
- 160 mm
- 300 g
- 1/4" 45T
- 4 · 5 · 6 · 7 · 8 · 9 · 10 · 11 · 12 · 13 mm
- 1/4" 75 mm
- 1,5 · 2 · 2,5 · 3 · 4 · 5 · 6 · 8 · 10 mm
- S 3 · 4 · 5 · 6 mm
- PH 0 · 1 · 2 · 3
- PZ 0 · 1 · 2 · 3
- T 10 · 15 · 20 · 25
- H 3 · 4 · 5 · 6
- S 5x100 mm
- PH 1x100 · 2x100 mm
- S 2,5x50 mm
- PH 00x50 · 0x50 mm
- AC 100-250 V
- 200 mm max. 22 mm
- 10x11 · 12x13 · 14x15 · 16x17 mm
- 18 mm
- 2 m 13 mm



60x

Br. specifikacija

17259



5

KOMPLET ALATA

- 1/4" 5 · 6 · 7 · 8 · 9 · 10 · 11 · 12 mm
- 1/4"
- 1/4"
- AC 230 V
- PH 0, SL 3
- 9x 1,5-10 mm
- 160 mm
- S 3 · 4 · 5 · 6 mm
- PH 0 · 1 · 2 · 3
- H 4 · 5
- PH 2x100, S 6x100
- 18 mm
- 1 m
- 300 g



32x

Br. specifikacija

17247



10

FESTA

ODVIJAČ INBUS KOMPLET

- H 1,5 mm
- H 2 mm
- H 2,5 mm
- H 3 mm
- H 4 mm
- H 5 mm
- H 6 mm
- H 8 mm
- H 10 mm



9x



Br. specifikacija 18496 5

FESTA

ODVIJAČ INBUS KOMPLET SA KUGLICOM

- H 1,5 mm
- H 2 mm
- H 2,5 mm
- H 3 mm
- H 4 mm
- H 5 mm
- H 6 mm
- H 8 mm
- H 10 mm



9x



Br. specifikacija 18500 5

FESTA

ODVIJAČ INBUS PRODUŽENI KOMPLET

- H 1,5 mm
- H 2 mm
- H 2,5 mm
- H 3 mm
- H 4 mm
- H 5 mm
- H 6 mm
- H 8 mm
- H 10 mm



9x



Br. specifikacija 18490 5

FESTA

ODVIJAČ INBUS KOMPLET SA KUGLICOM

- H 1,5 mm
- H 2 mm
- H 2,5 mm
- H 3 mm
- H 4 mm
- H 5 mm
- H 6 mm
- H 8 mm
- H 10 mm



9x



Br. specifikacija 18498 5

FESTA

ODVIJAČ INBUS KOMPLET SA KUGLICOM

- 1/16"
- 5/64"
- 3/32"
- 1/8"
- 5/32"
- 3/16"
- 1/4"
- 5/16"
- 3/8"



9x



Br. specifikacija 18493 6

FESTA

ODVIJAČ TORX KOMPLET

- T 10 mm
- T 15 mm
- T 20 mm
- T 25 mm
- T 27 mm
- T 30 mm
- T 40 mm
- T 45 mm
- T 50 mm



9x



Br. specifikacija 18497 5

FESTA

ODVIJAČ INBUS PRODUŽENI KOMPLET SA KUGLICOM

- H 1,5 mm
- H 2 mm
- H 2,5 mm
- H 3 mm
- H 4 mm
- H 5 mm
- H 6 mm
- H 8 mm
- H 10 mm



9x



Br. specifikacija 18492 10

FESTA

ODVIJAČ TORX PRODUŽENI KOMPLET

- T 10 mm
- T 15 mm
- T 20 mm
- T 25 mm
- T 27 mm
- T 30 mm
- T 40 mm
- T 45 mm
- T 50 mm



9x

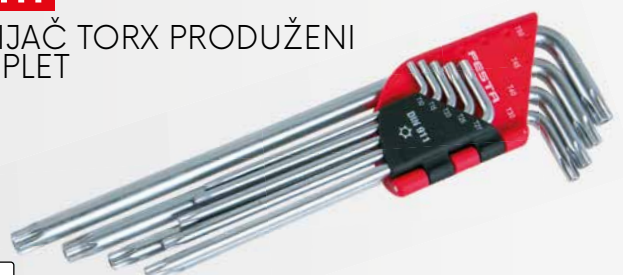

Br. specifikacija 18491 5

**FESTA**

ODVIJAČ INBUS



Br.	specifikacija		
18548	8 mm	36 x 100 mm	1
18559	19 mm	70 x 180 mm	1
18562	22 mm	80 x 200 mm	1
18567	27 mm	100 x 250 mm	1
18572	32 mm	125 x 315 mm	1

**FESTA**

ODVIJAČ INBUS PRODUŽENI SA KUGLICOM



Br.	specifikacija		
18575	1,5 mm	15 x 75 mm	1
18576	2 mm	17 x 81 mm	1
18577	2,5 mm	18 x 87 mm	1
18578	3 mm	20 x 96 mm	1
18579	4 mm	24 x 107 mm	1
18580	5 mm	30 x 120 mm	1
18581	6 mm	33 x 136 mm	1
18582	7 mm	34 x 144 mm	1
18583	8 mm	36 x 153 mm	1
18584	9 mm	38 x 155 mm	1
18585	10 mm	40 x 171 mm	1
18586	11 mm	40 x 230 mm	1
18587	12 mm	42 x 250 mm	1
18588	13 mm	45 x 260 mm	1
18589	14 mm	56 x 280 mm	1
18593	17 mm	61 x 290 mm	1

**FESTA**

ODVIJAČ INBUS PRODUŽENI



Br.	specifikacija		
18510	1,5 mm	15 x 75 mm	1
18511	2 mm	17 x 81 mm	1
18512	2,5 mm	18 x 87 mm	1
18513	3 mm	20 x 96 mm	1
18514	4 mm	24 x 107 mm	1
18515	5 mm	30 x 120 mm	1
18516	6 mm	33 x 136 mm	1
18518	8 mm	36 x 153 mm	1
18519	9 mm	38 x 155 mm	1
18520	10 mm	40 x 171 mm	1
18521	11 mm	40 x 230 mm	1
18522	12 mm	42 x 250 mm	1
18523	13 mm	45 x 260 mm	1
18524	14 mm	56 x 280 mm	1
18527	17 mm	61 x 290 mm	1

**FESTA**

ODVIJAČ TORX



Br.	specifikacija	
18466	T7	1
18468	T9	1
18476	T45	1
18477	T50	1

**FESTA**

ODVIJAČ INBUS KOMPLET



Br.	specifikacija	
18508	1,5 · 2 · 2,5 · 3 · 4 · 5 · 6 mm	1



FESTA

KOMPLET T KLJUČEVA INBUS

- 2 mm
- 2,5 mm
- 3 mm
- 4 mm
- 5 mm
- 6 mm
- 7 mm
- 8 mm
- 10 mm



9x



Br.	specifikacija
18494	

6



FESTA

KOMPLET T KLJUČEVA TORX

- T 10
- T 15
- T 20
- T 25
- T 27
- T 30
- T 40
- T 45
- T 50



9x



Br.	specifikacija
18495	

6



ODVIJAČ INBUS KOMPLET



8x



Br.	specifikacija
18499	2 · 2,5 · 3 · 4 · 5 · 6 · 8 · 10 mm

1



FESTA

T KLJUČ TORX



Br.	specifikacija	
17350	T 7	10
17351	T 8	10
17352	T 9	10
17353	T 10	10

Br.	specifikacija	
17357	T 27	10
17359	T 40	10
17360	T 45	10
17361	T 50	10

FESTA®



ČEKIĆI



FESTA®

ČEKIĆ

· Drška jasen

DIN
1041

Br.	specifikacija	
19081	100 g	1
19082	200 g	1
19083	300 g	1
19084	400 g	1
19085	500 g	1
19086	600 g	1
19088	800 g	1
19090	1000 g	1
19092	1500 g	1
19095	2000 g	1



FESTA®

ČEKIĆ

· Drška jasen

DIN
1041

Br.	specifikacija	
19096	3000 g	1
19097	4000 g	1
19098	5000 g	1
19106	6000 g	1
19108	8000 g	1
19109	10000 g	1

NEW



FESTA®

MACOLA

· Drška jasen

DIN
6475

Br.	specifikacija	
19041	1000 g	1
19042	1250 g	1
19043	1500 g	1
19044	2000 g	1



FESTA®

MACOLA

· Drška jasen

DIN
6475

Br.	specifikacija	
19045	NEW 3000 g	1
19046	NEW 4000 g	1
19074	5000 g	1
19075	6000 g	1
19076	8000 g	1
19077	10000 g	1

**FESTA**

ČEKIĆ FIBERGLASS

· Fiberglass

Br.	specifikacija		Br.	specifikacija	
19021	100 g	12	19026	600 g	6
19022	200 g	12	19028	800 g	6
19023	300 g	12	19030	1000 g	6
19024	400 g	12	19031	1500 g	6
19025	500 g	12	19032	2000 g	1

**FESTA**

MACOLA FIBERGLASS

· Fiberglass

DIN 6475

Br.	specifikacija	
19066	1000 g	4
19067	1250 g	4
19068	1500 g	4
19069	2000 g	2



ČEKIĆ

· Kružni klin

DIN 1041

Br.	specifikacija	
19001	100 g	12
19002	200 g	12
19003	300 g	6
19004	400 g	6
19005	500 g	6
19006	600 g	6
19008	800 g	6
19010	1000 g	6
19015	1500 g	6
19020	2000 g	6

**FESTA**

ČEKIĆ FIBERGLASS

· Fiberglass

Br.	specifikacija	
19034	3000 g	4
19036	4000 g	4

**FESTA**

ČEKIĆ FIBERGLASS

· Fiberglass

DIN 6475

Br.	specifikacija	
19070	3000 g	4
19071	4000 g	4
19058	5000 g	4
19059	6000 g	2



MACOLA

· Kružni klin

DIN 6475

Br.	specifikacija	
19053	1000 g	6
19050	1250 g	6
19054	1500 g	6
19055	2000 g	6



MACOLA

· Kružni klin

DIN 6475

Br.	specifikacija	
19056	3000 g	6
19057	4000 g	6

**FESTA**

ČEKIČ OBUĆARSKI FIBERGLASS

Fiberglass

Br.	specifikacija	
19064	450 g	6

**FESTA**

ČEKIČ TESARSKI FIBERGLASS

Fiberglass



Br.	specifikacija	
19061	600 g	6

**FESTA**

ČEKIČ ZIDARSKI FIBERGLASS

Fiberglass

Br.	specifikacija	
19151	600 g	6

**FESTA**

ČEKIČ OBUĆARSKI MONOLIT

Br.	specifikacija	
19063	450 g	6

**FESTA**

ČEKIČ TESARSKI MONOLIT



Br.	specifikacija	
19062	600 g	6

**FESTA**

ČEKIČ MONOLIT

Br.	specifikacija	
19150	600 g	6



ČEKIČ TESARSKI



Br.	specifikacija	
19100	600 g	6



FESTA

ČEKIĆ OBUČARSKI

Br.	specifikacija	
19065	600 g	6



FESTA

ČEKIĆ TESARSKI



Br.	specifikacija	
19060	600 g	6



FESTA

MACOLA

Br.	specifikacija	
19051	1000 g	6
19052	1500 g	6



FESTA

ČEKIĆ - SEKIRA

Br.	specifikacija	
19303	600 g	6



FESTA

ČEKIĆ ZIDARSKI

• Drška jasen

Br.	specifikacija	
19149	44 mm	1



FESTA

ČEKIĆ ZIDARSKI

• Drška jasen

Br.	specifikacija	
19124	24 mm	1
19136	36 mm	1
19148	48 mm	1



VARILAČKI ČEKIĆ



Br.	specifikacija	
19115	300 g	1



FESTA

DRŽALJA ZA ČEKIĆE – JASEN

Br.	specifikacija	
61240	drška	1



DRŽALJA ZA ČEKIČE – JASEN



Br.	specifikacija	za čekiče	
61320	26 cm	19081	10
61321	28 cm	19082	10
61322	30 cm	19083	10
61323	31 cm	19084	10
61324	32 cm	19085	10



DRŽALJA ZA MACOLE – JASEN



Br.	specifikacija	za macole	
61330	80 cm	19074, 19075	10
61331	90 cm	19076, 19077	10



KRUŽNI KLIN

Br.	specifikacija	
19430	6 mm	10
19431	8 mm	10
19432	10 mm	10
19433	12 mm	10
19434	14 mm	10
19435	16 mm	10



KAJLICE



Br.	specifikacija	
19440	Uski	10
19441	Srednji	10
19442	Široki	10
19443	Široki S	10



FESTA

KAJLICE



Br.	specifikacija	
19398	20 x 25 x 5 mm	1
19399	30 x 40 x 5 mm	1

3x



FESTA

DRVENI ČEKIĆ

· Bukovo drvo



Br.	specifikacija			
19202	Ø 60 x 120 mm	350 g		1



FESTA

DRVENI ČEKIĆ

· Bukovo drvo



Br.	specifikacija			
19200	80 x 60 mm	520 g		1



FESTA

ČEKIĆ GUMENI

· Drška jasen



Br.	specifikacija			
19245	Ø 55 mm	400 g		1
19246	Ø 60 mm	800 g		1
19247	Ø 70 mm	1000 g		1
19248	Ø 95 mm	2000 g		1
19249	Ø 115 mm	3000 g		1



FESTA

ČEKIĆ GUMENI

· Fiberglass



Br.	specifikacija			
19270	Ø 55 mm			6
19271	Ø 65 mm			6
19272	Ø 90 mm			6



FESTA

ČEKIĆ GUMENI



Br.	specifikacija			
19255	Ø 55 mm			6
19265	Ø 65 mm			6
19290	Ø 90 mm			6



FESTA

ČEKIĆ BELA GUMA



Br.	specifikacija			
19293	NEW Ø 55 mm			6
19294	Ø 65 mm			6
19295	Ø 90 mm			6



ČEKIĆ GUMENI



Br.	specifikacija			
19254	Ø 65 mm			6



ČEKIČ GUMENI



Br.	specifikacija	
19251	Ø 55 mm 400 g	12
19252	Ø 65 mm 700 g	6
19253	Ø 90 mm 1300 g	4



FESTA

ČEKIČ MESING

· Fiberglass

Br.	specifikacija	
19211	Ø 30 mm 500 g	1



ČEKIČ SILIKONSKI

Br.	specifikacija	
19297	Ø 35 mm	12



FESTA

ČEKIČ NYLON

· Fiberglass

Br.	specifikacija	
19209	Ø 34 mm	6

FESTA

PALIČKA S VÝMĚNNÝMI KONCI

· PP - 97 Shore A



· TPE - 90 Shore A



· TPU - 92 Shore A



· TPU - 88 Shore A



TPU - 95 Shore A



TPE - 90 Shore A



TPU - 92 Shore A



TPE - 90 Shore A



Br.	specifikacija	
19208	Ø 40 mm	1

FESTA®

SEKIRE



FESTA®

SEKIRA

DIN 5131

DIN 7294

- Drška jasen
- Kružni klin

Br.	specifikacija		Br.	specifikacija	
19380	600 g	1	19384	1400 g	1
19381	800 g	1	19385	1600 g	1
19382	1000 g	1	19387	2000 g	1
19383	1250 g	1			



FESTA®

SEKIRA TESARSKA

- Drška jasen

Br.	specifikacija	
19340	700 g	22



FESTA®

ČEKIĆ SEKIRA

- Drška jasen
- Kružni klin

DIN 5129

Br.	specifikacija	
19389	3000 g	1
19388	4000 g	1



FESTA®

SEKIRA ZA CEPANJE

- Drška jasen
- Kružni klin

DIN 7294

Br.	specifikacija	
19391	2000 g	1



SEKIRA

Br.	specifikacija	
19306	600 g	24
19308	800 g	24
19310	1000 g	24
19312	1250 g	12
19314	1500 g	12



DRŽALJA ZA SEKIRE – JASEN



Br.	specifikacija	za čekiće	
61340	36 cm	19380	10
61341	40 cm	19381, 19340	10
61342	50 cm	19382	10
61343	70 cm	19383, 19384	10

Br.	specifikacija	za čekiće	
61344	80 cm	19385, 19391	10
61345	90 cm	19387	10
61346	90 cm	19388, 19389	10



FESTA

SEKIRA FIBERGLASS

· Fiberglass

Br.	specifikacija	
19326	600 g	6
19328	800 g	24
19330	1000 g	12



FESTA

SEKIRA CAMP FIBERGLASS

· Fiberglass

Br.	specifikacija	
19301	500 g	6



FESTA

SEKIRA ZA CEPANJE

· Fiberglass

Br.	specifikacija	
19392	1000 g	6



FESTA

SEKIRA ZA CEPANJE

· Fiberglass

Br.	specifikacija	
19390	2000 g	6



FESTA

ČEKIĆ SEKIRA

· Fiberglass

Br.	specifikacija	
19370	3000 g	4
19371	4000 g	4



Black Eagle

SEKIRA



Br.	specifikacija	
19356	1200 g	5
19357	1800 g	1



TRN ZA CEPANJE SDS+



Br.	Specifikacija	
19393	Ø 32 x 132 mm	10
19374	Ø 42 x 145 mm	10



KLIN ŠUMSKI

Br.	specifikacija	
19397	2000 g 55 x 210 x 45 mm	10
19465	2500 g 65 x 230 x 45 mm	10



KLIN ŠUMSKI

Br.	specifikacija	
19469	2500 g 165 x 87 mm	10



KLIN ŠUMSKI PLASTIČNI



Br.	specifikacija	
19462	175 x 65 x 20 mm	1
19463	230 x 70 x 30 mm	1
19464	240 x 75 x 40 mm	1



KLIN ŠUMSKI

Br.	specifikacija	
19394	1000 g 35 x 180 x 40 mm	6
19395	2000 g 40 x 255 x 55 mm	6
19396	2500 g 40 x 260 x 55 mm	8

FESTO
PAJSER

14 mm



Br.	specifikacija	
19424	400 mm	6
19425	600 mm	6
19426	800 mm	6
19427	1000 mm	6

PAJSER

Br.	specifikacija	
19416	600 mm Ø 16 mm	4
19422	800 mm Ø 16 mm	4
19421	1000 mm Ø 18 mm	4

PAJSER

Br.	specifikacija	
19423	380 x 35 x 6 mm	1

KUKA ZA EKOMERE

Br.	specifikacija	
19415	300 mm Ø 15 mm	6



FESTA

SEKAČ

CrV

Br.	specifikacija	širka hrotu	
19406	300 mm	25 mm	5
19407	400 mm	30 mm	5



FESTA

ŠPIC

CrV

Br.	specifikacija	
19408	250 mm	5
19409	350 mm	5



FESTA

SEKAČ

CrV

Br.	specifikacija	širka hrotu	
19460	300 mm	25 mm	5
19470	400 mm	30 mm	5



ŠPIC

Br.	specifikacija	
19400	250 mm	5
19403	350 mm	6



SEKAČ

Br.	specifikacija	širka hrotu	
19401	250 mm	19 mm	6
19404	350 mm	22 mm	6



SEKAČ

Br.	specifikacija	širka hrotu	
19402	250 mm	50 mm	2
19405	350 mm	50 mm	6



FESTA

SEKAČ

CrV

Br.	specifikacija	širka hrotu	
19410	200 mm	20 mm	10
19411	250 mm	25 mm	10
19412	300 mm	25 mm	10
19418	400 mm	25 mm	5
19419	500 mm	25 mm	5



SEKAČ

CrV

Br.	specifikacija	širka hrotu	
19436	200 mm	20 mm	15



DLETA



FESTA

DLETO

CrV



Br.	specifikacija	
19490	6 mm 275 mm	6
19491	8 mm 275 mm	6
19492	10 mm 275 mm	6
19493	12 mm 275 mm	6
19494	14 mm 275 mm	6
19495	16 mm 275 mm	6

Br.	specifikacija	
19496	18 mm 280 mm	6
19497	20 mm 280 mm	6
19498	22 mm 280 mm	6
19499	25 mm 280 mm	6
19501	32 mm 290 mm	6
19502	38 mm 290 mm	6

KOMPLET DLETA



4x

Br.	specifikacija	
19450		20

FESTA

KOMPLET DLETA SA BRUSOM

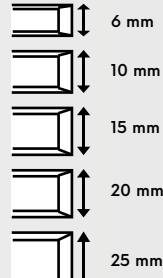

CrV 5x



Br.	specifikacija	
19451		10

FESTA

KOMPLET DLETA



CrV 4x



Br.	specifikacija	
19457		10



FESTA

DLETO

INOX

MOQ 12



Br.	specifikacija	
16231	20 80 mm	12

KOMPLET DLETA



4x

Br.	specifikacija	
19455		30

**FESTA****KOMPLET DLETA****CrV****8x**

Br.	specifikacija	
19458	365 125mm	1

**DLETA ZA REZBARENJE****CrV****12x**

Br.	specifikacija	
19459		5

**RUČNI PLANER**

Br.	specifikacija	
19510	220 x 65 x 130 mm, nůž 48 mm	1

**RUČNI PLANER**

Br.	specifikacija	
19515	200 x 55 x 130 mm, nůž 39 mm	1

**RUČNI PLANER**

Br.	specifikacija	
19520	225 x 27 x 155 mm, nůž 27 mm	1

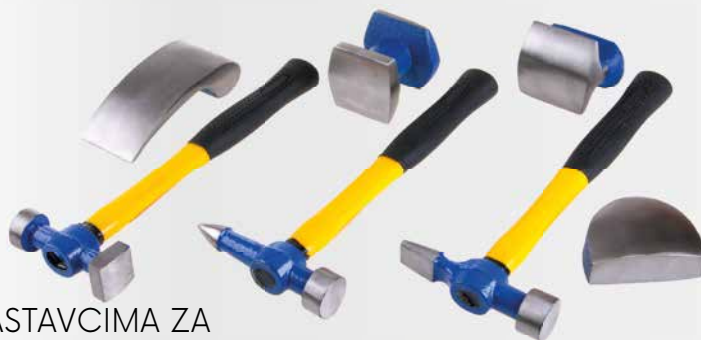
**SET ČEKIČA SA NASTAVCIMA ZA AUTO POPRAVKU****7x**

Br.	specifikacija	
19110		5



5

FESTA®



HEFTALICE

FESTA®

HEFTALICA 5 V 1

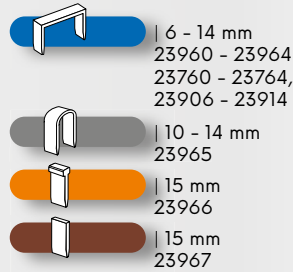
 Br. specifikacija
23927

6

FESTA®

HEFTALICA 4 V 1

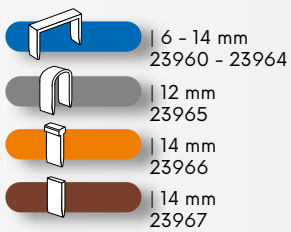
 Br. specifikacija
23924

12

FESTA®

HEFTALICA 3 V 1

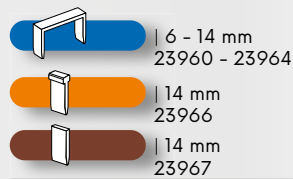
 Br. specifikacija
23923

12

FESTA®

HEFTALICA

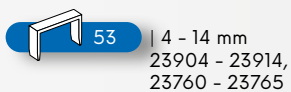
 Br. specifikacija
23925 4 - 14 mm with lock out

20

FESTA®

ODSTRANJIVAČ MUNICIJE



 Br. specifikacija
23945

25

HEFTALICA

 53 | 4 - 14 mm
23760 - 23765,
23904 - 23914



Br.	specifikacija	
23800		20

HEFTALICA

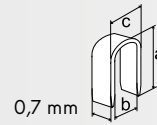

 $\alpha=9-11 \text{ mm}, b=5,5\text{mm}, c=6,4\text{mm}$



Br.	specifikacija	
23920		4

FESTA

HEFTALICA ČEKIĆ

 | 6 - 10 mm
23960 - 23962

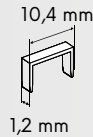

Br.	specifikacija	
23922		10

HEFTALICA ČEKIĆ

 | 6 - 10 mm
23960 - 23962



Br.	specifikacija	
23928		6

FESTA

MUNICIJA ZA HEFTALICU

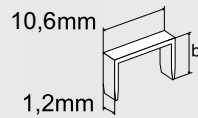

Br.	specifikacija	
23960	b=6 mm, 1000 kom.	50
23961	b=8 mm, 1000 kom.	50
23962	b=10 mm, 1000 kom.	50
23963	b=12 mm, 1000 kom.	50
23964	b=14 mm, 1000 kom.	50

MUNICIJA ZA HEFTALICU (TYP 53)

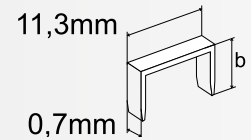

Br.	specifikacija	
23904	b=4 mm 1000 kom.	200
23906	b=6 mm 1000 kom.	200
23908	b=8 mm 1000 kom.	200
23910	b=10 mm 1000 kom.	200
23912	b=12 mm 1000 kom.	200
23914	b=14 mm 1000 kom.	200

FESTA

MUNICIJA ZA HEFTALICU

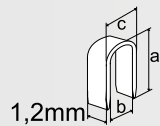

Br.	specifikacija	
23965	$\alpha=12 \text{ mm}, b=6,5 \text{ mm}, c=7,5 \text{ mm}, 1000 \text{ TW}$	50

FESTA

EKOMERI



Br.	specifikacija	
23966	14 mm 1000 TW	100

MUNICIJA ZA HEFTALICU (TYP 53)

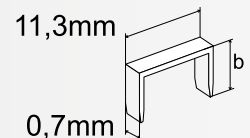

Br.	specifikacija	
23760	b=4 mm 2000 kom.	10
23761	b=6 mm 2000 kom.	10
23762	b=8 mm 2000 kom.	10
23763	b=10 mm 2000 kom.	10
23764	b=12 mm 2000 kom.	10

FESTA

EKOMERI



Br.	specifikacija	
23967	14 mm 1000 TW	100

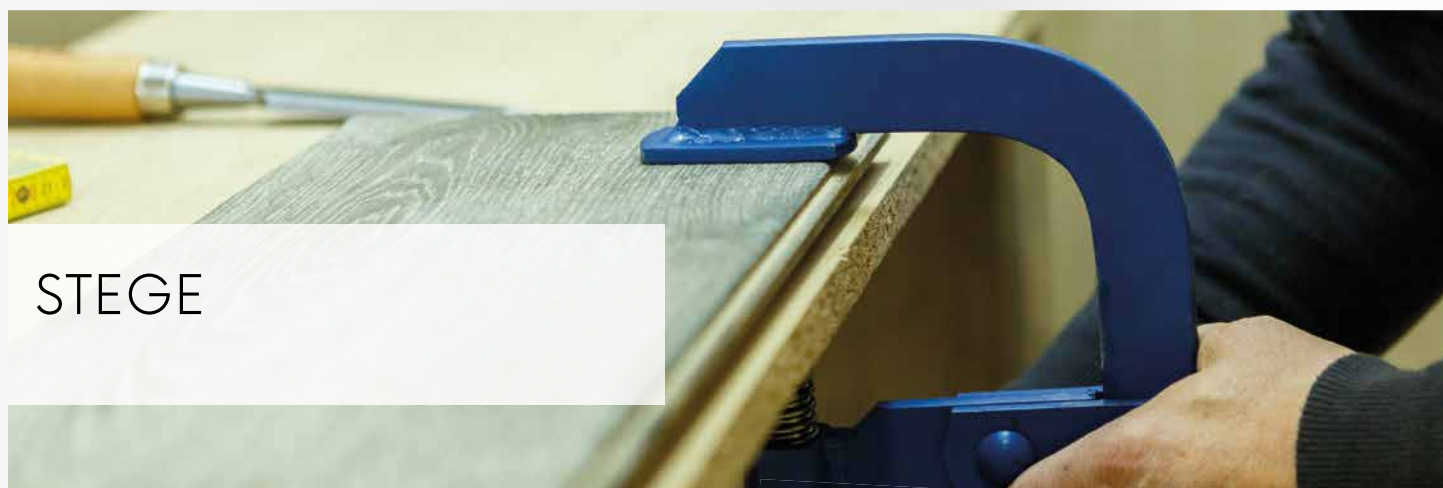

STEGE



FESTA

STEGA STOLARSKA AUTOMATSKA

· kovani



Br.	specifikacija	
23560	200 x 80 mm	1
23561	300 x 100 mm	1
23562	400 x 100 mm	1
23563	500 x 120 mm	1

Br.	specifikacija	
23564	600 x 120 mm	1
23565	800 x 120 mm	1
23566	1000 x 120 mm	1

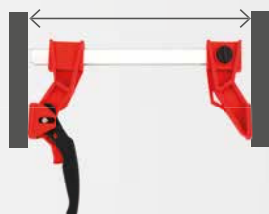

FESTA

QUICK GRIP CLAMP



Br.	specifikacija	
23570	100 x 80 mm	1
23571	160 x 80 mm	1
23572	200 x 80 mm	1
23573	250 x 80 mm	1
23574	300 x 80 mm	1



FESTA

STEGA STOLARSKA



Br.	specifikacija		Br.	specifikacija		Br.	specifikacija	
23670	150 x 105 mm	1	23676	500 x 175 mm	1	23682	1500 x 175 mm	1
23671	200 x 105 mm	1	23677	600 x 175 mm	1	23683	1750 x 175 mm	1
23672	250 x 105 mm	1	23678	700 x 175 mm	1	23684	2000 x 175 mm	1
23673	300 x 105 mm	1	23679	800 x 175 mm	1	23685	2200 x 175 mm	1
23674	350 x 105 mm	1	23680	1000 x 175 mm	1			
23675	400 x 175 mm	1	23681	1250 x 175 mm	1			





STEGA STOLARSKA

DIN 5117

Br.	specifikacija	
23506	300 x 120 mm	10
23507	500 x 120 mm	10
23508	800 x 120 mm	6

STEGA STOLARSKA

Br.	specifikacija	
23515	150 x 50 mm	50
23520	200 x 50 mm	50
23525	250 x 50 mm	50
23530	300 x 50 mm	50
23531	300 x 120 mm	20
23551	500 x 120 mm	10



FESTA

STEGA STOLARSKA AUTOMATSKA

Br.	specifikacija	
23625	200 mm	6
23626	300 mm	6
23628	450 mm	6
23630	600 mm	6
23632	760 mm	6

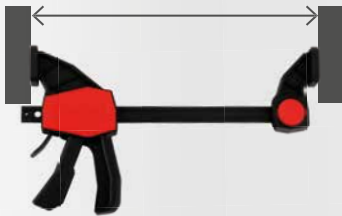

FESTA

STEGA STOLARSKA AUTOMATSKA

Br.	specifikacija	
23585	150 mm	6
23587	300 mm	6
23589	450 mm	6
23591	600 mm	6



STEGA

visina tona 80 mm

Br.	specifikacija	
23605	9' 230 mm	6

PLASTIČNA STEGA

Br.	specifikacija	
23600	4', visina tona 40 mm	20
23601	6', visina tona 50 mm	12
23602	9', visina tona 80 mm	20

STEGA KOMPLET

3x

Br.	specifikacija	
23620	25 mm, 50 mm, 75 mm	10

**FESTA****ŠKRIPAC**

· Ojačane čeljusti

Br.	specifikacija	
23410	100 mm	1
23411	125 mm	1
23412	150 mm	1

**ŠKRIPAC OKRETNI**

· Ojačane čeljusti

Br.	specifikacija	
23415	100 mm	1
23416	125 mm	1
23417	150 mm	1

**ŠKRIPAC MINI OKRETNI**

Br.	specifikacija	
23407	65 mm	10

**ŠKRIPAC POD BUŠILICU**

· Ojačane čeljusti

Br.	specifikacija	
23400	18 80 mm	10
23401	22 100 mm	10
23402	24 125 mm	5

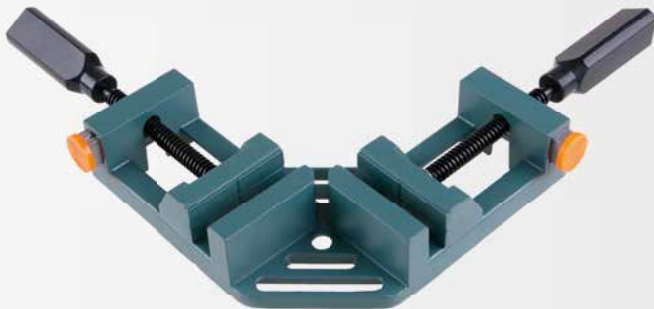
**ŠKRIPAC MINI OKRETNI 90°**

Br.	specifikacija	
23420	65 mm	20

ALU

· 0 - 65 mm

**ŠKRIPAC MINI OKRETNI 360°**

Br.	specifikacija	
23406	80 mm	24

ALU

NEW



RADNI STO NA SKLAPANJE

· max. 100 kg

Br.	Specifikacija
23655	100 x 50 x 84 cm



1



RADNI STO NA SKLAPANJE

· Idealan za podrum kabina

Br.	specifikacija
23660	



1



RADNI STO NA SKLAPANJE

Br.	specifikacija
23650	



1

NEW



FESTA

PODESEVI NASLON

· max.: 590 kg

Br. Specifikacije

23657



1

NEW



FESTA

PRENOSIVI ŠKRIPAC

· domet: 0 - 95 cm

· max.: 250 kg

Br. Specifikacije

37553



1

FESTA®

KLJEŠTA ZA POP NITNE



FESTA®

KLJEŠTA ZA POP NITNE

Cr-Mo

- Ø 2,4 mm
- Ø 3,2 mm
- Ø 4,0 mm
- Ø 4,8 mm



Br. 24007 specifikacija 200 mm

1



FESTA®

KLJEŠTA ZA POP NITNE

Cr-Mo

- Ø 2,4 mm
- Ø 3,2 mm
- Ø 4,0 mm
- Ø 4,8 mm



Br. 24010 specifikacija 250 mm

12



FESTA

KLJEŠTA ZA POP NITNE

Cr-Mo

- Ø 2,4 mm
- Ø 3,2 mm
- Ø 4,0 mm
- Ø 4,8 mm
- Ø 6,4 mm



Br. 24017
specifikacija 280 mm



1



FESTA

KLJEŠTA ZA POP NITNE

Cr-Mo

- Ø 2,4 mm
- Ø 3,2 mm
- Ø 4,0 mm
- Ø 4,8 mm
- Ø 6,4 mm



Br. 24015
specifikacija 530 mm



1



FESTA

KLJEŠTA ZA POP NITNE

Cr-Mo

- Ø 2,4 mm
- Ø 3,0 mm
- Ø 3,2 mm
- Ø 4,0 mm
- Ø 4,8 mm



Br. 24030
specifikacija 260 mm



24



FESTA

KLJEŠTA ZA POP NITNE

- Podesiva glava klješta
- 2 pozicije

Cr-Mo



Br. 24002
specifikacija 260 mm



6

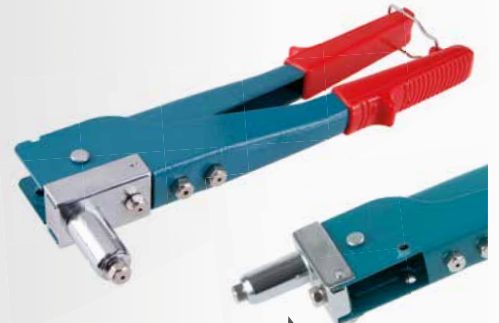

FESTA

KLJEŠTA ZA POP NITNE

Cr-Mo

- Ø 2,4 mm
- Ø 3,2 mm
- Ø 4,0 mm
- Ø 4,8 mm



Br. 24006
specifikacija 250 mm



12



KLJEŠTA ZA POP NITNE KOMPLET

Cr-Mo

- Ø 2,4 x 6 mm
- Ø 3,2 x 6 mm
- Ø 4,0 x 6 mm
- Ø 4,8 x 6 mm



Br. 24005
specifikacija 260 mm



5



FESTA

KLJEŠTA ZA POP NITNE SA OKRENUTOM GLAVOM

Cr-Mo



Br. 24020
specifikacija 290 mm



8



KLJEŠTA ZA POP NITNE



Br. 24001
specifikacija 260 mm



6



KLJEŠTA ZA POP NITNE



Br. 24000
specifikacija 250 mm



24

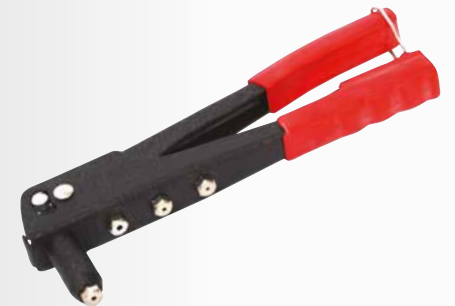

FESTA

KLEŠTA ZA POP NITNE PROFI SA MATICAMA

Cr-Mo

- M3
- M4
- M5
- M6
- M8
- M10



Br.	specifikacija
24036	330 mm



1

FESTA

KLEŠTA ZA POP NITNE PROFI SA MATICAMA

Cr-Mo

- M3
- M4
- M5
- M6



Br.	specifikacija
24035	200 mm



1

FESTA

DELOVI ZA KLEŠTA ZA NITNE

· Pogodan za 24035, 24036

Cr-Mo



Br.	specifikacija	
24038	M3	1
24039	M4	1
24040	M5	1
24041	M6	1
24042	M8	1
24043	M10	1



MATICE ZA NITNE, 20 KOM

ALU

20x



Br.	specifikacija	
23950	M3 x 9 mm	20
23951	M4 x 11 mm	20
23952	M5 x 12 mm	50
23953	M6 x 14 mm	50
23954	M8 x 16,5 mm	25
23955	M10 x 18 mm	20

AL NITNE

ALU

50x



Br.	specifikacija	
23970	3,2 x 6 mm	25
23971	3,2 x 8 mm	25
23972	3,2 x 10 mm	25
23973	3,2 x 12 mm	25
23974	3,2 x 14 mm	25
23975	4,0 x 6 mm	25
23976	4,0 x 8 mm	25
23977	4,0 x 10 mm	25
23978	4,0 x 12 mm	25
23979	4,0 x 14 mm	25
23985	4,8 x 6 mm	25
23986	4,8 x 8 mm	25
23987	4,8 x 10 mm	25
23988	4,8 x 12 mm	25
23989	4,8 x 14 mm	25

**FESTA**

KLJEŠTA ZA POP NITNE



Br.	specifikacija	
17187	350 mm	6

**FESTA**

KLJEŠTA ZA POP NITNE



Br.	specifikacija	
17188	250 mm	12



KLJEŠTA ZA POP NITNE

Br.	specifikacija	
17189	255 mm	12



IZVLAKAČ – RADAPCIGER DVOGLAVI



Br.	mak. prečnika	depth	
23734	Ø 100 mm	50-95 mm	1
23735	Ø 150 mm	100-150 mm	1
23736	Ø 200 mm	110-190 mm	1



IZVLAKAČ – RADAPCIGER TROGLAVI



Br.	mak. prečnika	depth	
23730	Ø 100 mm	50-95 mm	2
23731	Ø 150 mm	100-150 mm	2
23732	Ø 200 mm	110-190 mm	2

**FESTA****INVERTER ZA ZAVARIVANJE TIG/MMA 160 A**

Voltaža / frekvencija	230 V / 50 Hz
Voltaža naprédno	55 V
Regulativni domet zavarivanje struja	10 - 160 A
Prečnik elektrode	1,5 - 4,0 mm
Radni ciklus	TIG- 160 A / 60%, MMA - 140 A / 60%
Klasa zaštite	IP 21
Vrsta zavarivanja	TIG/MMA
Dimenzije	405 x 165 x 270 mm
Tehnologija	Anti-stick, Arc-force, Hot start, Lift TIG
Težina maca	6 kg

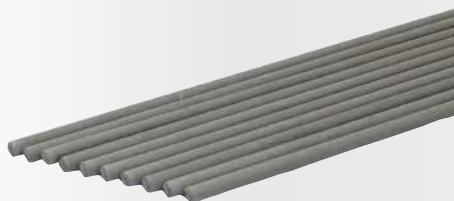

Br.	specifikacija	
70040	Inverter za zavarivanje	1
70045	Rezervni kablovi za zavarivanje	1
70046	Rezervna gorionika TIG	1

**ELEKTRODA RUTIL ER 117**

· Certifikovan

Br.	specifikacija	mnoštvi	
70021	Ø 2,0 x 300 mm	10 kom.	1
70020	Ø 2,0 x 300 mm	2,5 kg	8
70026	Ø 2,5 x 300 mm	10 kom.	1
70025	Ø 2,5 x 300 mm	2,5 kg	8
70033	Ø 3,2 x 350 mm	10 kom.	1
70032	Ø 3,2 x 350 mm	5 kg	4

ELEKTRODA BASIC

· Certifikovan

Br.	specifikacija	mnoštvi	
70030	Ø 2,0 x 300 mm	2,5 kg	1
70031	Ø 2,0 x 300 mm	5 kg	1
70035	Ø 2,5 x 300 mm	2,5 kg	8
70036	Ø 2,5 x 300 mm	10 kom.	1
70037	Ø 3,2 x 350 mm	5 kg	5
70038	Ø 3,2 x 350 mm	10 kom.	1

**FESTA**

SAMOZATAMNUJUĆA MASKA ZA ZAVARIVANJE

veličina vidnog polja	98 x 80 mm
brzina zatamnjenja filtera	1/25 000 s
zatamnjenje filtera	DIN 5-8 / 9-13
UV / IR zaštita	DIN 16
optička klasa	1 1 1 1 2
broj senzora	4
napajanje	Solarna ćelija + baterija CR2450
režim rada	Zavarivanje, brušenje

LCD display

**CE EN**
379

Br.	specifikacija	
70064	aktivan	1
70066	zamena poklopnog stakla	1

**FESTA**

SAMOZATAMNUJUĆA MASKA ZA ZAVARIVANJE



Br.	specifikacija	
70063	aktivan	4



SAMOZATAMNUJUĆA MASKA ZA ZAVARIVANJE

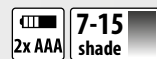

Br.	specifikacija	
70060	aktivan	4



MASKA ZA ZAVARIVANJE



Br.	specifikacija	
70061	aktivan	4



NAOČARE ZA ZAVARIVANJE



Br.	specifikacija	
70062	aktivan	1



REZ. DELOVI STEKLO ZA VARENJE

2x

Br.	specifikacija	
70065	113 x 80 mm	20



VARILAČKI ČEKIĆ



Br.	specifikacija	
19115	300 g	1



KLEŠTA ZA ZAVARIVANJE



Br.	specifikacija	
70070	300 A	1



KLJEŠTA ZA MASU



Br.	specifikacija	
70075	300 A	1



FESTA

MAGNET ZA ZAVARIVANJE UGAONI



Br.	specifikacija	nosnost	
70096	150 x 130 x 30 mm · 45°, 90°, 135°	25 kg	10



MAGNET ZA ZAVARIVANJE UGAONI



Br.	specifikacija	nosnost	
70090	85 x 85 mm · 45°, 90°	9 kg	10



MAGNET ZA ZAVARIVANJE UGAONI



Br.	specifikacija	nosnost	
70093	95 x 64 mm · 30°, 45°, 60°, 75°, 90°	9 kg	10
70094	120 x 90 mm · 30°, 45°, 60°, 75°, 90°	18 kg	10
70095	137 x 110 mm · 30°, 45°, 60°, 75°, 90°	27 kg	10



MAGNET ZA ZAVARIVANJE UGAONI



Br.	specifikacija	nosnost	
70091	95 x 109 x 25 mm · 45°, 90°, 135°	13 kg	10
70092	130 x 150 x 32 mm · 45°, 90°, 135°	22 kg	5



NAVOJNA ŠIPKA

DIN 976 INOX

4.8 · Klasa tvrdoće

Br.	specifikacija	
55311	M 5 1 m	150
55313	M 8 1 m	50
55314	M 10 1 m	25
55315	M 12 1 m	20
55316	M 14 1 m	15
55317	M 16 1 m	15
55318	M 18 1 m	10
55319	M 20 1 m	10

NAVOJNA ŠIPKA

DIN 975 Zn

4.8 · Klasa tvrdoće

Br.	specifikacija	
55040	M 4 1 m	200
55050	M 5 1 m	150
55060	M 6 1 m	100
55080	M 8 1 m	50
55100	M 10 1 m	20
55120	M 12 1 m	20
55140	M 14 1 m	15
55160	M 16 1 m	15
55180	M 18 1 m	10
55200	M 20 1 m	10
55220	M 22 1 m	5
55240	M 24 1 m	5
55300	M 30 1 m	5

NAVOJNA ŠIPKA

DIN 975

4.8 · Klasa tvrdoće

Br.	specifikacija	
55041	M 4 1 m	200
55051	M 5 1 m	150
55181	M 18 1 m	10
55201	M 20 1 m	10
55221	M 22 1 m	5
55301	M 30 1 m	5

NEW



before after



FESTA

SREDSTVO ZA ČIŠĆENJE IVICA

Ø 3 – 19 mm

1/4"



Br. Specifikacija

16321

5



MATICE

DIN 934 Zn

4.8 · Klasa tvrdoće

Br.	specifikacija	
55350	M 4	100 kom. 1
55351	M 5	100 kom. 1
55352	M 6	100 kom. 1
55353	M 8	100 kom. 1
55354	M 10	100 kom. 1
55355	M 12	100 kom. 1
55356	M 14	100 kom. 1
55357	M 16	100 kom. 1
55358	M 18	100 kom. 1
55359	M 20	10 kom. 1
55360	M 22	10 kom. 1
55361	M 24	10 kom. 1
55362	M 30	10 kom. 1



PODLOŠKE

DIN 440R Zn



Br.	specifikacija	
55331	M 5	100 kom. 1
55332	M 6	100 kom. 1
55333	M 8	100 kom. 1
55334	M 10	100 kom. 1
55335	M 12	100 kom. 1
55336	M 14	100 kom. 1
55337	M 16	100 kom. 1
55339	M 20	10 kom. 1
55340	M 22	10 kom. 1
55341	M 24	10 kom. 1
55342	M 30	10 kom. 1



**FESTA****KOMPRESOR 6 L - BEZ ULJA**

Voltaža / frekvencija	230 V / 50Hz
Potrošnja struje	1,2 kW (1,5HP)
Volumen spremnika	6 l
Makom. pritisak	8 Bar
Brzina	3900 min.
Usisna snaga	180 l/min.
Performanse punjenja	116 l/min.
Težina	10 kg



Br.

35360

1

**KOMPRESOR 24 L - BEZ ULJA**

Učinek	1100 W
Voltaža / frekvencija	230 V / 50Hz
Pokreni bez opterećenja	2850 min ⁻¹
Radni pritisak	8 bar
Usis vazduha	160 l / min
Tip	without oil / Безмаслен
Volumen spremnika	24 L
Težina	23 kg



Br.

specifikacija

35361 1,1 kW, 24 l

1

**KOMPRESOR 24 L**

Učinek	1500 W
Voltaža / frekvencija	230 V / 50Hz
Pokreni bez opterećenja	2850 min ⁻¹
Radni pritisak	8 bar
Usis vazduha	200 l / min
Tip	oil / Маслен
Volumen spremnika	24 L
Težina	24 kg



Br.

specifikacija

35362 1,5 kW, 24 l

1

**FESTA**

KOMPLET ALATA ZA KOMPRESOR VEĆI

5x

1. Pištolj raspršivač
2. Pistolj na pritisak sa meracem
3. Pištolj raspršivač
4. Udarni pistolj
5. Spiralno crevo sa priključcima



Br. specifikacija
48001

1

FESTA

KOMPLET ALATA ZA KOMPRESOR MANJI

3x

1. Pistolj na pritisak sa meracem
2. Udarni pistolj
3. Spiralno crevo sa priključcima



Br. specifikacija
48002

1



800 ml

FESTA

PIŠTOLJ RASPRŠIVAČ ZA KOMPRESOR



Br. specifikacija
48015 Donji

1

**FESTA**

PIŠTOLJ ZA PUKOTINE I OTVORE – ZA KOMPRESOR



Ø 1,4 mm



Br. specifikacija
48036 Donji

1



500 ml

FESTA

PNEUMATSKI PIŠTOLJ ZA FARBANJE

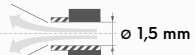

Br.	specifikacija	
48020	Gornji	1



600 ml

FESTA

PNEUMATSKI PIŠTOLJ ZA FARBANJE

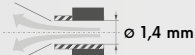

Br.	specifikacija	
48021	Gornji	1
48047	Mlaznica Ø 1,7 mm	1



1000 ml

FESTA

PNEUMATSKI PIŠTOLJ ZA FARBANJE

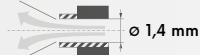

Br.	specifikacija	
48022	Gornji	1
48046	Mlaznica Ø 1,5 mm	1



600 ml

FESTA

PNEUMATSKI PIŠTOLJ SA NASTAVCIMA



Br.	specifikacija	
48030	Donji	1



PIŠTOLJ ZA PRSKANJE BOJA I MALTERA

- 4 - 6 Bar
- 5 l
- Mlaznica Ø 4; 6; 8 mm



Br.	specifikacija	
48037		1



FESTA

PNEUMATSKI PIŠTOLJ KRAČI



Br.	specifikacija	
48005	Kratki	25



FESTA

PNEUMATSKI PIŠTOLJ SREDNJI



Br.	specifikacija	
48006	Srednja	25



FESTA

PNEUMATSKI PIŠTOLJ DUŽI



Br.	specifikacija	
48007	Dugo	25

**FESTA®**PIŠTOLJ ZA PRITISAK SA
MERAČEM

Br.	specifikacija	
48010		1

**FESTA®**SPIRALNO CREVO ZA VAZDUH SA
PRIKLJUCCIMA

· max. 20 Bar

Br.	specifikacija		
48031	5 m	ø 9/15 mm	1
48032	10 m	ø 9/15 mm	1
48033	15 m	ø 9/15 mm	1
48034	20 m	ø 9/15 mm	1

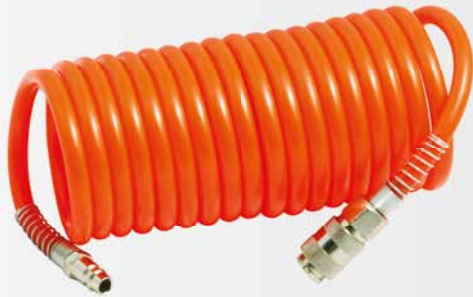
**FESTA®**SPIRALNO CREVO ZA VAZDUH SA
PRIKLJUCCIMA

Br.	specifikacija		světlost	
48043	5 m	8 atm	10 mm	1

**FESTA®**SPIRALNO CREVO ZA VAZDUH SA
PRIKLJUCCIMA

Br.	specifikacija		světlost	
48040	5 m	8 atm	8 mm	1
48041	10 m	8 atm	8 mm	1
48042	15 m	8 atm	8 mm	1

**FESTA®**

FILTER

· Max. 10 bar



Br.	specifikacija	
48008	G 1/4"	1

**FESTA®**REGULATOR PRITISKA
SA MANOMETROM

· 0 - 10 bar



Br.	specifikacija	
48009	G 1/4"	1

**FESTA®**

REZERVNE MLAZNICE

· Za 48021

Br.	specifikacija	
48047	Mlaznica Ø 1,7 mm	1

**FESTA®**

REZERVNE MLAZNICE

· Za 48022

Br.	specifikacija	
48046	Mlaznica Ø 1,5 mm	1

TABELA MERA CEVNIH WHITWORTH NAVOJA

VELIČINA NAVOJA G U PALCIMA	MAKOMIMALNI VANJSKI Ø NAVOJA U MM
1/8	9,728
1/4	13,157
3/8	16,662
1/2	20,955
3/4	26,441
1	33,249



PNEUMATSKE SPOJNICE

Br.	specifikacija	
48075	1/4' spolja	10
48076	3/8' spolja	10
48077	1/2' spolja	10
48095	1/4' unutra	10
48096	3/8' unutra	10
48097	1/2' unutra	10



PNEUMATSKA SPOJNICA

Br.	specifikacija	
48070	1/4' - 6 mm	10
48071	3/8' - 9 mm	10
48072	1/2' - 13 mm	10



PNEUMATSKI ADAPTER

Br.	specifikacija	
48080	1/4' spolja	10
48081	3/8' spolja	10
48090	3/8' unutra	10
48091	1/4' unutra	10

ADAPTER – REDUKTOR

Br.	specifikacija	
48054	3/8' spolja x 1/4' unutra	10
48055	1/2' spolja x 3/8' unutra	10
48056	Umanjenje 3/8' spolja x 1/2' unutra	10
48057	Umanjenje 1/4' spolja x 3/8' unutra	10

ADAPTER – REDUKTOR

Br.	specifikacija	
48050	Spolja 1/4' spolja x 1/4' spolja	10
48051	Umanjenje 1/4' spolja x 3/8' spolja	10



PNEUMATSKA SPOJNICA

Br.	specifikacija	
48085	1/4' - 6 mm	10
48086	3/8' - 9 mm	10
48087	1/2' - 13 mm	10



PNEUMATSKI ADAPTER

Br.	specifikacija	
48060	Ø 6 mm - 1/8' spolja	10
48061	Ø 6 mm - 1/4' spolja	10
48062	Ø 6 mm - 3/8' spolja	10
48063	Ø 9 mm - 1/4' spolja	10
48064	Ø 9 mm - 3/8' spolja	10
48065	Ø 13 mm - 1/4' spolja	10
48066	Ø 13 mm - 3/8' spolja	10
48067	Ø 6 mm - 3/8' unutra	10
48068	Ø 9 mm - 3/8' unutra	10
48093	Ø 6 mm - 1/4' unutra	10
48094	Ø 9 mm - 1/4' unutra	10



ZAŠTITNA OPREMA



ZAŠTITNE NAOČARE

CE EN
166

Br. specifikacija
50510



10



ZAŠTITNE NAOČARE

CE EN
166

Br. specifikacija
50514



10



ZAŠTITNE NAOČARE

 Podesimo dužina drškama

CE EN
166

Br. specifikacija
50511



12



ZAŠTITNE NAOČARE

CE EN
170

Br. specifikacija
50512 tamne



12



ZAŠTITNE NAOČARE

CE EN
166

Br. specifikacija
50513



1



ZAŠTITNE SLUŠALICE

CE EN 352 27 dB

Br. specifikacija
50563

1



ZAŠTITNE SLUŠALICE

CE EN 352 27 dB

Br. specifikacija
50564

1



ZAŠTITNA MASKA ZA LICE

CE EN 166

Br. specifikacija
50556

10



ZAŠTITNI ŠLEM CLIMAX

CE EN 397

MADE IN EU

Br.	specifikacija	
50550	Plav	30
50551	Crvena	30
50553	Bijela	30
50554	Žuta	30



ZAŠTITNA MASKA ZA LICE

CE EN 1731

Br. specifikacija
50562

10



REFLEKTUJUĆI PRSLUK

CE EN 20471

Br.	specifikacija	
50570	Narandžasti	100
50571	Žuti	100



ŠTITNICI ZA UŠI

Br. specifikacija
50560

100



ŠTITNICI ZA UŠI

Br. specifikacija
50559

100



MASKA ZAŠTITNA

CE EN
149

Br.	specifikacija	
50500	FFP2 without valve	30
50501	FFP1 without valve	30



MASKA ZAŠTITNA

CE EN
149

Br.	specifikacija	
50502	FFP1 with valve	20
50503	FFP2 with valve	20



MASKA ZA LICE

50x

Br.	specifikacija	
50505		40

MOQ
40



RUKAVICE KOŽNE OJACANE

· Sa oblogom na dlanu

CE EN
166



Br.	specifikacija	
50518	Veličina 11"	12



RUKAVICE KOŽNE OJACANE

· Sa oblogom na dlanu

CE EN
388



Br.	specifikacija	
50519	Veličina 10,5"	12



KOŽNE RUKAVICE

CE EN
388



Br.	specifikacija	
50520	Veličina 10,5"	12



KOŽNE RUKAVICE

CE EN
388



Br.	specifikacija	
50521	Veličina 10,5"	12



ZIMSKE KOŽNE RUKAVICE

CE EN
388



Br.	specifikacija	
50523	Veličina 11"	12



PAMUČNE RUKAVICE SA PVC TAČKICAMA

Br.	specifikacija	
50524	Veličina 10"	12



**PAMUČNE RUKAVICE
MOCENE U PVC**

CE EN
388

Br.	specifikacija	
50525	Veličina 10" - délka 35 cm	12



**RUKAVICE POLYESTER SA
PVC TAČKICAMA**

· Sa PVC terčikama

Br.	specifikacija	
50526	Veličina 10"	12



**PAMUČNE RUKAVICE SA
LATEX SLOJEM**

CE EN
388

Br.	specifikacija	
50522	Veličina 10"	12



NAJLON NITRILNE RUKAVICE

CE EN
388

Br.	specifikacija	
50533	Veličina 10"	12



**NAJLON RUKAVICE PREMAZANE
LATEX PENOM**

· Sa PVC terčikama

Br.	specifikacija	
50537	Veličina 10"	12



**NAJLON RUKAVICE PREMAZANE
NITRIL PENOM**

CE EN
388

Br.	specifikacija	
50539	Veličina 10"	12



**AKRILNE ZIMSKE RUKAVICE
PRESVUČENELATEXOM**

CE EN
388

Br.	specifikacija	
50529	Veličina 10"	12



RUKAVICE

Br.	specifikacija	
50557	Veličina 7"	12
50558	Veličina 8"	12
50549	Veličina 9"	12



**PAMUČNE RUKAVICE SA
PVC TAČKICAMA**

· Sa PVC terčikama

Br.	specifikacija	
50531	Veličina 9"	12



NAJLON RUKAVICE OD KOZIJE KOŽE



Br.	specifikacija	
50541	Veličina 9"	12
50542	Veličina 10"	12



NAJLON RUKAVICE OD SVINJSKE KOŽE



Br.	specifikacija	
50544	Veličina 10"	12



NAJLONSKE RUKAVICE UMOČENA U POLIURETAN



Br.	specifikacija	
50527	Veličina 10"	12



KOŽNE RUKAVICE ZA ZAVARIVANJE



Br.	specifikacija	
50540	Veličina 11"	12



JEDNOKRATNE VINYL RUKAVICE

bistro, bez praha



Br.	specifikacija	
50532	Veličina 9"	100



ZAŠTITNI KOMBINEZON SA KAPULJACOM

Br.	specifikacija	
50585	Veličina M	1
50586	Veličina L	1
50587	Veličina XL	1
50588	Veličina XXL	1



ZÁSTĚRA NA SVAŘOVÁNÍ



Br.	specifikacija	
50555	Koža	1



FESTA

ZAŠTITNA KOLICA ZA KOLENA

ŠTITNIK ZA KOLENA



Br.	specifikacija	
37135		1

Br.	specifikacija	
37145	gel	8



FESTA

ŠTITNIK ZA KOLENA



FESTA

ŠTITNIK ZA KOLENA



FESTA

ŠTITNIK ZA KOLENA



Br.	specifikacija	
37140	gel	12

Br.	specifikacija	
37144	gel	12

Br.	specifikacija	
37143		12



FESTA

ŠTITNIK ZA KOLENA



ŠTITNIK ZA KOLENA



ŠTITNIK ZA KOLENA



Br.	specifikacija	
37142	komfort	20

Br.	specifikacija	
37139	neopren	10

Br.	specifikacija	
37141		6

· Kvalitetna metalna ručka sa podstavom

· Remen sa čičkom za nošenje dugih alata.

· Udoban remen za odvajanje ramena

· Vyztužená vnútra konštrukce

· 18 džepovima

FESTA

TORBA ZA ALAT SA METALNOM RUČKOM

Br.	visina	dužina	dubina	
37331	280 mm	490 mm	230 mm	2



FESTA

TAŠKA

Br.	širina	visina	dubina	
37332	480 mm	290 mm	250 mm	1



FESTA

TORBA ZA ALAT

Br.	širina	visina	dubina	
37330	610 mm	400 mm	270 mm	5



FESTA

POJAS ZA ALAT

· Ojačani džepovi



Br. specifikace
37325

10



FESTA

POJAS ZA ALAT

· Ojačani džepovi



Br. specifikace
37326

12



FESTA

KAIŠ

Br. specifikace
37328 145 cm



20



FESTA[®]

**FESTO**

PLANINARSKI KAIŠ

· 14 džepovima + oko

Br.	délka	šírka
37311	120 cm	6 cm



1

**FESTO**

POJAS ZA ALAT

· 8 džepovima

Br.	šírka	výška
37320	300 mm	250 mm



1

**FESTO**

POJAS ZA ALAT

· 4 džepovima

Br.	šírka	výška
37321	350 mm	300 mm



1

**FESTO**

KAIŠ NAJLONSKI

Br.	délka	šírka
37310	120 cm	6 cm



1

**FESTO**

RADNIČKA JAKNA ZA ALAT

Br.	specifikace
37350	



20

**FESTA**

POJAS ZA ALATE KOŽA



Br.	specifikacija	
37302	6 džepovima	50
37303	11 džepovima	25



POJAS ZA ALATE KOŽA

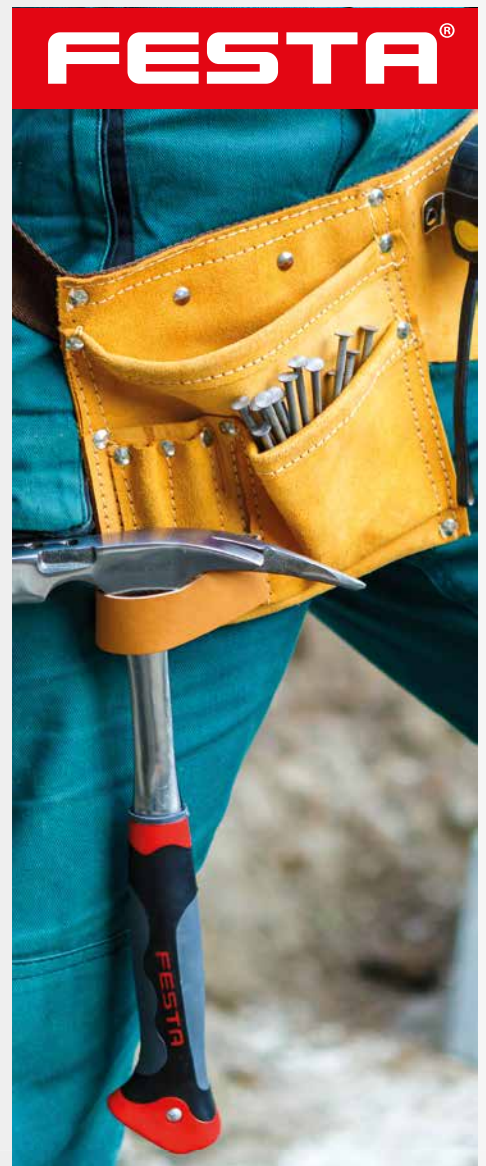

Br.	specifikacija	
37300	6 džepovima	50
37301	11 džepovima	25

**FESTA**[®]

TORBA ZA ALAT KOŽNA PROFI



Br.	vyška	délka	dubina	
37342	270 mm	430 mm	180 mm	1



TORBA ZA ELEKTRIČARE KOŽNA PROFI



Br.	vyška	délka	dubina	
37341	260 mm	430 mm	200 mm	1



TORBA ZA ALAT KOŽNA SA OJAČANIM DNOM



Br.	výška	délka	dubina	
37340	240 mm	430 mm	150 mm	1



TORBA ZA ALAT

Br.	výška	délka	dubina	
37344	250 mm	300 mm	130 mm	1



TORBA ZA ALAT SA OJAČANIM DNOM

Br.	výška	délka	dubina	
37343	240 mm	430 mm	150 mm	1



TORBA ZA ELEKTRIČARE

Br.	výška	délka	dubina	
37345	270 mm	430 mm	180 mm	1



DRŽAČ ALATA „O“



Br.	specifikacija	
37308		20



DRŽAČ ALATA „U“



Br.	specifikacija	
37309		20

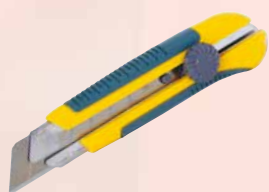

162

SKALPERI I SEČIVO KDS



164

SKALPERI I SEČIVO FESTA



170

STRUGAČI



171

REZERVNO SEČIVO

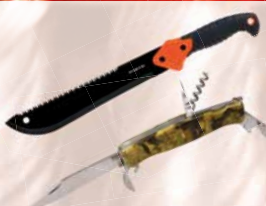

173

PEROREZ



178

REZAČ ZA CEVI I MAKAZE ZA PVC CEVI



181

ELEKTRIČNI REZAČ
STIROPORA

184

BURGIJE ZA METAL



194

SEKAČI, TESTERA ZA
IZREZIVANJE RUPA

198

DIJAMANTNA KRUNA ZA
IZREZIVANJE RUPA

204

BURGIJA ZA DRVO, FREZER,



208

GLAVA ZA BUŠILICU

ALAT ZA SEČENJE

160 - 241



210

BRUSNE ČETKE,



214

BRUSNI PAPIR



219

TURPIJE ZA GIPS KARTON



220

TURPIJE



222

UBODNE TESTERICE,



225

UBODNE TESTERICE,



228

RUCNE TESTERE



234

DIAMANT REZNE PLOČE



238

REZNE I BRUSNE PLOČE

KDS®

Noževi japanske firme KDS

- Izvrsna ergonomska drška
- Visokokvalitetne i dugotrajne oštrice
- Najbolji korišteni materijali u izradi
- Mali otpor rezanja omogućuje lagano rezanje

KDS® SKALPER



Br.	Specifikacija		
16002	LC405	18 mm zeleni	25
16011	LB10	Rezervno sečiva	10



KDS® SKALPER



Br.	Specifikacija		
16003	G11	18 mm + 2 sečiva	10
16012	GB10	Rezervno sečiva	10



KDS® SKALPER



Br.	Specifikacija		
16019	LI9	18 mm + 2 sečiva	10
16011	LB10	Rezervno sečiva	10
16012	GB10	Rezervno sečiva	10





KDS®
SKALPER



Br.	Specifikacija	
16004	H11 25 mm	10
16013	HB10 Rezervno sečiva	10



KDS®
SKALPER



Br.	Specifikacija	
16005	S14 9 mm + 2 sečiva	10
16010	SB10 Rezervno sečiva	10



KDS®
SKALPEL



Br.	Specifikacija	
16006	D12 + 16 sečiva	10



KDS®
REZERVNO SEČIVO KDS



Br.	Specifikacija	
16010	SB10 9 0,38 mm	13 segmenata 20
16011	LB10 18 0,5 mm	15 segmenata 20
16012	GB10 18 0,6 mm	15 segmenata 20
16013	HB10 25 0,7 mm	7 segmenata 10



KDS®
REZERVNO SEČIVO KDS

- Specijalna legura
- Dvoji broušeni
- Poboļššan ųivotni vek
- Niska otpornost na sečenje
- Omogućava lako sečenje



Br.	Specifikacija	
16016	LB10B 18 0,5 mm	8 segmenata 20
16017	HB10B 25 0,7 mm	7 segmenata 10



• ilustracija fotografija

KDS®
REKLAMNA POLICA

- Sadrži 16998 : 16001 · 5 kom
- 16003 · 5 kom
- 16004 · 3 kom
- 16005 · 3 kom
- 16006 · 2 kom
- 16008 · 3 kom
- 16010 · 4 kom
- 16012 · 4 kom
- 16013 · 1 kom
- 16016 · 4 kom
- 16018 · 4 kom
- 16019 · 4 kom
- 16020 · 4 kom

Br.	Specifikacija	
16999	Reklamni stalak	1
16998	Reklamni stalak sa noževima	1



FESTO

FESTO

SKALPER SA KERAMIČKIM SEČIVOM

- 3x sharper than the steel blade
- 10x longer lifetime
- Refractory, non-conductive, non-magnetic



Br.	Specifikacija	
16131	18 mm	10
16066	Rezervno sečivo 18 mm, 5 kom	10



FESTO

SKALPER



Br.	Specifikacija	
16110	L11 18 mm + 1 sečivo	12



FESTO

SKALPER



Br.	Specifikacija	
16100	L12 18 mm + 1 sečivo	12



FESTO

SKALPER



Br.	Specifikacija	
16105	L17 18 mm + 1 sečivo	12



FESTO

SKALPER



Br.	Specifikacija	
16125	L4 9 mm	24
16120	L8 18 mm	24



FESTO

SKALPER



Br.	Specifikacija	
16115	L10 9 mm	24



FESTO

SKALPER

ALU



Br.	Specifikacija	
16150	18 mm	24
16151	18 mm Bez štampanja	20



FESTA

SKALPER

ALU



Br.	Specifikacija	
16136	18 mm	12



FESTA

SKALPER

ALU



Br.	Specifikacija	
16137	25 mm	12



FESTA

SKALPER

• Gumena drška protiv klizanja

+4

ALU



Br.	Specifikacija	
16090	18 mm	12



FESTA

SKALPER

• Gumena drška protiv klizanja

+4

ALU



Br.	Specifikacija	
16091	25 mm	6



FESTA

SKALPER

• Gumena drška protiv klizanja

ALU



Br.	Specifikacija	
16145	L25 18 mm	12



FESTA

SKALPER

• Gumena drška protiv klizanja

ALU



Br.	Specifikacija	
16144	L24 18 mm	12



SKALPER

ALU



Br.	Specifikacija	
16143	18 mm	12



SKALPER

ALU



Br.	Specifikacija	
16142	18 mm	12



SKALPER

ALU



Br. 16025
Specifikacija 18 mm

12



FESTA

SKALPER

ALU



Br. 16029
Specifikacija 18 mm

25



FESTA

SKALPER

• Gumena drška protiv klizanja



Br. 16146
Specifikacija 18 mm

12



FESTA

SKALPER

• Gumena drška protiv klizanja



Br. 16147
Specifikacija 25 mm

12



FESTA

SKALPER

• Gumena drška protiv klizanja



Br. 16130
Specifikacija L18 18 mm + 5 sečivo

12



FESTA

SKALPER

• Gumena drška protiv klizanja



Br. 16135
Specifikacija L20 25 mm + 5 sečivo

6



FESTA

SKALPER

• Gumena drška protiv klizanja



Br. 16140
Specifikacija L22 18 mm

12



FESTA

SKALPER

• Gumena drška protiv klizanja

ALU



Br. 16034
Specifikacija 25 mm

12



FESTA

SKALPER

INOX

Br.	Specifikacija	
16085	9 mm	24



FESTA

SKALPER

INOX

Br.	Specifikacija	
16086	18 mm	24



SIGURNOSNI NOŽ

· samo-uvlačeća sečivo

Br.	Specifikacija	
16057	135 mm	12



FESTA

SIGURNOSNI NOŽ

ALU INOX

Br.	Specifikacija	
16058		6
16074	Rezervno sečivo 10 kom	1



FESTA

SKALPER

+5 ALU

Br.	Specifikacija	
16037	+ 5 sečivo	6



FESTA

SKALPER

+5 ALU

Br.	Specifikacija	
16023	+ 5 sečivo	12
16071	Rezervno sečivo 10 kom	10

FESTA

SKALPER KOMPLET

ALU

Br.	Specifikacija	
16095	25 sečivak	1



**FESTA****SKALPER SA ARETACIJOM**

· Gumena drška protiv klizanja



Br.	Specifikacija
16035	+ 2 sečivo

12

**FESTA****SKALPER SA ARETACIJOM**

Br.	Specifikacija
16033	NP 110 + 3 sečivo

5

**FESTA****SKALPER SA ARETACIJOM**

Br.	Specifikacija
16038	+ 5 sečivo

12

**SKALPER SA ARETACIJOM**

Br.	Specifikacija
16032	NP 109

48

**SKALPER SA ARETACIJOM**

Br.	Specifikacija
16031	NS 107 B

24

**SKALPER**

Br.	Specifikacija
16030	NS 107

24

**NOŽ ZA TEPIH I LINOLEUM**

· za tepih i linoleum



Br.	Specifikacija
16036	45 mm

12

**KUKASTI NOŽ**

· za tepih i linoleum



Br.	Specifikacija
16041	

12



SKALPER

ALU



Br.	Specifikacija	MOQ
16046	18 mm	12



SKALPER

Br.	Specifikacija	MOQ
16028	S 201 18 mm	24



SKALPER

Br.	Specifikacija	MOQ
16026	P 205 18 mm	30



SKALPER

HOBBY

Br.	Specifikacija	MOQ
16021	P 201 9 mm	60



SKALPER

HOBBY

Br.	Specifikacija	MOQ
16024	P 204 18 mm	60



MOQ 24



SKALPER

• Gumena drška protiv klizanja

Br.	Specifikacija	MOQ
16141	18 mm	24



SKALPER KOMPLET

HOBBY

12x

Br.	Specifikacija	MOQ
16053	9 mm	12
16055	18 mm	12



SKALPER KOMPLET

HOBBY

3x



Br.	Specifikacija	MOQ
16043		24



50 mm

STRUGALICA

ALU



Br.	Specifikacija	
16059	50 mm	10
16082	Rezervno sečivo	1



100 mm

STRUGALICA

ALU



· za upotrebu sa oštricama od 18 mm za skalper

Br.	Specifikacija	
16054	100 mm	1



38 mm

FESTA

STRUGALICA

· Gumena drška protiv klizanja



Br.	Specifikacija	
16049		12
16069	Rezervno sečivo	1



10 cm

FESTA

PRODUŽENI STRUGAČ STAKLA



Br.	Specifikacija	
16052	48 cm dužina	6
16070	sečivo	25



60 mm

STRUGALICA



Br.	Specifikacija	
16051		24



55 mm

STRUGALICA



Br.	Specifikacija	
16050		24



SET SCRAPERS ZA PRIMENU I UKLANJANJE SILIKONA

3x



Br.	Specifikacija	
16042		12

FESTA

REZERVNO SEČIVO

- 7 segmenata
- 3x duži životni vek
- duplo brušenje
- mali otpor rezanja

SK2 10x

Br.	Specifikacija
16064	25 0,7 mm



20



REZERVNO SEČIVO

- 7 segmenata

10x

Br.	Specifikacija
16068	25 0,6 mm



20

FESTA

REZERVNO SEČIVO

- 8 segmenata
- 3x duži životni vek
- duplo brušenje
- mali otpor rezanja

SK2 10x

Br.	Specifikacija
16062	18 0,7 mm



10

FESTA

REZERVNO SEČIVO

- 15 segmenata
- 3x duži životni vek
- duplo brušenje
- mali otpor rezanja

SK2 10x

Br.	Specifikacija
16063	18 0,7 mm



10

FESTA

REZERVNO SEČIVO KERAMIČKO

- 8 segmenata
- 3x sharper than the steel blade
- 10x duži životni vek
- Refractory, non-conductive, non-magnetic

5x

Br.	Specifikacija
16066	18 0,6 mm



10

REZERVNO SEČIVO

- 4 segmenata

10x

Br.	Specifikacija
16067	18 0,5 mm



10

REZERVNO SEČIVO

- 8 segmenata

10x

Br.	Specifikacija
16065	18 0,5 mm



60

REZERVNO SEČIVO

- 15 segmenata

10x

Br.	Specifikacija
16081	18 0,5 mm



60

REZERVNO SEČIVO

- 8 segmenata
- Duplo brušenje

10x

Br.	Specifikacija
16078	18 0,5 mm



25



REZERVNO SEČIVO

- 8 segmenata
- Duplo brušenje

10x

Br.	Specifikacija
16077	18 0,6 mm



25





REZERVNO SEČIVO

· 7 segmenata

10x

Br.	Specifikacija	
16061	9 0,4 mm	60



REZERVNO SEČIVO

· 13 segmenata

10x

Br.	Specifikacija	
16060	9 0,45 mm	10



FESTA

REZERVNO SEČIVO

· Za 16058

10x

Br.	Specifikacija	
16074		1



FESTA

REZERVNO SEČIVO

10x



Br.	Specifikacija	
16072	R 004	10



FESTA

REZERVNO SEČIVO

10x



Br.	Specifikacija	
16075	R 003	10



REZERVNO SEČIVO

10x

Br.	Specifikacija	
16071	R 001	60



REZERVNO SEČIVO

10x

Br.	Specifikacija	
16073	R 002	60



REZERVNO SEČIVO

5x

Br.	Specifikacija	
16084	18 mm	50

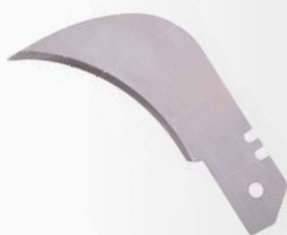

REZERVNO SEČIVO

5x

Br.	Specifikacija	
16083	18 mm	50



REZERVNO SEČIVO

· Za 34315

Br.	Specifikacija	
34316		1



REZERVNO SEČIVO

· Za 16052

Br.	Specifikacija	
16070	100 mm	25



FESTA

LOVAČKI NOŽ

- Najlonska drška
- Sečivo sa teflonskom površinom
- Futrola sa osiguračem i kopčom



Br.	Specifikacija	
16234	21 10 cm	10



FESTA

LOVAČKI NOŽ



Br.	Specifikacija	
16229	23 10 cm	12



FESTA

DLETO MULTIFUNKCIONALNO

- Ojačana sečiva

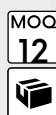

Br.	Specifikacija	
16231	20 8 cm	12



TEHNIČKI NOŽ

- Ojačana sečiva



Br.	Specifikacija	
16230	21 10 cm	12



NOŽ



Br.	Specifikacija	
16022	16 6,5 cm	100



FESTA

NOŽ ZA TEPIHE

Br.	Specifikacija	
16225	20 8,5 cm	12



FESTA

ELEKTRIČARSKI NOŽ

- Ojačana sečiva



Br.	Specifikacija	
16212	15 3,2 cm	12



FESTA

NOŽ ZA SKIDANJE IZOLACIJE

Br.	Specifikacija	
16201	Ø 8 - 27 mm	10

**FESTA**

ELEKTRIČARSKI NOŽ

INOX



Br.	Specifikacija	
16211	20 8,5 cm	10

**FESTA**

ELEKTRIČARSKI NOŽ

INOX



Br.	Specifikacija	
16210	20,5 9 cm	10

**FESTA**

NOŽ ZA KALEMLJENJE

INOX



Br.	Specifikacija	
16219	19 11 cm	24

**FESTA**

NOŽ ZA KALEMLJENJE

INOX



Br.	Specifikacija	
16218	18,5 10,5 cm	24

**FESTA**

NOŽ ZA KALEMLJENJE

INOX



Br.	Specifikacija	
16220	18,5 11 cm	24

**FESTA**

PEROREZ

INOX



Br.	Specifikacija	
16235	17,5 8,5 cm	24

**FESTA**

PEROREZ

INOX



Br.	Specifikacija	
16221	21 12 cm	24

**FESTA**

PEROREZ

INOX



Br.	Specifikacija	
16236	22,5 10 cm	24



· Otvarač za flaše

· Karabina

FESTA

PEROREZ



Br.	Specifikacija
16209	14,5 5,5 cm

1



FESTA

PEROREZ

INOX



Br.	Specifikacija
16222	20 12 cm

24



FESTA

PEROREZ

INOX ALU



Br.	Specifikacija
16223	18,5 10,5 cm

24



FESTA

PEROREZ

· 10 funkcija

INOX



Br.	Specifikacija
16226	17,5 7 cm

24



FESTA

PEROREZ

· 5 funkcija

INOX



Br.	Specifikacija
16228	27 10,5 cm

24



PEROREZ

· 3 funkcija



Br.	Specifikacija
16227	20,5 10 cm

24



PEROREZ

· 7 funkcija

INOX



Br.	Specifikacija
16224	17,5 7 cm

24



FESTA

MULTIFUNKCIONALNE KLIJEŠTA

- 9 funkcija
- Futrola

CrV

Br.	Specifikacija
16232	



12



FESTA

REZAČ MINERALNE VUNE

Br.	Specifikacija
16198	44,5 33 cm



12



FESTA

NOŽ ZA IZOLACIJU

- Nož od mineralne vune, polistiren

Br.	Specifikacija
16199	48 35 cm



10



FESTA

MAČETA

TEFLON

Br.	Specifikacija
45069	440 mm

6



FESTA

MAČETA SA ZUBCIMA

TEFLON

Br.	Specifikacija
44950	490 mm

4



MAČETA ROSTFREI

INOX

Br.	Specifikacija
45083	430 mm
45084	600 mm

12
6



MAČETA

- Drška od jasena

Br.	Specifikacija
45081	510 mm
45082	710 mm

36
36



SKALPELI

23x



24

Br. Specifikacija

16282



SKALPELI

13x



10

Br. Specifikacija

16281



BRUS

Br. Specifikacija

45370

250 x 33 x 18 mm



20

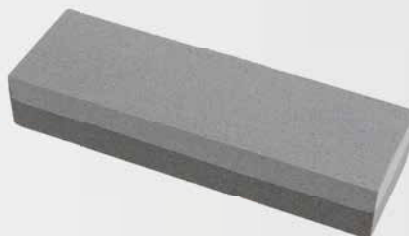

BRUS

Br. Specifikacija

45045

150 x 50 x 30 mm



1



BRUS ZA KOSU

Br. Specifikacija

45046

205 x 15 mm



100



BRUS ZA NOŽEVE I MAKAZE

Br. Specifikacija

16991

20



20



BRUS ZA NOŽEVE I MAKAZE

Br. Specifikacija

16990

Ø 50 mm



1



BRUS ZA NOŽEVE I MAKAZE

Br. Specifikacija

45048

20



20



BRUS ZA NOŽEVE I MAKAZE 6 V 1

Br. Specifikacija

45068

10



10



**FESTA****PEGLA ZA SPAJANJE PVC CEVI SA REGULACIJOM TOPLOTE**

- Napon 230 V / 50 Hz
- Potrošnja energije 750 / 1500 W
- Temperatura 0-300 C°
- Za prečnike Ø 20,25,32,40,50,63 mm
- Težina 1,6 kg



· Sadržaj kompleta: metar, libela, inbus ključ, klešta za cevi, 6 adaptera za lemljenje cevi, metalna kutija



Br.
17182

**FESTA****PEGLA ZA SPAJANJE PVC CEVI SA REGULACIJOM TOPLOTE**

- Napon 230 V / 50 Hz
- Potrošnja energije 800 / 1000 W
- Temperatura 0-300 C°
- Za prečnike Ø 16, 20, 25, 32 mm
- Težina 1 kg



· Sadržaj kompleta: 4 adaptera za lemljenje cevi, 4 adaptera za lemljenje cevi, metalna kutija kufr



Br.
17183





FESTA®

FESTA®

KLJEŠTA ZA PVC CEVI

Ø max.
42 mm



Br.	Specifikacija	
17027		10
16315	Rezervna oštrica	1



REZERVNA OŠTRICA ZA SEKAČ PVC CIJEVI

· Za 17027

Br.	Specifikacija	
16315		1

NEW



FESTA®

KLJEŠTA ZA PVC CEVI

Ø max.
32 mm



Br.	Specifikacija	
17037		12



KLJEŠTA ZA PVC CEVI

Ø max.
42 mm



Br.	Specifikacija	
17026		6



FESTA®

KLJEŠTA ZA PVC PROFIL

· Letvice, cevi, profili

Ø 17 mm Ø 20 mm Ø 27 mm

5x

Br.	Specifikacija	
17050		8





FESTA

REZAČ ZA CEVI

Ø 3-22 mm



Br.	Specifikacija	10
16301		10
16311	Rezervni kotačić	1



FESTA

REZAČ ZA CEVI

Ø 6-64 mm



Br.	Specifikacija	6
16304		6
16312	Rezervni kotačić	1



REZAČ ZA CEVI

Ø 3-32 mm



Br.	Specifikacija	10
16303		10
16311	Rezervni kotačić	1



REZAČ ZA CEVI

Ø 3-32 mm



Br.	Specifikacija	10
16300		10
16310	Rezervni kotačić	1

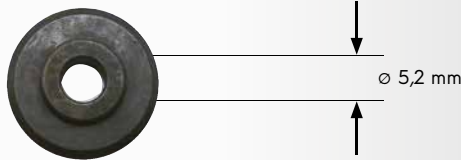

NEW



before after



REZERVNI KOTAČIĆ



CISTAC IVICA

1/4"

Br.	Specifikacija	1
16310	Ø 17,5 mm x 6 m za 16300	1
16311	Ø 18,0 mm x 4,5 mm za 16303, 16301	1
16312	Ø 27,5 mm x 6 mm za 16304	1

Br.	Specifikacija	1
16321		1

PLASTICNI CISTAC IVICA

Ø 6-32 mm

Br.	Specifikacija	1
16320		1



ZAŠILJENI RUČNI NOŽ ZA GLODALICU HSS

1/4" HSS

4x



Br.	Specifikacija	10
20360		10



CISTAC IVICA

Br.	Specifikacija	1
20361		1



FESTA

REZAČ ZA POLISTIRENSKE, BATERIJE

- baterija 36 V, 1,5Ah Li-ion
- potrošnja struje 180 W
- temperature max 350 C°
- dužina rezu 20 cm



· oprema: 2 baterije, punjač, sečivo, mesing četka za čišćenje, šesterokut

Br.	Specifikacija
35323	



FESTA

ELEKTRIČNI REZAČ STIROPORA

- Voltaža 230 V/50 Hz
- Potrošnja struje 250 W
- Temperature 50-600 C°
- Dužina rezu 25 cm
- Dužina kabla za napajanje 3 m



· Oprema: čišćenje četke od mesinga, imbus, nož 25 a 30 cm

Br.	Specifikacija	1
35326	Električni rezač stiropora	1
35328	Rezervni nož za rezač stiropora 14 cm	1
35329	Rezervni nož za rezač stiropora 25 cm	1



VODJICA ZA REZANJE STIROPORA

Br.	Specifikacija	1
35327	Vodilica za rezanje polistirena	1
35335	Rezervni nož - 30 cm	1

FESTA

ELEKTRIČNI REZAČ STIROPORA



· Regulacija temperature

Br.	Specifikacija
35325	220 W



NEW



FESTA

REZAČ STIROPORA

- Voltaža 230 V/50 Hz
- Potrošnja struje 160 W
- Dužina reza 137 cm
- Visina reza 30 cm
- Zaštita IP44
- Ugao rezanja 0° - 90°

· oprema: postolje, nožni prekidač, držač za skele, 2k Ni-Cr žica za sečenje, mesingana četka za čišćenje, alati i pričvršćivači, plastična kutija sa točkovima



Br. Specifikacije

35348



1

NEW



FESTA

NOŽNI PREKIDAČ
ZA REZAČ POLISTIRENA

za 35330, 35345, 35348



Br. Specifikacije

35334

1

NEW



FESTA

STAJATI
ZA REZAČ POLISTIRENA

za 35330, 35345, 35348



Br. Specifikacije

35336

1

NEW



FESTA

ZAMENA OPRUGE
ZA REZAČ POLISTIRENA

za 35330, 35345, 35348



Br. Specifikacije

35332

1

NEW



FESTA

DRŽAČ ZA SKELE
ZA REZAČ POLISTIRENA

za 35330, 35345, 35348



Br. Specifikacije

35333

1

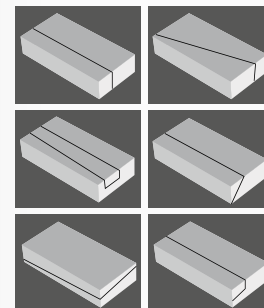
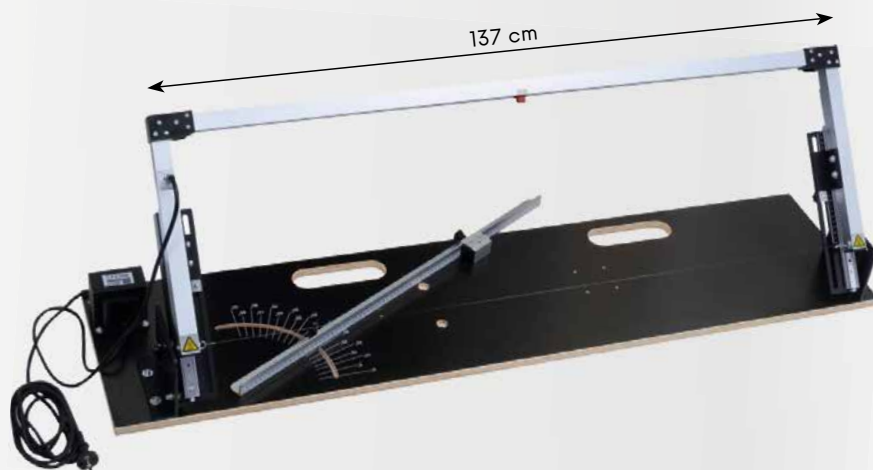

FESTA

REZAČ STIROPORA

- Voltaža **230 V / 50 Hz**
- Potrošnja struje **160 W**
- Dužina reza **137 cm**
- Visina reza **30 cm**
- Zaštita **IP44**
- Ugao rezanja **0° - 90°**



· Oprema: Ni-Cr žica za sečenje, čišćenje četke od mesinga, imbus



Br.	Specifikacije	
35345	Rezač stiropora 1500 x 450 mm	1
35346	Rezervna žica za sečenje Ni-Cr	1
35347	Rezervno napajanje	1

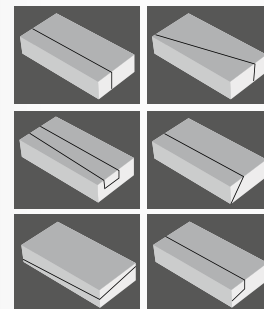
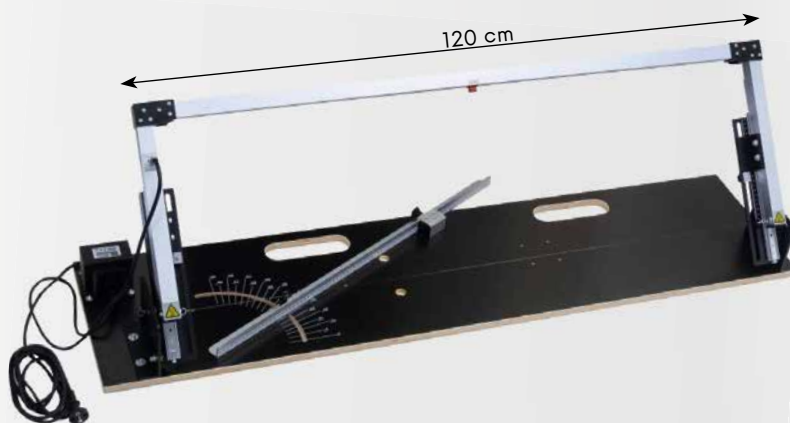

FESTA

REZAČ STIROPORA

- Voltaža **230 V / 50 Hz**
- Potrošnja struje **160 W**
- Dužina reza **120 cm**
- Visina reza **30 cm**
- Zaštita **IP44**
- Ugao rezanja **0° - 90°**



· Oprema: Ni-Cr žica za sečenje, čišćenje četke od mesinga, imbus

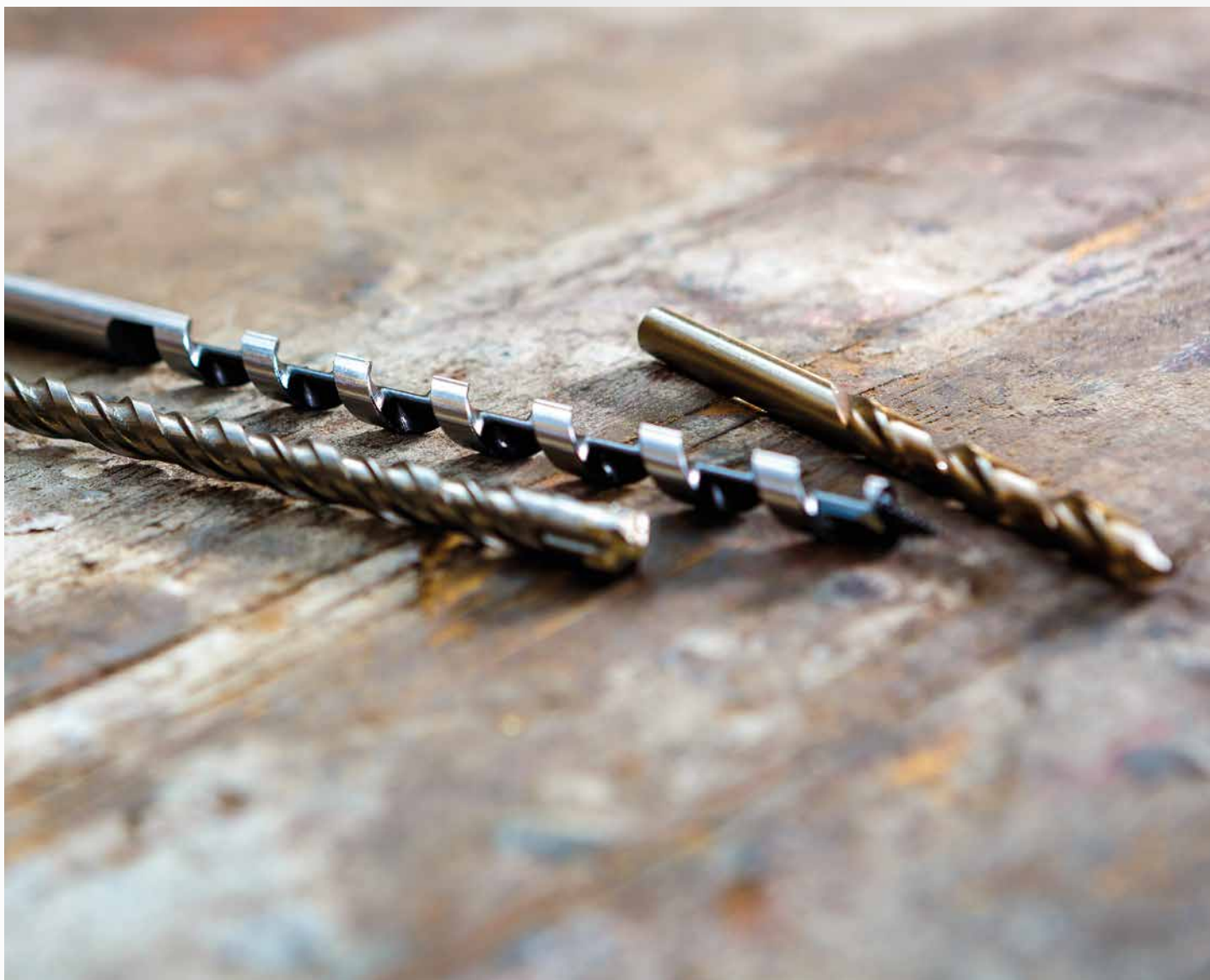

Br.	Specifikacije	
35330	Rezač stiropora 1350 x 450 mm	1
35331	Rezervna žica za sečenje Ni-Cr	1
35347	Rezervno napajanje	1

**FESTA****BURGIJA SPIRALNA HSS-G COBALT 5 %**Co 5%, W 6%
Mo 5%, Cr 4%, V 4%**HSS****DIN**
338**135°****INOX****1400**
MPa

Br.	Specifikacija		Br.	Specifikacija		Br.	Specifikacija	
22510	Ø 1,00 mm	1	22548	Ø 4,80 mm	1	22590	Ø 9,00 mm	1
22515	Ø 1,50 mm	1	22550	Ø 5,00 mm	1	22595	Ø 9,50 mm	1
22520	Ø 2,00 mm	1	22555	Ø 5,50 mm	1	22600	Ø 10,00 mm	1
22525	Ø 2,50 mm	1	22560	Ø 6,00 mm	1	22602	Ø 10,20 mm	1
22530	Ø 3,00 mm	1	22565	Ø 6,50 mm	1	22605	Ø 10,50 mm	1
22532	Ø 3,20 mm	1	22568	Ø 6,80 mm	1	22610	Ø 11,00 mm	1
22535	Ø 3,50 mm	1	22570	Ø 7,00 mm	1	22615	Ø 11,50 mm	1
22540	Ø 4,00 mm	1	22575	Ø 7,50 mm	1	22620	Ø 12,00 mm	1
22542	Ø 4,20 mm	1	22580	Ø 8,00 mm	1	22625	Ø 12,50 mm	1
22545	Ø 4,50 mm	1	22585	Ø 8,50 mm	1	22630	Ø 13,00 mm	1



FESTA

BURGIJA SPIRALNA HSS-G W 9 %

W 9%, Mo 3%
Cr 4%, V 1%

HSS

DIN 338

INOX



1100 MPa

MOQ



Br.	Specifikacija	
19530	Ø 1,00 mm	10
19532	Ø 1,20 mm	10
19533	Ø 1,30 mm	10
19534	Ø 1,40 mm	10
19535	Ø 1,50 mm	10
19536	Ø 1,60 mm	10
19537	Ø 1,70 mm	10
19538	Ø 1,80 mm	10
19539	Ø 1,90 mm	10
19540	Ø 2,00 mm	10
19541	Ø 2,10 mm	10
19542	Ø 2,20 mm	10
19543	Ø 2,30 mm	10
19544	Ø 2,40 mm	10
19545	Ø 2,50 mm	10
19546	Ø 2,60 mm	10
19547	Ø 2,70 mm	10
19548	Ø 2,80 mm	10
19550	Ø 3,00 mm	10
19552	Ø 3,20 mm	10
19553	Ø 3,30 mm	10
19554	Ø 3,40 mm	10
19555	Ø 3,50 mm	10
19556	Ø 3,60 mm	10

Br.	Specifikacija	
19557	Ø 3,70 mm	10
19558	Ø 3,80 mm	10
19559	Ø 3,90 mm	10
19560	Ø 4,00 mm	10
19561	Ø 4,10 mm	10
19562	Ø 4,20 mm	10
19563	Ø 4,30 mm	10
19564	Ø 4,40 mm	10
19565	Ø 4,50 mm	10
19567	Ø 4,70 mm	10
19568	Ø 4,80 mm	10
19569	Ø 4,90 mm	5
19570	Ø 5,00 mm	5
19573	Ø 5,30 mm	5
19574	Ø 5,40 mm	5
19575	Ø 5,50 mm	5
19576	Ø 5,60 mm	5
19577	Ø 5,70 mm	5
19578	Ø 5,80 mm	5
19579	Ø 5,90 mm	5
19580	Ø 6,00 mm	5
19581	Ø 6,10 mm	5
19583	Ø 6,30 mm	5
19584	Ø 6,40 mm	5

Br.	Specifikacija	
19585	Ø 6,50 mm	5
19586	Ø 6,60 mm	5
19587	Ø 6,70 mm	5
19588	Ø 6,80 mm	5
19589	Ø 6,90 mm	5
19590	Ø 7,00 mm	5
19591	Ø 7,10 mm	5
19593	Ø 7,30 mm	5
19594	Ø 7,40 mm	5
19595	Ø 7,50 mm	5
19596	Ø 7,60 mm	5
19597	Ø 7,70 mm	5
19598	Ø 7,80 mm	5
19599	Ø 7,90 mm	5
19600	Ø 8,00 mm	5
19601	Ø 8,10 mm	5
19603	Ø 8,30 mm	5
19604	Ø 8,40 mm	5
19605	Ø 8,50 mm	5
19606	Ø 8,60 mm	5
19607	Ø 8,70 mm	5
19608	Ø 8,80 mm	5
19609	Ø 8,90 mm	5
19610	Ø 9,00 mm	5
19611	Ø 9,10 mm	5
19612	Ø 9,20 mm	5
19613	Ø 9,30 mm	5
19614	Ø 9,40 mm	5
19615	Ø 9,50 mm	3
19616	Ø 9,60 mm	3
19617	Ø 9,70 mm	3
19618	Ø 9,80 mm	3
19619	Ø 9,90 mm	3
19620	Ø 10,00 mm	3
19621	Ø 10,10 mm	3
19622	Ø 10,20 mm	3
19623	Ø 10,30 mm	3
19624	Ø 10,40 mm	3
19625	Ø 10,50 mm	3
19626	Ø 10,60 mm	3

Br.	Specifikacija	
19627	Ø 10,70 mm	3
19628	Ø 10,80 mm	3
19629	Ø 10,90 mm	3
19630	Ø 11,00 mm	3
19631	Ø 11,10 mm	3
19632	Ø 11,20 mm	3
19633	Ø 11,30 mm	3
19634	Ø 11,40 mm	3
19635	Ø 11,50 mm	3
19636	Ø 11,60 mm	3
19637	Ø 11,70 mm	3
19638	Ø 11,80 mm	3
19639	Ø 11,90 mm	3
19640	Ø 12,00 mm	3
19641	Ø 12,10 mm	3
19642	Ø 12,20 mm	3
19643	Ø 12,30 mm	3
19644	Ø 12,40 mm	3
19645	Ø 12,50 mm	3
19646	Ø 12,60 mm	1
19647	Ø 12,70 mm	1
19648	Ø 12,80 mm	1
19649	Ø 12,90 mm	1
19650	Ø 13,00 mm	1
19651	Ø 13,20 mm R13	1
19652	Ø 13,50 mm R13	1
19653	Ø 14,00 mm R13	1
19654	Ø 14,50 mm R13	1
19655	Ø 15,00 mm R13	1
19656	Ø 15,50 mm R13	1
19657	Ø 16,00 mm R13	1
19658	Ø 16,50 mm R13	1
19659	Ø 17,00 mm R13	1
19660	Ø 17,50 mm R13	1
19661	Ø 18,00 mm R13	1
19662	Ø 18,50 mm R13	1
19663	Ø 19,00 mm R13	1
19664	Ø 19,50 mm R13	1
19665	Ø 20,00 mm R13	1



FESTA

BOX - BURGIJA SPIRALNA HSS-G W 9 % - KOMPLET

W 9%, Mo 3%
Cr 4%, V 1%

HSS

DIN 338

INOX



1100 MPa

Br.	Specifikacija	
19669		1
90191	bez burgija	1

Br.	obsah sady	Br.	obsah sady
19530	Ø 1,00 mm 20x	19585	Ø 6,50 mm 15x
19535	Ø 1,50 mm 20x	19590	Ø 7,00 mm 15x
19540	Ø 2,00 mm 20x	19595	Ø 7,50 mm 15x
19545	Ø 2,50 mm 20x	19600	Ø 8,00 mm 15x
19550	Ø 3,00 mm 20x	19605	Ø 8,50 mm 15x
19552	Ø 3,20 mm 20x	19610	Ø 9,00 mm 15x
19555	Ø 3,50 mm 20x	19615	Ø 9,50 mm 15x
19558	Ø 3,80 mm 20x	19620	Ø 10,00 mm 15x
19560	Ø 4,00 mm 30x	19625	Ø 10,50 mm 6x
19562	Ø 4,20 mm 20x	19630	Ø 11,00 mm 6x
19565	Ø 4,50 mm 20x	19635	Ø 11,50 mm 6x
19568	Ø 4,80 mm 20x	19640	Ø 12,00 mm 6x
19570	Ø 5,00 mm 15x	19645	Ø 12,50 mm 6x
19575	Ø 5,50 mm 15x	19650	Ø 13,00 mm 6x
19580	Ø 6,00 mm 30x		

**FESTA****BURGIJA SPIRALNA**W 4%, Mo 3%
Cr 4%, V 1%**HSS****DIN
338****ALU****900
MPa****MOQ**

Br.	Specifikacija	
19670	Ø 0,6 mm	10
19671	Ø 0,8 mm	10
19672	Ø 0,9 mm	10
19673	Ø 1,0 mm	10
19674	Ø 1,1 mm	10
19675	Ø 1,2 mm	10
19676	Ø 1,3 mm	10
19677	Ø 1,4 mm	10
19678	Ø 1,5 mm	10
19679	Ø 1,6 mm	10
19680	Ø 1,7 mm	10
19681	Ø 1,8 mm	10
19682	Ø 1,9 mm	10
19683	Ø 2,0 mm	10
19684	Ø 2,1 mm	10
19685	Ø 2,2 mm	10
19686	Ø 2,3 mm	10
19687	Ø 2,4 mm	10
19688	Ø 2,5 mm	10
19689	Ø 2,6 mm	10
19690	Ø 2,7 mm	10
19691	Ø 2,8 mm	10
19692	Ø 2,9 mm	10
19693	Ø 3,0 mm	10

Br.	Specifikacija	
19694	Ø 3,1 mm	10
19695	Ø 3,2 mm	10
19696	Ø 3,3 mm	10
19697	Ø 3,4 mm	10
19698	Ø 3,5 mm	10
19699	Ø 3,6 mm	10
19700	Ø 3,7 mm	10
19701	Ø 3,8 mm	10
19702	Ø 3,9 mm	10
19703	Ø 4,0 mm	10
19704	Ø 4,1 mm	10
19705	Ø 4,2 mm	10
19706	Ø 4,3 mm	10
19707	Ø 4,4 mm	10
19708	Ø 4,5 mm	10
19709	Ø 4,6 mm	10
19710	Ø 4,7 mm	10
19711	Ø 4,8 mm	10
19712	Ø 4,9 mm	10
19713	Ø 5,0 mm	10
19714	Ø 5,1 mm	10
19715	Ø 5,2 mm	10
19716	Ø 5,3 mm	10
19717	Ø 5,4 mm	10

Br.	Specifikacija		Br.	Specifikacija	
19718	Ø 5,5 mm	10	19760	Ø 9,7 mm	5
19719	Ø 5,6 mm	10	19761	Ø 9,8 mm	5
19720	Ø 5,7 mm	10	19762	Ø 9,9 mm	5
19721	Ø 5,8 mm	10	19763	Ø 10,0 mm	5
19722	Ø 5,9 mm	10	19764	Ø 10,1 mm	5
19723	Ø 6,0 mm	10	19765	Ø 10,2 mm	5
19724	Ø 6,1 mm	10	19766	Ø 10,3 mm	5
19725	Ø 6,2 mm	10	19767	Ø 10,4 mm	5
19726	Ø 6,3 mm	10	19768	Ø 10,5 mm	5
19727	Ø 6,4 mm	10	19769	Ø 10,6 mm	5
19728	Ø 6,5 mm	10	19770	Ø 10,7 mm	5
19729	Ø 6,6 mm	10	19771	Ø 10,8 mm	5
19730	Ø 6,7 mm	10	19772	Ø 11,0 mm	5
19731	Ø 6,8 mm	10	19773	Ø 11,2 mm	5
19732	Ø 6,9 mm	10	19774	Ø 11,3 mm	5
19733	Ø 7,0 mm	10	19775	Ø 11,4 mm	5
19734	Ø 7,1 mm	10	19776	Ø 11,5 mm	5
19735	Ø 7,2 mm	10	19777	Ø 11,6 mm	5
19736	Ø 7,3 mm	10	19778	Ø 11,7 mm	5
19737	Ø 7,4 mm	10	19779	Ø 11,8 mm	5
19738	Ø 7,5 mm	10	19780	Ø 11,9 mm	5
19739	Ø 7,6 mm	10	19781	Ø 12,0 mm	5
19740	Ø 7,7 mm	10	19782	Ø 12,2 mm	5
19741	Ø 7,8 mm	10	19783	Ø 12,5 mm	5
19742	Ø 7,9 mm	10	19784	Ø 12,8 mm	5
19743	Ø 8,0 mm	10	19785	Ø 12,9 mm	5
19744	Ø 8,1 mm	10	19786	Ø 13,0 mm	5
19745	Ø 8,2 mm	10	19787	Ø 13,2 mm R13	5
19746	Ø 8,3 mm	10	19788	Ø 13,5 mm R13	5
19747	Ø 8,4 mm	10	19789	Ø 14,0 mm R13	5
19748	Ø 8,5 mm	10	19790	Ø 14,5 mm R13	5
19749	Ø 8,6 mm	5	19791	Ø 15,0 mm R13	5
19750	Ø 8,7 mm	5	19792	Ø 15,5 mm R13	5
19751	Ø 8,8 mm	5	19793	Ø 16,0 mm R13	5
19752	Ø 8,9 mm	5	19794	Ø 16,5 mm R13	5
19753	Ø 9,0 mm	5	19795	Ø 17,0 mm R13	5
19754	Ø 9,1 mm	5	19796	Ø 17,5 mm R13	5
19755	Ø 9,2 mm	5	19797	Ø 18,0 mm R13	5
19756	Ø 9,3 mm	5	19798	Ø 18,5 mm R13	5
19757	Ø 9,4 mm	5	19799	Ø 19,0 mm R13	5
19758	Ø 9,5 mm	5	19800	Ø 19,5 mm R13	5
19759	Ø 9,6 mm	5	19801	Ø 20,0 mm R13	5

**FESTA****BOX - BURGIJA SPIRALNA HSS 4341 - KOMPLET**W 4%, Mo 3%
Cr 4%, V 1%**HSS****DIN
338****ALU****900
MPa**

Br.	Specifikacija	
19802		1
90192	bez burgija	1

Br.	obzah sady	Br.	obzah sady
19673	Ø 1,00 mm 20x	19728	Ø 6,50 mm 20x
19678	Ø 1,50 mm 20x	19733	Ø 7,00 mm 10x
19683	Ø 2,00 mm 20x	19738	Ø 7,50 mm 10x
19688	Ø 2,50 mm 20x	19743	Ø 8,00 mm 10x
19693	Ø 3,00 mm 30x	19748	Ø 8,50 mm 10x
19695	Ø 3,20 mm 30x	19753	Ø 9,00 mm 10x
19698	Ø 3,50 mm 30x	19758	Ø 9,50 mm 10x
19701	Ø 3,80 mm 30x	19763	Ø 10,00 mm 10x
19703	Ø 4,00 mm 30x	19768	Ø 10,50 mm 10x
19705	Ø 4,20 mm 30x	19772	Ø 11,00 mm 10x
19708	Ø 4,50 mm 30x	19776	Ø 11,50 mm 10x
19711	Ø 4,80 mm 30x	19781	Ø 12,00 mm 10x
19713	Ø 5,00 mm 20x	19783	Ø 12,50 mm 10x
19718	Ø 5,50 mm 20x	19786	Ø 13,00 mm 5x
19723	Ø 6,00 mm 20x		

FESTA**BURGIJA SPIRALNA HSS PRODUŽENE**W 4%, Mo 3%
Cr 4%, V 1% **HSS** **DIN 338**

MOQ

Br.	Specifikacija		Br.	Specifikacija	
20220	Ø 2,0 mm x 85 mm	10	20255	Ø 5,5 mm x 139 mm	10
20225	Ø 2,5 mm x 95 mm	10	20260	Ø 6,0 mm x 139 mm	10
20230	Ø 3,0 mm x 100 mm	10	20270	Ø 7,0 mm x 156 mm	10
20235	Ø 3,5 mm x 110 mm	10	20280	Ø 8,0 mm x 165 mm	10
20240	Ø 4,0 mm x 119 mm	10	20290	Ø 9,0 mm x 175 mm	10
20245	Ø 4,5 mm x 126 mm	10	20296	Ø 10,0 mm x 184 mm	10
20250	Ø 5,0 mm x 132 mm	10			

BURGIJA SPIRALNA HSS TIN

· Vrh do titana omogućava bolju upotrebu i vek trajanja

TiN **HSS** **DIN 338**

Br.	Specifikacija		Br.	Specifikacija		Br.	Specifikacija	
20400	Ø 1,0 mm	1	20411	Ø 4,8 mm	1	20422	Ø 9,5 mm	1
20401	Ø 1,5 mm	1	20412	Ø 5,0 mm	1	20423	Ø 10,0 mm	1
20402	Ø 2,0 mm	1	20413	Ø 5,5 mm	1	20424	Ø 10,2 mm	1
20403	Ø 2,5 mm	1	20414	Ø 6,0 mm	1	20425	Ø 10,5 mm	1
20404	Ø 3,0 mm	1	20415	Ø 6,5 mm	1	20426	Ø 11,0 mm	1
20405	Ø 3,2 mm	1	20416	Ø 6,8 mm	1	20427	Ø 11,5 mm	1
20406	Ø 3,5 mm	1	20417	Ø 7,0 mm	1	20428	Ø 12,0 mm	1
20407	Ø 3,8 mm	1	20418	Ø 7,5 mm	1	20429	Ø 12,5 mm	1
20408	Ø 4,0 mm	1	20419	Ø 8,0 mm	1	20430	Ø 13,0 mm	1
20409	Ø 4,2 mm	1	20420	Ø 8,5 mm	1			
20410	Ø 4,5 mm	1	20421	Ø 9,0 mm	1			

BURGIJA SPIRALNA HSS**HSS** **DIN 338**

Br.	Specifikacija		Br.	Specifikacija	
19841	Ø 4,1 mm 5 kom	10			
19842	Ø 4,2 mm 5 kom	10			
19845	Ø 4,5 mm 5 kom	10			
19885	Ø 8,5 mm 1 kom	10			
19895	Ø 9,5 mm 1 kom	10			



FESTA

HSS-G KOMPLET BURGIIJA ZA METAL

W 9%, Mo 3%
Cr 4%, V 1% **HSS** **DIN 338**

13x



Br. Specifikacija
20333 Ø 1,5 - 6,5 mm

1



FESTA

KOMPLET BURGIIJA ZA METAL

W 4%, Mo 3%
Cr 4%, V 1% **HSS** **DIN 338**

13x



Br. Specifikacija
20336 Ø 1,5 - 6,5 mm

1



FESTA

HSS-G KOMPLET BURGIIJA ZA METAL

W 9%, Mo 3%
Cr 4%, V 1% **HSS** **DIN 338**

19x



Br. Specifikacija
20334 Ø 1,0 - 10,0 mm

20



FESTA

KOMPLET BURGIIJA ZA METAL

W 4%, Mo 3%
Cr 4%, V 1% **HSS** **DIN 338**

19x



Br. Specifikacija
20337 Ø 1,0 - 10,0 mm

20



FESTA

HSS-G KOMPLET BURGIIJA ZA METAL

W 9%, Mo 3%
Cr 4%, V 1% **HSS** **DIN 338**

25x



Br. Specifikacija
20335 Ø 1,0 - 13,0 mm

5



FESTA

KOMPLET BURGIIJA ZA METAL

W 4%, Mo 3%
Cr 4%, V 1% **HSS** **DIN 338**

25x



Br. Specifikacija
20338 Ø 1,0 - 13,0 mm

10

FESTA

KOMPLET BURGIIJA

TiN



9x



Br.	Specifikacija	
20317	Ø 5-6-8 mm	20

FESTA

KOMPLET BURGIIJA SA ŠESTOUGAONIM DRŽAČEM

1/4" HSS



7x



Br.	Specifikacija	
20316	Ø 1,5-2-3-4-5-5,5-6 mm	20

KOMPLET BURGIIJA
ZA META

HSS DIN 338



19x



Br.	Specifikacija	
20305	Ø 1,0 - 13,0 mm	25

KOMPLET BURGIIJA
ZA META

HSS DIN 338



25x



Br.	Specifikacija	
20311	Ø 1,0 - 13,0 mm	10

KOMPLET BURGIIJA
ZA META

HSS DIN 338



13x



Br.	Specifikacija	
20300	Ø 1,5 - 6,5 mm	50

KOMPLET BURGIIJA
ZA META

HSS DIN 338



19x



Br.	Specifikacija	
20310	Ø 1 - 13 mm	10



KOMPLET BURGIJA ZA METAL

TiN **HSS** **DIN 338**

INOX **ALU**

19x



Br.	Specifikacija	
20320	Ø 1 - 10 x 0,5 mm	30



KOMPLET BURGIJA ZA METAL

HSS **DIN 338**

ALU

19x



Br.	Specifikacija	
20321	Ø 1 - 10 x 0,5 mm	5



KOMPLET BURGIJA

HSS **DIN 338**

ALU

19x

Br.	Specifikacija	
20315	Ø 1 - 10 mm	10



OŠTRAČ ZA BURGIJE

Br.	Specifikacija	
20380	za Ø 3,5 - 10 mm	20

FESTA

STEPENASTA BURGIJA TIN

TiN HSS



Br.	Specifikacija	
20489	Ø 4 - 12 mm 8 stepena	20
20490	Ø 4 - 20 mm 9 stepena	10
20491	Ø 5 - 35 mm 13 stepena	10
20492	Ø 7 - 40,5 mm 13 stepena	5

STEPENASTA BURGIJA HSS

HSS



Br.	Specifikacija	
20487	Ø 4 - 20 mm 9 stepena	10
20488	Ø 5 - 35 mm 13 stepena	10
20494	Ø 4 - 32 mm 15 stepena	10
20493	Ø 7 - 40,5 mm 13 stepena	1

FESTA

STEPENASTA BURGIJA TIN - KOMPLET

TiN HSS



3x



Br.	Specifikacija	
20495	Ø 4 - 12, 4 - 20, 4 - 32 mm	1

STEPENASTA BURGIJA HSS - KOMPLET

HSS



3x



Br.	Specifikacija	
20496	Ø 4 - 12, 4 - 20, 4 - 32 mm	1

**FESTA**

IZREZIVAČ RUPA, HSS BI-METAL

HSS



Br.	Specifikacija	
24419	Ø 19 mm	1
24420	Ø 20 mm	1
24422	Ø 22 mm	1
24425	Ø 25 mm	1
24429	Ø 29 mm	1
24432	Ø 32 mm	1
24435	Ø 35 mm	1
24437	Ø 37 mm	1
24444	Ø 44 mm	1
24451	Ø 51 mm	1
24457	Ø 57 mm	1
24464	Ø 64 mm	1
24476	Ø 76 mm	1
24483	Ø 83 mm	1



14 - 30 mm

FESTA

NOSAČ ZA IZREZIVAČ RUPA

Br.	Specifikacija	
24410	za rupa 14 - 30 mm	1



32 - 152 mm

FESTA

NOSAČ ZA IZREZIVAČ RUPA

Br.	Specifikacija	
24411	za rupa 32 - 152 mm	1

NEW**FESTA**

BURGIJA ZA NOSAČ ZA IZREZIVAČ RUPA

za 24410, 24411

Br.	Specifikacija	
24412		5

**FESTA**

KOMPLET IZREZIVAČA RUPA, HSS BI-METAL

HSS



9x

Br.	Specifikacija	
24750	Ø 19, 22, 29, 38, 44, 57 mm	10

**FESTA**

KOMPLET IZREZIVAČA RUPA, HSS BI-METAL

HSS



13x

Br.	Specifikacija	
24751	Ø 19, 22, 29, 35, 38, 44, 51, 57, 64 mm	10



FESTA

KOMPLET ZA VADJENJE

- Ø 4 mm Ø 11 mm
- Ø 4,5 mm Ø 15 mm
- Ø 6,5 mm Ø 19 mm
- Ø 7,5 mm Ø 24 mm

8x

Br.	Specifikacija	
20387		5



FESTA

KOMPLET ZA VADJENJE

- Ø 4 mm
- Ø 4,5 mm
- Ø 6 mm
- Ø 7,5 mm
- Ø 11 mm

5x

Br.	Specifikacija	
20386		10



KOMPLET ZA VADJENJE

- Ø 4 mm
- Ø 4,5 mm
- Ø 6 mm
- Ø 7,5 mm
- Ø 11 mm

5x

Br.	Specifikacija	
20385		10



DRŽAČ UREZNICA

Br.	Specifikacija	
20397	M3 - M8	10



FESTA

DRŽAČ NAREZNICA

DIN 225

Br.	Specifikacija	
20396	25 x 9 mm	10



FESTA

DRŽAČ UREZNICA

DIN 1814

Br.	Specifikacija	
20395	1 - 1/2; M3 - M12	10



FESTA

KOMPLET UREZNICA I NAREZNICA

32x

Br.	Specifikacija	
20391	M 3, 4, 5, 6, 8, 10, 12 mm	1



FESTA

KOMPLET UREZNICA

21x

Br.	Specifikacija	
20390	M 3, 4, 5, 6, 8, 10, 12 mm	1

FESTA**BURGIJA VIDIJUM**

· Burgija sa 2 oštrice

**DIN
8039**

Br.	Specifikacija	A mm	B mm	
20673	Ø 3 mm	60	30	100
20674	Ø 4 mm	75	40	100
20675	Ø 5 mm	85	50	100
20676	Ø 6 mm	100	60	100
20677	Ø 6 mm	200	160	50
20685	Ø 6 mm	300	260	50
20678	Ø 8 mm	120	75	50
20686	Ø 8 mm	200	155	50

Br.	Specifikacija	A mm	B mm	
20687	Ø 8 mm	300	255	25
20688	Ø 8 mm	400	340	25
20680	Ø 10 mm	120	70	50
20690	Ø 10 mm	200	150	50
20691	Ø 10 mm	300	250	25
20692	Ø 10 mm	400	340	25
20682	Ø 12 mm	150	100	50
20694	Ø 12 mm	300	250	25

Br.	Specifikacija	A mm	B mm	
20696	Ø 12 mm	400	340	25
20684	Ø 14 mm	150	90	25
	redukce Ø 10 mm			
20697	Ø 14 mm	300	240	5
	redukce Ø 10 mm			
20698	Ø 14 mm	400	340	15
	redukce Ø 10 mm			

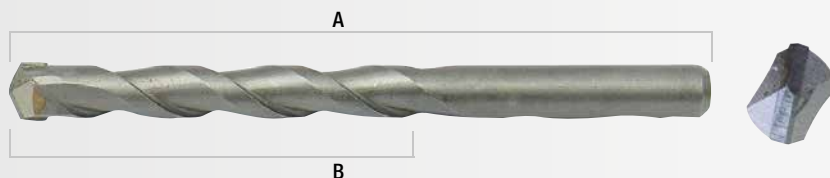
**FESTA****BURGIJA VIDIJUM SDS+**

· Burgija sa 2 oštrice

SDS+

Br.	Specifikacija	A mm	B mm	
20855	Ø 14 mm	160	75	25

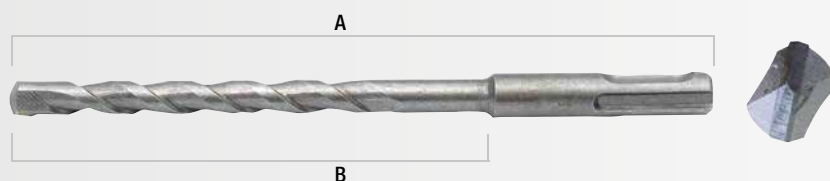
**FESTA****BURGIJA VIDIJUM SDS+**

· Burgija sa 4 oštrice-bolja upotreba i vek trajanja

SDS+

Br.	Specifikacija	A mm	B mm	
20748	Ø 6 mm	110	40	50
20749	Ø 6 mm	160	90	50
20750	Ø 6 mm	210	140	50
20751	Ø 6 mm	260	190	50
20861	Ø 6,5 mm	230	160	50
20862	Ø 6,5 mm	300	230	50
20752	Ø 8 mm	110	40	50
20753	Ø 8 mm	160	90	50
20754	Ø 8 mm	210	140	50
20755	Ø 8 mm	260	190	50
20825	Ø 8 mm	350	280	50
20756	Ø 10 mm	160	90	50
20757	Ø 10 mm	210	140	50
20758	Ø 10 mm	260	190	50
20759	Ø 10 mm	350	280	50
20760	Ø 10 mm	450	380	50
20761	Ø 10 mm	600	530	50
20762	Ø 10 mm	1000	930	50
20764	Ø 12 mm	160	80	50
20765	Ø 12 mm	210	130	50
20766	Ø 12 mm	260	180	50
20767	Ø 12 mm	350	270	50

Br.	Specifikacija	A mm	B mm	
20768	Ø 12 mm	460	380	50
20769	Ø 12 mm	600	520	25
20770	Ø 12 mm	1000	920	25
20771	Ø 14 mm	160	80	25
20772	Ø 14 mm	260	180	25
20773	Ø 14 mm	350	270	25
20774	Ø 14 mm	460	380	25
20775	Ø 14 mm	600	520	25
20776	Ø 14 mm	1000	920	30
20777	Ø 16 mm	160	80	25
20778	Ø 16 mm	210	130	25
20779	Ø 16 mm	260	180	25
20780	Ø 16 mm	350	270	25
20781	Ø 16 mm	460	380	25
20782	Ø 16 mm	600	520	30
20783	Ø 16 mm	1000	920	25
20784	Ø 18 mm	260	180	25
20785	Ø 18 mm	450	370	25
20786	Ø 18 mm	600	520	32
20787	Ø 18 mm	1000	920	20
20788	Ø 20 mm	450	370	20
20789	Ø 20 mm	600	520	20

Br.	Specifikacija	A mm	B mm	
20790	Ø 20 mm	800	720	25
20791	Ø 20 mm	1000	920	10
20792	Ø 22 mm	450	365	20
20793	Ø 22 mm	600	520	20
20794	Ø 22 mm	800	715	20
20795	Ø 22 mm	1000	920	10
20796	Ø 24 mm	450	365	10
20797	Ø 24 mm	600	520	20
20798	Ø 24 mm	800	715	10
20799	Ø 24 mm	1000	920	10
20870	Ø 26 mm	450	370	10
20871	Ø 26 mm	650	570	20
20872	Ø 26 mm	800	720	10
20873	Ø 26 mm	1000	920	10
20874	Ø 28 mm	450	365	10
20875	Ø 28 mm	600	565	20
20876	Ø 28 mm	800	715	10
20877	Ø 28 mm	1000	915	10
20878	Ø 30 mm	450	365	10
20879	Ø 30 mm	600	565	20
20880	Ø 30 mm	800	715	10
20881	Ø 30 mm	1000	915	10

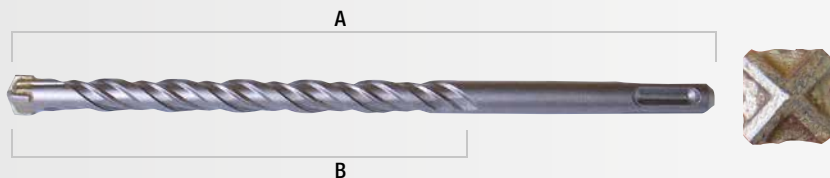

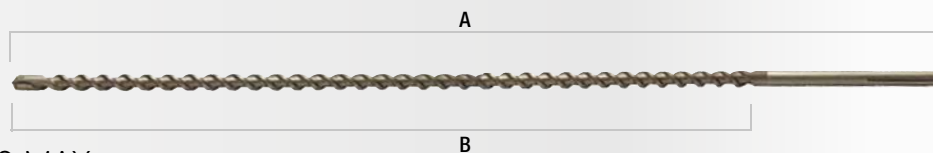

FESTA

BURGIJA VIDIJUM SDS MAX

• Burгија са 4 оштрице-боља употреба и век трајања

**SDS
MAX**



Br.	Specifikacija	A mm	B mm	
20508 NEW	Ø 16 mm	550	395	5
20510	Ø 18 mm	550	395	5
20520	Ø 18 mm	800	650	5
20511	Ø 20 mm	550	395	5
20521	Ø 20 mm	800	650	5

Br.	Specifikacija	A mm	B mm	
20512	Ø 22 mm	550	395	5
20522	Ø 22 mm	800	650	5
20513	Ø 24 mm	550	395	5
20523	Ø 24 mm	800	650	5
20514	Ø 28 mm	550	395	5

Br.	Specifikacija	A mm	B mm	
20524	Ø 28 mm	800	650	5
20515	Ø 30 mm	550	395	5
20525	Ø 30 mm	800	650	5
20516	Ø 40 mm	550	395	2
20526	Ø 40 mm	800	650	1



REKLAMNA POLICA

Br.	Specifikacija
20999	



1

BURGIJA KOMPLET SDS+

SDS+

5x



Br.	Specifikacija	
20890	Ø 5, 6, 8, 10, 12 mm 160 mm	25

BURGIJA KOMPLET SDS+

SDS+

6x



Br.	Specifikacija	
20891	Ø 5, 6, 8 mm 110 mm Ø 8, 10, 12 mm 160 mm	25

BURGIJA VIDIJUM KOMPLET

**DIN
8039**

6x



Br.	Specifikacija	
20895	Ø 5, 6, 8, 10, 12 mm	25

BURGIJA VIDIJUM KOMPLET



Br.	Specifikacija	
20805	5 kom Ø 4 - 10 mm	10
20820	8 kom Ø 3 - 10 mm	10

FESTA

SDS+ KOMPLET

- 2 x špic
- 3 x sekač
- 12 x burgija Ø 5-12 mm

SDS+



17x



Br. Specifikacija

20952



1

FESTA

SDS+ KOMPLET

- 1 x špic 250 mm
- 1 x sekač 22 x 250 mm
- 1 x sekač 20 x 250 mm

- Ø 5 x 110 mm
- Ø 6 x 110 mm
- Ø 8 x 160 mm
- Ø 10 x 160 mm
- Ø 12 x 160 mm
- Ø 14 x 210 mm
- Ø 16 x 210 mm
- Ø 18 x 310 mm
- Ø 20 x 450 mm

SDS+



12x



Br. Specifikacija

20950



5



FESTA

SDS+ KOMPLET

SDS+

4x



Br. Specifikacija

20954 250 mm

1

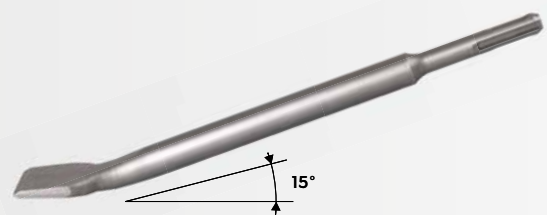

FESTA

SEKAČ ZA UDARNU BUŠILICU 15°

SDS+



Br. Specifikacija

20936 40 x 250 mm

5



FESTA

SEKAČ ZA UDARNU BUŠILICU

SDS
MAX



Br.	Specifikacija	
20940	25 x 280 mm	5
20941	40 x 280 mm	5
20942	75 x 280 mm	5
20943	25 x 400 mm	5
20944	40 x 400 mm	5
20945	25 x 600 mm	5
20946	50 x 600 mm	5



FESTA

SEKAČ ZA UDARNU BUŠILICU

SDS+



Br.	Specifikacija	
20948	20 x 250 mm	25
20990	20 x 400 mm	25
20949	40 x 250 mm	25
20991	40 x 400 mm	25



FESTA

ŠPIC ZA UDARNU BUŠILICU

SDS
MAX



Br.	Specifikacija	
20937	Ø 18 x 280 mm	5
20938	Ø 18 x 400 mm	5
20939	Ø 18 x 600 mm	2



FESTA

ŠPIC ZA UDARNU BUŠILICU

SDS+



Br.	Specifikacija	
20947	250 mm	25
20992	400 mm	25



FESTA

STEZNA GLAVA ZA BURGIIJE

SDS
MAX

Br.	Specifikacija	
24730	180 mm	1



FESTA

DLETO SDS+

SDS+



Br.	Specifikacija	
20956	22 x 250 mm	25



FESTA

STEZNA GLAVA ZA BURGIIJE

SDS+

Br.	Specifikacija	
24731	300 mm	1
24732		1



FESTA

ADAPTER SDS + NA BIT 1/4"



Br.	Specifikacija	
20743	75 mm	1



ADAPTER SDS MAX TO SDS +

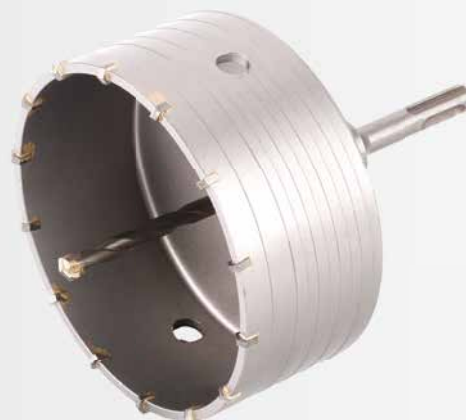

Br.	Specifikacija	
20744		1

**FESTA****SDS+ KRUNA ZA RUPE**

stezna glava za burgije 24730, 24731 a 24732

SDS+

Br.	Specifikacija	
24719	Ø 67 mm	1
24717	Ø 73 mm	1
24723	Ø 80 mm	1
24718	Ø 100 mm	1
24757	Ø 115 mm	1
24758	Ø 125 mm	1
24759	Ø 150 mm	1

**TESTERA KRUŽNA ZA PLOČICE**

Br.	Specifikacija	
24725	Ø 20-95mm	10

**TESTERA KRUŽNA ZA PLOČICE**

Br.	Specifikacija	
24726	Ø 20-95mm	1

**FESTA****KOMPLET KRUNA ZA IZREZIVANJE RUPA****8x**

Br.	Specifikacija	
24747	Ø 33, 53, 67, 73, 83 mm Nosач, burgija, nagibno sečivo	1

**FESTA****KOMPLET KRUNA ZA IZREZIVANJE RUPA****6x**

Br.	Specifikacija	
24745	Ø 33, 53, 67, 73 mm + nosач, burgija	1

FESTA

KRUNA ZA IZREZIVANJE RUPA



Br.	Specifikacija	
24735	Ø 33 mm	1
24736	Ø 43 mm	1
24737	Ø 53 mm	1
24738	Ø 67 mm	1
24739	Ø 73 mm	1
24740	Ø 83 mm	1
24741	Ø 103 mm	1



FESTA

KRUNA ZA IZREZIVANJE RUPA

3x



Br.	Specifikacija	
24746	Ø 103 mm + nosač, burgija	1



FESTA

NOSAČ



Br.	Specifikacija	
24748	Ø 33 - 83 mm	10
24743	Ø 33 - 103 mm	10

FESTA

BURGIJA



Br.	Specifikacija	
24749		50



NAGIBNO SEČIVO



Br.	Specifikacija	
22200	200 mm	20



NAGIBNO SEČIVO

· Za brušenje opeka



Br.	Specifikacija	
22201	200 mm dvoji asperity	20



FESTA

KRUNA ZA IZREZIVANJE RUPA - KARBID

· Za bušenje stakla i keramike
· Neophodno hlađenje



Br.	Specifikacija	
24770	Ø 4 mm	1
24771	Ø 6 mm	1
24772	Ø 8 mm	1
24773	Ø 10 mm	1
24774	Ø 12 mm	1



VODJICA ZA BUŠILICE I BURGIJE MERA

Br.	Specifikacija	
20379	Ø 4, 5, 6, 7, 8, 10, 12 mm	10



**FESTA**

DIJAMANTNA KRUNA ZA IZREZIVANJE RUPA

M14

- Keramičke pločice
- Mermer
- Granit



- Upotreba bez vodenog hlađenja



Br.	Specifikacija	učyt	
24760	Ø 6 mm	M14	1
24761	Ø 8 mm	M14	1
24762	Ø 10 mm	M14	1
24763	Ø 12 mm	M14	1
24764	Ø 14 mm	M14	1
24670 NEW	Ø 16 mm	M14	1
24671 NEW	Ø 18 mm	M14	1
24790	Ø 20 mm	M14	1
24672 NEW	Ø 22 mm	M14	1
24673 NEW	Ø 25 mm	M14	1
24765	Ø 28 mm	M14	1
24674 NEW	Ø 30 mm	M14	1

Br.	Specifikacija	učyt	
24675 NEW	Ø 32 mm	M14	1
24766	Ø 35 mm	M14	1
24776 NEW	Ø 40 mm	M14	1
24767	Ø 45 mm	M14	1
24791	Ø 50 mm	M14	1
24768	Ø 53 mm	M14	1
24792	Ø 60 mm	M14	1
24793	Ø 65 mm	M14	1
24769	Ø 68 mm	M14	1
24794	Ø 75 mm	M14	1
24796	Ø 83 mm	M14	1
24676 NEW	Ø 110 mm	M14	1

**FESTA**

DIJAMANTNA KRUNA ZA IZREZIVANJE RUPA



- Keramičke pločice
- Mermer
- Granit



Br.	Specifikacija	
24700	Ø 6 mm	1
24701	Ø 8 mm	1
24702	Ø 10 mm	1
24703	Ø 12 mm	1
24704	Ø 14 mm	1
24705	Ø 20 mm	1

NEW**FESTA**

DIJAMANTNA KRUNA ZA IZREZIVANJE RUPA

- Ø 8 mm
- Ø 10 mm
- Ø 14 mm
- Ø 22 mm
- Ø 32 mm
- Ø 40 mm
- Ø 68 mm

7x M14

- Keramičke pločice
- Mermer
- Granit



- Upotreba bez vodenog hlađenja



Br.	Specifikacija	
24650		1

**FESTA**

DIJAMANTNA KRUNA ZA IZREZIVANJE RUPA

6x

- Keramičke pločice
- Mermer
- Granit



Br.	Specifikacija	
24798	Ø 6, 8, 10, 12, 14, 20 mm	1

NEW

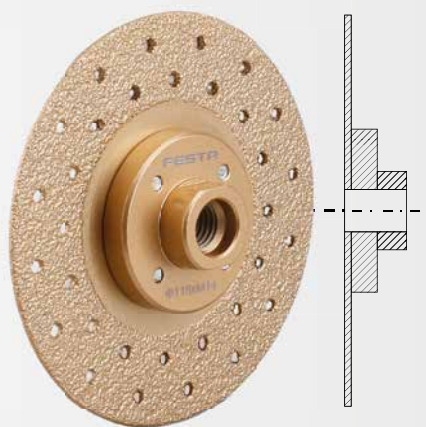

FESTA
DIJAMANTSKA
REZNA, BRUSNA
PLOČA

M14

- Keramičke pločice
- Mermer
- Granit

- Upotreba bez vodenog hlađenja

Br.	Specifikacija	
24655	Ø 115 mm M14	1

NEW

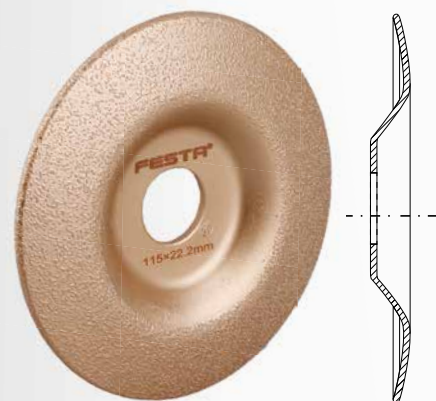

FESTA
DIJAMANTSKA
BRUSNA PLOČA

- Keramičke pločice
- Mermer
- Granit

- Upotreba bez vodenog hlađenja

Br.	Specifikacija	
24658	Ø 115 mm Ø 22,2 mm	1

NEW

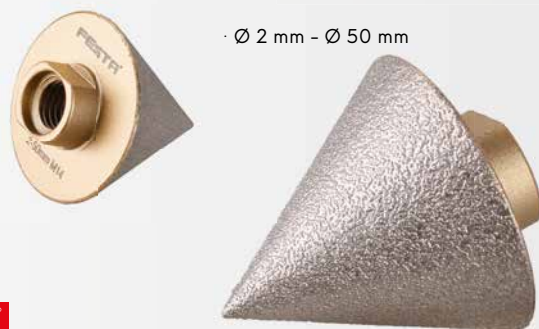

FESTA
DIJAMANTNA KRUNA BRUSNA

M14

- Keramičke pločice
- Mermer
- Granit

- Upotreba bez vodenog hlađenja

Br.	Specifikacija	
24778	Ø 2 - 50 mm	1

NEW



FESTA
DIJAMANTNA KRUNA BRUSNA

M14

- Keramičke pločice
- Mermer
- Granit

- Upotreba bez vodenog hlađenja

Br.	Specifikacija	
24779	Ø 20 - 48 mm	1



FESTA
DIJAMANTSKA KRUNA ZA
BRUŠENJE

M14

- Keramičke pločice
- Mermer
- Granit

- Upotreba bez vodenog hlađenja

Br.	Specifikacija	
24795	Ø 20 x 50 mm	1

FESTA
BURGIJE ZA STAKLO I
KERAMIKU

TiN

1/4"

- Keramičke pločice
- Mermer

Br.	Specifikacija	
24780	Ø 4 mm	40
24781	Ø 5 mm	40
24782	Ø 6 mm	40
24783	Ø 8 mm	40
24784	Ø 10 mm	40
24785	Ø 12 mm	40
24786	Ø 14 mm	1
24787	Ø 16 mm	1
24788	Ø 18 mm	1
24789	Ø 20 mm	1





FESTO

KOMPLET SEKAČA I PROBIJAČA

CrV

12x

-  2, 6, 8 mm
-  10, 12, 16 mm
-  Ø 1,5-3-4-5-6-8 mm



Br.	Specifikacija
19487	



4

FESTO

KOMPLET SEKAČA I PROBIJAČA

CrV

6x

-  2 x 140, 8 x 115 mm
-  12 x 152, 10 x 142 mm
-  Ø 3 x 152, 6 x 152 mm



Br.	Specifikacija
19486	

10



FESTO

SEKAČ

CrV

Br.	Specifikacija
19429	200 mm



1



FESTO

KOMPLET SEKAČA

CrV

3x

-  10, 12, 16 mm



Br.	Specifikacija
19485	

10



FESTO

SEKAČ

CrV

Br.	Specifikacija		
19410	200 mm	20 mm	10
19411	250 mm	25 mm	10
19412	300 mm	25 mm	10
19418	400 mm	25 mm	5
19419	500 mm	25 mm	5



SEKAČ

CrV

Br.	Specifikacija		
19436	200 mm	20 mm	15



FESTA

KOMPLET PROBIJAČA

CrV 6x

Br.	Specifikacija	
19483	Ø 3, 4, 5, 6, 7, 8 mm	5



FESTA

KOMPLET PROBIJAČA

CrV 6x

Br.	Specifikacija	
19482	Ø 3, 4, 5, 6, 8 mm	5



FESTA

PROBIJAČ

CrV

Br.	Specifikacija	
19472	Ø 4 mm 150 mm	1
19473	Ø 5 mm 150 mm	1
19474	Ø 6 mm 150 mm	1



FESTA

KOMPLET PROBIJAČA

CrV 3x

Br.	Specifikacija	
19480	Ø 0.8, 1.5, 2.5 mm	10



FESTA

TAČKASTI PROBIJAČ

CrV

Br.	Specifikacija	
19477	Ø 2,5 mm	20



FESTA

TAČKASTI PROBIJAČ

CrV 3x

Br.	Specifikacija	
19481	Ø 0.8, 1.5, 2.5 mm	10



FESTA

TAČKASTI PROBIJAČ

CrV

Br.	Specifikacija	
19478	Ø 2,5 mm	12



REZAČ STAKLA



Br.	Specifikacija	
20350	130 mm	12

**FESTA****BURGIJA ZA DRVO**

Br.	Specifikacija		Br.	Specifikacija	
20980	Ø 6 x 230 mm	1	20984	Ø 16 x 230 mm	1
20957	Ø 6 x 300 mm	1	20899	Ø 16 x 300 mm	1
20981	Ø 8 x 230 mm	1	20917	Ø 16 x 450 mm	1
20958	Ø 8 x 300 mm	1	20922	Ø 16 x 600 mm	1
20982	Ø 10 x 230 mm	1	20918	Ø 18 x 450 mm	1
20896	Ø 10 x 300 mm	1	20923	Ø 18 x 600 mm	1
20913	Ø 10 x 450 mm	1	20919	Ø 20 x 450 mm	1
20983	Ø 12 x 230 mm	1	20924	Ø 20 x 600 mm	1
20897	Ø 12 x 300 mm	1	20724	Ø 22 x 450 mm	1
20915	Ø 12 x 450 mm	1	20725	Ø 24 x 450 mm	1
20920	Ø 12 x 600 mm	1	20726	Ø 26 x 450 mm	1
20898	Ø 14 x 300 mm	1	20727	Ø 28 x 450 mm	1
20916	Ø 14 x 450 mm	1	20728	Ø 30 x 450 mm	1
20921	Ø 14 x 600 mm	1			

**FESTA****BURGIJA ZA DRVO****5x**

Br.	Specifikacija	
20911	Ø 8, 10, 12, 14, 16 x 460 mm	10

**FESTA****BURGIJA ZA DRVO****6x**

Br.	Specifikacija	
20912	Ø 6, 8, 10, 12, 16, 20 x 230 mm	10

**BURGIJA ZA DRVO**

Br.	Specifikacija	
20729	Ø 6 x 400 mm	1
20731	Ø 8 x 400 mm	1
20736	Ø 8 x 600 mm	1
20730	Ø 10 x 400 mm	1
20737	Ø 10 x 600 mm	1

Br.	Specifikacija	
20732	Ø 12 x 400 mm	1
20738	Ø 12 x 600 mm	1
20733	Ø 14 x 400 mm	1
20739	Ø 14 x 600 mm	1

Br.	Specifikacija	
20734	Ø 16 x 400 mm	1
20740	Ø 16 x 600 mm	1
20735	Ø 18 x 400 mm	1
20741	Ø 18 x 600 mm	1

**BURGIJA ZA DRVO**

Br.	Specifikacija	
21440	Ø 4 x 75 mm	1
21441	Ø 5 x 85 mm	1
21442	Ø 6 x 90 mm	1
21443	Ø 7 x 105 mm	1
21444	Ø 8 x 115 mm	1
21445	Ø 9 x 120 mm	1
21446	Ø 10 x 120 mm	1

BURGIJA ZA DRVO KOMPLET

Br.	Specifikacija	
20910	8 kom Ø 3, 4, 5, 6, 7, 8, 9, 10 mm	10
20905	5 kom Ø 4, 5, 6, 8, 10 mm	10



FREZA TITAN HSS

HSS TiN



Br.	Specifikacija	
20460	Ø 6 mm	50

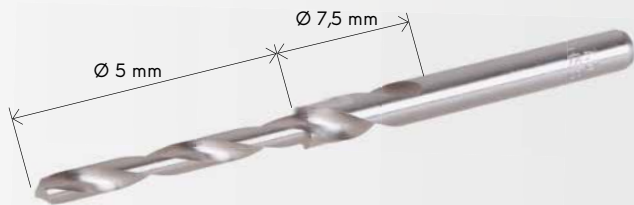

FESTA

DVOSTEPENA BURGIIJA

HSS



Br.	Specifikacija	
20210	Ø 7,5, 5 mm	1

FREZE KOMPLET

HSS TiN



6x



Br.	Specifikacija	
20450	Ø 3, 4, 5, 6, 6.5, 8 mm	20



BURGIIJA ZA DRVO KOMPLET



6x

Br.	Specifikacija	
20901	Ø 10, 12, 16, 18, 20, 25 mm	20

FREZER ZA DRVO



5x

Br.	Specifikacija	
21530	Ø 15, 20, 25, 30, 35 mm Ø 8 mm	20



FREZER ZA DRVO



5x

Br.	Specifikacija	
21450	Ø 8 mm	1



FREZER ZA DRVO



12x

Br.	Specifikacija	
21451	Ø 8 mm	1



FREZER ZA DRVO



24x

Br.	Specifikacija	
21452	Ø 8 mm	1



FREZER ZA DRVO



35x



1

Br.	Specifikacija
21453	Ø 8 mm



FREZER ZA DRVO



59x



1

Br.	Specifikacija
21454	Ø 8 mm



TURPIJICE ROTACIONE

6 mm 12 mm

5x



25

Br.	Specifikacija
21541	



BRUSNI KAMEN

5x



12

Br.	Specifikacija
21540	Ø 3 mm, 6 mm



KOMPLET ROTACIONIH BRUSEVA

100x



5

Br.	Specifikacija
24755	



KOMPLET ROTACIONIH BRUSEVA

150x



10

Br.	Specifikacija
24756	

NEW



· Ø 19 - 127 mm

FESTA

KRUNA ZA RUPE - PODESIVO



Br.	Specifikacija		
24415	Ø 19 - 127 mm	maksimalna dubina 29 mm	6

FESTA

TESTERA KRUŽNA KOMPLET

- Ø 19 mm
- Ø 22 mm
- Ø 25,5 mm
- Ø 36 mm
- Ø 44 mm
- Ø 51 mm
- Ø 60 mm
- Ø 67 mm
- Ø 76 mm
- Ø 82 mm
- Inbus
- 2x glava



Br.	Specifikacija		
24712	6 tpi		20

FESTA

TESTERA KRUŽNA KOMPLET

- Ø 64 mm
- Ø 73 mm
- Ø 89 mm
- Ø 102 mm
- Ø 127 mm
- Glava
- Inbus

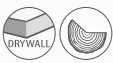

Br.	Specifikacija		
24706	6 tpi		20

**FESTA****TESTERA KRUŽNA KOMPLET**

Br.	Specifikacija	
24715	1' Ø 67 mm 6 tpi	5
24713	1' Ø 73 mm 6 tpi	5
24714	1' Ø 102 mm 6 tpi	5
24720	1' Ø 152 mm 6 tpi	5

**TESTERA KRUŽNA**

Br.	Specifikacija	
24721	1' Ø 26, 32, 38, 45, 50, 56, 63 mm	10
24722	2' Ø 26, 32, 38, 45, 50, 56, 63 mm	10

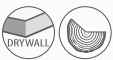
**PODESIVO SEČIVO ZA RUPE**

Br.	Specifikacija	
24716	Ø 30 - 120 mm	5

**RUČNA BURGIJA SET****HOBBY****4x**

Br.	Specifikacija	
20381	Ø 2, 3, 4, 5 mm	20

**ADAPTER SDS MAX / SDS+**

Br.	Specifikacija	
20744		1

ADAPTER SDS+ / 1/2" UNF

Br.	Specifikacija	
20745		1



FESTA

GLAVA ZA BUŠILICU

1/2"



Br.	Specifikacija	
20960	1-13 mm + 2 ključe, 1/2 - 20 UNF	3
20966	Rezervno ključ	25



FESTA

GLAVA ZA BUŠILICU QUICK GRIP

1/2"



Br.	Specifikacija	
20965	1,5 - 13 mm 1/2' - 20 UNF	1



GLAVA ZA BUŠILICU QUICK

1/2"



Br.	Specifikacija	
20961	1,5 - 13 mm 1/2' - 20 UNF	1



ADAPTER ZA BUŠENJE 90°

Br.	Specifikacija	
20365	Ø 1,0 - 10 mm	10



GLAVA ZA BUŠILICU QUICK GRIP

1/4"



Br.	Specifikacija	
20963	Ø 1 - 6 mm	10



UDARNICE BROJEVI

Br.	Specifikacija	
20972	6 mm	5
20973	8 mm	5



ZUMBE

13x



Br.	Specifikacija	
24695	Ø 5, 6, 8, 10, 11, 13, 16, 19, 22, 25, 28, 32, 35 mm	5



PROBOJAC SET

24690 - Ø 2,5 mm	24691 - Ø 2mm
Ø 3 mm	Ø 2,5 mm
Ø 4 mm	Ø 3,2 mm
Ø 5 mm	Ø 4 mm
Ø 6 mm	Ø 4,8 mm
Ø 7 mm	Ø 5 mm
Ø 8 mm	Ø 6,4 mm
Ø 9 mm	Ø 8 mm
Ø 10 mm	Ø 9,5 mm
	Ø 11,1 mm
	Ø 12,7 mm
	Ø 14 mm
	Ø 15,8 mm
	Ø 19 mm
	Ø 22 mm

Br.	Specifikacija	
24690	9 kom Ø 2,5 - 10 mm	10
24691	15 kom Ø 2 - 22 mm	5



UDARNICE SLOVA

Br.	Specifikacija	
20970	6 mm	5
20971	8 mm	5

FESTA®

ČETKE



20mm

FESTA®

ČETKA ČEL. POLULONČASTA

· Mesingani premaz

M14

Br.	Specifikacija	Žice	
21900	Ø 100 mm M14	s 0,3	60
21902	Ø 125 mm M14	s 0,3	42



10mm

FESTA®

ČETKA ČEL. POLULONČASTA

· Mesingani premaz

M14

Br.	Specifikacija	Žice	
22001	Ø 100 mm M14	s 0,3	60
21901	Ø 125 mm M14	s 0,3	42

**FESTA®**

ČETKA ČEL. POLULONČASTA

· Mesing

M14

Br.	Specifikacija	Žice	
21920	Ø 100 mm M14	s 0,3	60

**FESTA®**

ČETKA ČEL. LONČASTA

· Mesingani premaz

M14

Br.	Specifikacija	Žice	
21903	Ø 65 mm M14	s 0,3	60
22002	Ø 75 mm M14	s 0,3	80
21904	Ø 85 mm M14	s 0,3	60
22003	Ø 100 mm M14	s 0,3	36
21905	Ø 125 mm M14	s 0,3	24
21906	Ø 150 mm M14	s 0,3	12

**FESTA®**

ČETKA ČEL. LONČASTA

· Mesing

M14

Br.	Specifikacija	Žice	
21925	Ø 75 mm M14	0,3 mm	80
21926	Ø 100 mm M14	0,3 mm	36

**FESTA®**

ČETKA ČEL. PLJOSNATA

· Mesingani premaz

· Redukcijski prstenovi

M14

Br.	Specifikacija	Žice	
22007	Ø 100 mm Ø 20 mm	s 0,3	60
22008	Ø 125 mm Ø 20 mm	s 0,3	42
22009	Ø 150 mm Ø 32,2 mm	s 0,3	32
22010	Ø 175 mm Ø 32,2 mm	s 0,3	20
22011	Ø 200 mm Ø 32,2 mm	s 0,3	20



FESTA

ČETKA ČEL. ZA BRUSILICU

· Otvrdnuto

M14



Br.	Specifikacija	Žice	
22004	Ø 65 mm M14	s 0,3	60
22005	Ø 75 mm M14	s 0,3	24
22006	Ø 100 mm M14	s 0,3	24
21907	Ø 125 mm M14	s 0,3	24
21908	Ø 150 mm M14	s 0,3	12



FESTA

ČETKA ČEL. ZA BRUSILICU

· Otvrdnuto

INOX M14



Br.	Specifikacija	Žice	
22037	Ø 65 mm M14	s 0,5	60
22038	Ø 80 mm M14	s 0,5	24



FESTA

ČETKA ČEL. PLJOSNATA

· Otvrdnuto

M14



Br.	Specifikacija	Žice	počet copū	
21911	Ø 100 mm M14	s 0,5	30	60
21912	Ø 115 mm M14	s 0,5	32	42
21913	Ø 125 mm M14	s 0,5	36	42
21914	Ø 150 mm M14	s 0,5	40	32



FESTA

ČETKA ČEL. PLJOSNATA

· Otvrdnuto

M14



Br.	Specifikacija	Žice	
22012	Ø 100 mm M14	s 0,5	60
22013	Ø 115 mm M14	s 0,5	42
22014	Ø 125 mm M14	s 0,5	42
22015	Ø 150 mm M14	s 0,5	32
22016	Ø 178 mm M14	s 0,5	20



FESTA

ČETKA ČEL. PLJOSNATA

· Otvrdnuto

INOX M14



Br.	Specifikacija	Žice	
22039	Ø 100 mm M14	s 0,5	60
22040	Ø 125 mm M14	s 0,5	42



FESTA

ČETKA ČEL. POLULONČASTA

· Otvrdnuto

M14



Br.	Specifikacija	Žice	
22017	Ø 100 mm M14	s 0,5	60
21909	Ø 115 mm M14	s 0,5	42
21910	Ø 125 mm M14	s 0,5	42



FESTA

ČETKA ČEL. PLJOSNATA UPREDENA

· Otvrdnuto

M14



Br.	Specifikacija	Žice	
22023	Ø 75 mm	s 0,5	10



FESTA

ČETKA ČEL. LONČASTA UPREDENA

· Otvrdnuto

M14



Br.	Specifikacija	Žice	
22024	Ø 75 mm	s 0,5	12



FESTA

ČETKA ČEL. POLULONČASTA UPREDENA

· Otvrdnuto

M14



Br.	Specifikacija	Žice	
22025	Ø 75 mm	s 0,5	12

Ø 6 mm



Ø 6 mm



Ø 6 mm

**FESTA**

ČETKA ČEL. PLJOSNATA

Mesingani premaz



Br.	Specifikacija	Žice	
22026	Ø 50 mm	s 0,3	15
22027	Ø 63 mm	s 0,3	15
22028	Ø 75 mm	s 0,3	10
22029	Ø 100 mm	s 0,3	15

FESTA

ČETKA ČEL. LONČASTA

Mesingani premaz



Br.	Specifikacija	Žice	
22030	Ø 65 mm	s 0,3	12
22031	Ø 75 mm	s 0,3	12

FESTA

ČETKA ČEL. UPREDENA

Otvrdnuto



Br.	Specifikacija	Žice	
22021	Ø 19 mm	s 0,5	30
22022	Ø 22 mm	s 0,5	25



Ø 6 mm



Ø 6 mm

**FESTA**

ČETKA ČEL.



Br.	Specifikacija	Žice	
22058	Ø 12 mm	s 0,3	25
22059	Ø 25 mm	s 0,3	25

FESTA

ČETKA ČEL.

Mesingani premaz



Br.	Specifikacija	Žice	
22018	Ø 12 mm	s 0,3	15
22019	Ø 17 mm	s 0,3	15
22020	Ø 25 mm	s 0,3	25

FESTA

ČETKA OKRUGLA ZA POLIRANJE

M14 NYLON



Br.	Specifikacija	Žice	
21930	Ø 125 mm	M14 1,2 mm	10
21931	Ø 150 mm	M14 1,2 mm	15



Ø 6 mm

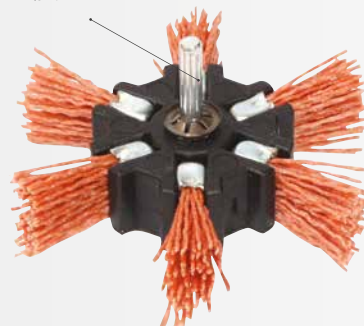

Ø 6 mm

**FESTA**

ČETKA LONČASTA ZA POLIRANJE

M14 NYLON



Br.	Specifikacija	Žice	
21940	Ø 75 mm	M14 1,2 mm	1
21941	Ø 100 mm	M14 1,2 mm	1

FESTA

ČETKA OKRUGLA ZA POLIRANJE

NYLON



Br.	Specifikacija	Žice	
21935	Ø 50 mm	1,2 mm	15
21936	Ø 75 mm	1,2 mm	10
21937	Ø 100 mm	1,2 mm	15

FESTA

ČETKA OKRUGLA ZA POLIRANJE

NYLON



Br.	Specifikacija	Žice	
22032	Ø 100 mm	1,2 mm	12



ŽIČANA ČETKA

Br.	Specifikacija	Žice	
22158	200 mm	Čelik	36
22159	200 mm	brass	36



ČETKA ČEL. PVC DRŠKA

Br.	Specifikacija	Žice	
22035	270 mm	Čelik	24
22036	270 mm	Rost-frei	24



ČETKA ČEL. DRVENA DRŠKA

Br.	Specifikacija	reda	
22033	300 mm	4 reda	12
22034	300 mm	5 reda	12



ČETKA DRVENA DRŠKA

· Mesingani premaz

Br.	reda	
22078	3 reda	20



ČETKA DRVENA DRŠKA

· Mesingani premaz

Br.	Specifikacija	reda	
22079	300 mm	4 reda	6



FESTA

ČETKA ČEL.

Br.	Specifikacija	reda	
22080	270 mm	5 reda	12



FESTA

ČETKA MESING

Br.	Specifikacija	reda	
22082	300 mm	5 reda	12



ČETKE KOMPLET, PLASTIČNA RUČKA

3x



Br.	reda	
22081	3 reda	12



FESTA

ČETKE KOMPLET, PLASTIČNA RUČKA

· Nylon, rost-frei, mesing

3x



Br.	Specifikacija	
22086	180 mm	12

**FESTA**

DIJAMANTSKI DISK ZA POLIRANJE Ø 100 MM, NA ČIČAK

- Keramičke pločice
- staklo
- Mermer
- Granit



Br.	asperity	
22701	50	1
22702	100	1
22703	200	1
22704	400	1
22705	800	1
22706	1500	1
22707	3000	1

**FESTA**

GUMENI DISK ZA BUŠILICU, NA ČIČAK

- M14 | Ø 8 mm
- EVA 10 mm

M14

Br.	Specifikacija	
22062	Ø 115 mm	25
22063	Ø 125 mm	25
22064	Ø 150 mm	10

**FESTA**

GUMENI DISK ZA BRUSILICU ZA FIBER DISK

NORTON MADE IN EU
SAINT-GOBAIN

M14

Br.	Specifikacija	
22073	Ø 125 mm, M14	1
22074	Ø 150 mm, M14	1

**FESTA**

GUMENI DISK ZA BRUSILICU

- Za ugaonu brusilicu

M14

Br.	Specifikacija	
22043	Ø 100 mm Na čičak	1

**M14**

Br.	Specifikacija	
22044	Ø 125 mm M14 Na čičak	15
22060	Ø 150 mm M14 Na čičak	6

**ADAPTER****M14**

Br.	Specifikacija	
22087		1



GUMENI DISK ZA BUŠILICU



Br.	Specifikacija	stopka shank	
22061	Ø 125 mm Na čičak	Ø 8 mm	6

GUMENI DISK ZA BUŠILICU



Br.	Specifikacija	
22041	Ø 125 mm Učvršćivanje vijkom	11
22042	Ø 125 mm Na čičak	11



POLIR JASTUČE



Br.	Specifikacija	Specifikacija	
22065	Ø 125 mm	Na čičak	20
22066	Ø 150 mm	Na čičak	20



POLIR JASTUČE- VUNENI



Br.	Specifikacija	
22068	Ø 125 mm	20
22069	Ø 150 mm	20

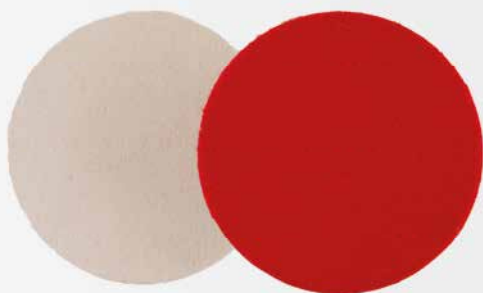

DISK ZA POLIRANJE

Br.	Specifikacija	
22070	Ø 115 mm	20
22071	Ø 125 mm	Na čičak 20
22072	Ø 150 mm	20



ČETKA NAJLON, BRUSNI



Br.	Specifikacija	
22091	Ø 50 mm P240	1
22092	Ø 75 mm P240	1
22093	Ø 100 mm P240	1



ČETKA NAJLON



Br.	Specifikacija	
21798	Ø 125 mm Ø 22,2 mm	1



ČETKA NAJLON



Br.	Specifikacija	
22088	Ø 65 mm	9
22090	Ø 100 mm	5



ČETKA NAJLON ZA POLIRANJE



Br.	Specifikacija	
22083	Ø 115 mm Ø 22,2 mm	10
22084	Ø 125 mm Ø 22,2 mm	10
22085	Ø 150 mm Ø 22,2 mm	10



ČETKA NAJLON



Br.	Specifikacija	
22095	Ø 178 mm	1

**FESTA**

FIBER DISK - Ø 125 MM

3x



Br.	asperity	
22160	P40	1
22161	P60	1
22162	P80	1
22163	P100	1
22164	P120	1

**FESTA**

FIBER DISK - Ø 150 MM

3x



Br.	asperity	
22166	P60	1
22167	P80	1
22168	P100	1

**FESTA**

BRUSNI PAPIR Ø 125 MM, NA ČIČAK

3x



Br.	asperity	
22045	P40	1
22046	P60	1
22047	P80	1
22048	P100	1
22049	P120	1
22050	P150	1
22051	P180	1
22052	P220	1

**FESTA**

BRUSNI PAPIR Ø 150 MM, NA ČIČAK

3x

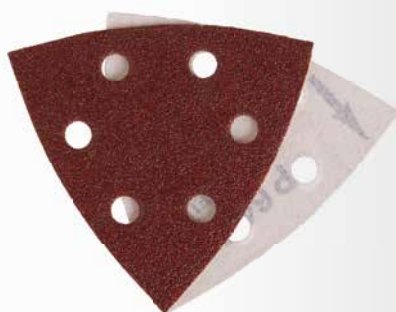

Br.	asperity	
22053	P40	1
22054	P60	1
22055	P80	1
22056	P100	1
22057	P120	1

**FESTA**

BRUSNI PAPIR NA 94 X 94 X 94 MM

5x



Br.	asperity	
21831	P60	1
21832	P80	1
21834	P120	1



BRUSNI PAPIR NA ČIČAK 125 MM

3x

Br.	asperity	
22096	P40	20
22097	P60	20
22098	P80	20
22099	P120	20

**FESTA**

BRUSNA TRAKA 75 X 533 MM

3x



Br.	asperity	
21810	P40	20
21811	P60	20
21812	P80	20
21813	P100	20
21814	P120	20



BRUSNI PAPIR 93 X 230 MM NA ČIČAK

5x



Br.	asperity	number of holes	
21740	P40	8	20
21741	P60	8	20
21742	P80	8	20
21743	P100	8	20
21744	P120	8	20

BRUSNI PAPIR 115 X 280 MM NA ČIČAK

5x



Br.	asperity	number of holes	
21750	P40	10	20
21751	P60	10	20
21752	P80	10	20
21753	P100	10	20
21754	P120	10	20

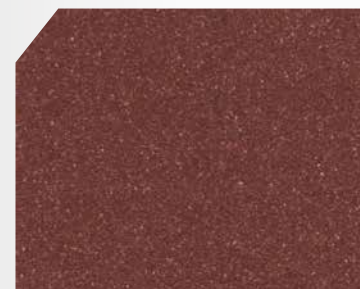
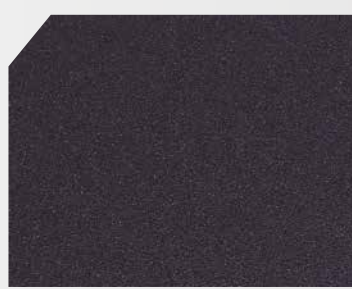
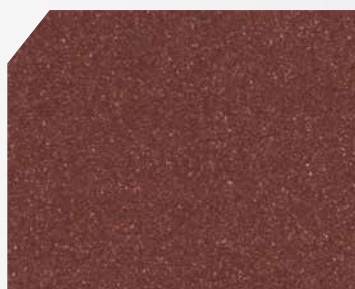

BRUSNI PAPIR NA PLATNU 30 X 280 MM

10x

Br.	asperity	
21732	P40	1
21734	P60	1
21735	P80	1
21736	P100	1
21737	P120	1

10x

Br.	asperity	
21701	P60	1
21702	P80	1
21703	P100	1
21704	P120	1
21705	P150	1
21706	P180	1
21709	P240	1

BRUSNI PAPIR 230 X 280 MM

10x

Br.	asperity	
21715	P40	1
21716	P60	1
21717	P80	1
21718	P100	1
21719	P120	1
21720	P150	1
21721	P180	1
21724	P240	1



FESTA

DRŽAČ BRUSNOG PAPIRA

Quick grip

Br.	Specifikacija	
22067	170 x 70 mm	10

DRŽAČ BRUSNOG PAPIRA



Br.	Specifikacija	
22075	210 x 105 mm	100
22076	160 x 85 mm	100

DRŽAČ BRUSNOG PAPIRA

Br.	Specifikacija	
22077	125 x 68 mm	10

**FESTA****DIJAMANTSKI ABRAZIVNI SUNDJER**

- 90 x 55 x 25 mm
- Keramičke pločice
- staklo
- Mermer
- Granit



Br.	asperity	
22115	P60	10
22116	P120	10
22117	P200	10

BRUSNE LAMELNE LEPEZE

Br.	asperity	Specifikacija	
21850	P40		1
21851	P60		1
21852	P80	20 x 20, Ø 6 mm	1
21853	P100		1
21854	P120		1
21855	P40		1
21856	P60		1
21857	P80	30x30, Ø 6mm	1
21858	P100		1
21859	P120		1
21860	P40		1
21861	P60		1
21862	P80	60x30, Ø 6mm	1
21863	P100		1
21864	P120		1

**FESTA****BRUSNI SUNDJER 100 X 70 X 28 MM - ZAKOŠENY**

Br.	asperity	
22106	P 60	10
22107	P 80	10
22108	P 100	10
22109	P 120	10

**FESTA****BRUSNI SUNDJER 100 X 70 X 25 MM**

Br.	asperity	
22100	P60	20
22101	P80	20
22102	P100	20
22103	P120	20
22104	P180	20
22105	P220	20

**FESTA****BRUSNI SUNDJER 120 X 95 X 10 MM**

Br.	asperity	
22110	P80	20
22111	P120	20
22112	P180	20
22113	P220	20

GIPS KARTON ALATI



RENDE ZA GIP. PLOČE

Br.	Specifikacija	
22120	250 x 40 mm	10



RENDE ZA GIP. PLOČE

Br.	Specifikacija	
22121	250 x 40 mm	10
22122	140 x 40 mm	6



RENDE ZA GIP. PLOČE

Br.	Specifikacija	
22126	155 x 40 mm	1



RENDE ZA GIP. PLOČE

Br.	Specifikacija	
22125	Ø 250 x 40 mm	6



RENDE ZA GIP. PLOČE

Br.	Specifikacija	
22124	Ø 250 x 16 mm	10



RENDE ZA GIP. PLOČE

Br.	Specifikacija	
22123	60 x 40 mm	6



FESTA
TESTERA ZA GIPSANE PLOČE

Br.	Specifikacija	
24159	150 mm	12

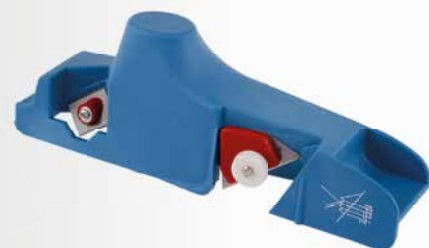

RENDE ZA GIP. PLOČE

Br.	Specifikacija	
34315		10
34316	Rezervno břit	1



BOSNEK ZA GIP. PLOČE

Br.	Specifikacija	
24190	270 mm	10

RENDE REZERVA

Br.	Specifikacija	
22130	250 x 40 mm	20
22129	155 x 40 mm	20
22132	140 x 40 mm	20
22133	60 x 40 mm	20
22134	Ø 16 x 250 mm	20





TURPIJA

FESTA



FESTA

RAVNA TURPIJA



Br.	Specifikacija	asperity	
22206	150 mm	2	10
22180	250 mm	2	10



FESTA

ČETVRTASTA TURPIJA



Br.	Specifikacija	asperity	
22184	250 mm	2	10



FESTA

TROUGLASTA TURPIJA



Br.	Specifikacija	asperity	
22183	250 mm	2	10



FESTA

POLUOKRUGLA TURPIJA



Br.	Specifikacija	asperity	
22207	150 mm	2	10
22182	250 mm	2	10



FESTA

TROUGLASTA TURPIJA



Br.	Specifikacija	asperity	
22178	150 mm	1	10



FESTA

OKRUGLA TURPIJA



Br.	Specifikacija	asperity	
22181	250 mm	2	10



FESTA

KOMPLET TURPIJA



5x



Br.	Specifikacija	asperity	
22209	150 mm	2	10
22186	250 mm	2	5



FESTA

KOMPLET TURPIJA



3x



Br.	Specifikacija	asperity	
22208	150 mm	2	10
22185	250 mm	2	5



FESTA

TURPIJA RAVNA ZA DRVO



Br.	Specifikacija	
22202	150 mm	10
22197	300 mm	10



FESTA

TURPIJA OKRUGLA ZA DRVO



Br.	Specifikacija	
22204	150 mm	10
22205	250 mm	10
22198	300 mm	10

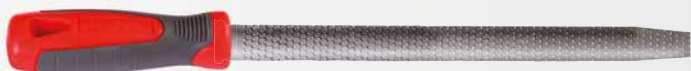

FESTA

TURPIJA POLUOKRUGLA ZA DRVO



Br.	Specifikacija	
22203	150 mm	6
22199	300 mm	6



FESTA

KOMPLET TURPIJA ZA DRVO



3x



Br.	Specifikacija	
22195	300 mm	5



FESTA

TURPIJA ZA MOTORNU TESTERU



Br.	Specifikacija		Br.	Specifikacija	
22170	200 mm 3,5 mm	10	22173	200 mm 5 mm	10
22171	200 mm 4 mm	10	22174	200 mm 5,5 mm	10
22172	200 mm 4,5 mm	10			



FESTA

KOMPLET IGLIČASTIH TURPIJA

10x



Br.	Specifikacija	
22188		20



FESTA

PRIBOR ZA BRUŠENJE LANCA



Br.	Specifikacija	
22190	300 mm	5



FESTA

KOMPLET DIJAMANTNIH TURPIJA

10x



Br.	Specifikacija	
22189		25

FESTA®

Br.	Specifikacija	tooth	
	Ø 115 mm		
22300	Ø 115 x 22 mm	40	1
	Ø 125 mm		
22301	Ø 125 x 22 mm	40	1
	Ø 140 mm		
22302	Ø 140 x 20 mm	24	1
22303	Ø 140 x 20 mm	30	1
	Ø 150 mm		
22305	Ø 150 x 20 mm	24	1
	Ø 160 mm		
22307	Ø 160 x 20 mm	18	1
22309	Ø 160 x 20 mm	24	1
22310	Ø 160 x 20 mm	30	1
22311	Ø 160 x 20 mm	36	1
22312	Ø 160 x 20 mm	48	1
22313	Ø 160 x 20 mm	60	1
	Ø 165 mm		
22314	Ø 165 x 20 mm	24	1
	Ø 180 mm		
22315	Ø 180 x 30 mm	24	1
22317	Ø 180 x 30 mm	50	1
22318	Ø 180 x 20 mm	50	1
	Ø 190 mm		
22319	Ø 190 x 20 mm	40	1
22320	Ø 190 x 30 mm	40	1
	Ø 200 mm		
22322	Ø 200 x 30 mm	24	1
22324	Ø 200 x 30 mm	40	1
22326	Ø 200 x 30 mm	60	1
	Ø 205 mm		
22328	Ø 205 x 30 mm	40	1
22329	Ø 205 x 30 mm	60	1
	Ø 210 mm		
22332	Ø 210 x 30 mm	40	1
22333	Ø 210 x 30 mm	60	1
	Ø 250 mm		
22335	Ø 250 x 30 mm	40	1
22337	Ø 250 x 30 mm	60	1
	Ø 300 mm		
22340	Ø 300 x 30 mm	40	1
22343	Ø 300 x 30 mm	60	1
22345	Ø 300 x 30 mm	96	1
	Ø 350 mm		
22350	Ø 350 x 30 mm	40	1
22351	Ø 350 x 30 mm	54	1
	Ø 400 mm		
22355	Ø 400 x 30 mm	40	1
22357	Ø 400 x 30 mm	60	1
	Ø 500 mm		
22365	Ø 500 x 30 mm	60	1
	Ø 600 mm		
22370	Ø 600 x 30 mm	60	1

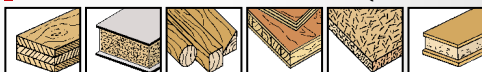
FESTA
CIRKULARNE TESTERA (ZA DRVO)

REDUKTORSKI PRSTEN

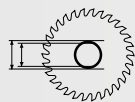
Br.	Specifikacija	
22399	Ø 20 16 mm	1
22398	Ø 30 25 mm	1







































PROFI TESTERE
PROIZVEDENE U NEMAČKOJ TEHNOLOGIJOM PALJENJA LASEROM



UBODNA TESTERA HSS - PRIČVRŠĆIVANJE BOSCH (AEG, BOSCH, FESTO, MAKITA, METABO)

	24060	50mm/1mm	0,7 mm/ 36TPI	31007	5 kom	10	
	24061	50mm/1mm	1,2 mm/ 21TPI	31012	5 kom	10	
	24062	50mm/1mm	2,0 mm/ 13TPI	31020	5 kom	10	
	24063	75mm/1mm	3,0 mm/ 8TPI	31030	5 kom	10	
	24064	100mm/1mm	1,2 mm/ 21TPI	31112	5 kom	10	
	24065	100mm/1,3mm	2,0 mm/ 13TPI	31112	5 kom	10	
	24066	75mm/1,45mm	2,0 mm/ 13TPI	31220	5 kom	10	
	24067	120mm/1,3mm	1,8 - 2,4 mm/ 10 - 14 TPI	31220	5 kom	10	
	24068	75mm/1,45mm	2,5 mm/ 10 TPI	32225	5 kom	10	
	24069	75mm/1,45mm	4 mm/ 6 TPI	32240	5 kom	10	
	24070	75mm/1,3mm	4 mm/ 6 TPI	32340	5 kom	10	
	24071	75mm/1,3mm	4 mm/ 6 TPI	32440	5 kom	10	
	24072	75mm/1,45mm	2,5 mm/ 10 TPI	32625	5 kom	10	
	24073	85mm/1,45mm	3 mm/ 8 TPI	32730	5 kom	10	
	24074	85mm/1,45mm	4 mm/ 6 TPI	32730	5 kom	10	
	32825	75mm/1,45mm	2,5 1,2 mm/10 21 TPI	32825	5 kom	10	
	24075	75mm/1,45mm	2,5 1,2 mm/10 21 TPI	32825	5 kom	10	
	24076	75mm/1,7mm	4 mm 6 TPI	32940	5 kom	10	
	24077	120mm/1,3mm	4 mm 6 TPI	32040	5 kom	10	
	24078	105mm/1,45mm	4 mm 6 TPI	34040	5 kom	10	
	24055	55mm	karbid		5 kom	1	

UBODNA TESTERA HSS - PRIČVRŠČIVANJE BLACK & DECKER (BLACK & DECKER, SKIL)

	24080	50mm 1,0 mm	1,2 21 TPI	11012	5 kom	10	   
	24081	75mm 1,0 mm	3,0 8 TPI	11030	5 kom	10	   
	24082	75mm 1,45 mm	2,5 10 TPI	12225	5 kom	10	   
	24083	75mm 1,45 mm	4 6 TPI	12240	5 kom	10	   
	24084	75mm 1,3 mm	4 6 TPI	12340	5 kom	10	  
	24085	50mm 1,0 mm	2,0 13 TPI	12420	5 kom	10	  
	24086	75mm 1,3 mm	4,0 6 TP	12440	5 kom	10	  
	24087	75mm 1,45 mm	2,5 10 TPI	12625	5 kom	10	  

	Mekani čelik (sa malom količinom ugljika)		Čelični lim		Nerdajući čelik		Laminirano drvo
	Metali bez željeza		Tvrdo i mekano drvo		Iverica		Plastika
	Šperploča		Šperploča		Drvo sa čavlima		
	Sendvič materijal		Crep		Aluminijum		

STALAK ZA PROFI UBODNE TESTERE

- Sadržaj 24098 - 24060 - 5 kom
- 24080 - 5 kom
- 24061 - 5 kom
- 24062 - 5 kom
- 24081 - 5 kom
- 24063 - 5 kom
- 24066 - 5 kom
- 24067 - 5 kom
- 24082 - 5 kom
- 24068 - 5 kom
- 24083 - 5 kom
- 24069 - 5 kom
- 24084 - 5 kom
- 24070 - 5 kom
- 24086 - 5 kom
- 24071 - 5 kom
- 24087 - 5 kom
- 24072 - 5 kom
- 24073 - 5 kom
- 24074 - 5 kom
- 24075 - 5 kom
- 24076 - 5 kom



SET UBODNIH TESTERA



5x		
Br.	Specifikacija	
24045	sada	50

Br.	Specifikacija	
24099	64 x 50 cm - Prazan	1
24098	64 x 50 cm - Sa ubodnim testerama	1

FESTA

UBODNA TESTERA

HCS 3x

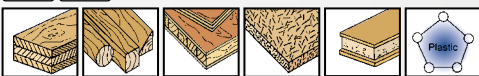

Br. 24301 Specifikacija 150 x 19 x 1,3 mm TPI 6

1

FESTA

UBODNA TESTERA

HCS 3x

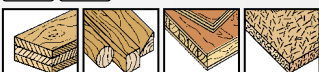

Br. 24302 Specifikacija 225 x 19 x 1,3 mm TPI 3

1

FESTA

UBODNA TESTERA

HCS 3x

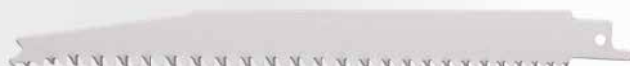
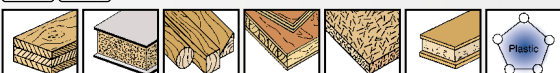

Br. 24303 Specifikacija 200 x 19 x 1,3 mm TPI 6 - 10

1

FESTA

UBODNA TESTERA

HCS 3x

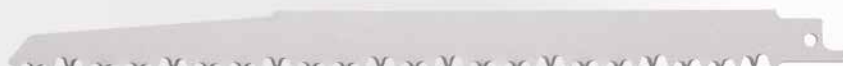

Br. 24304 Specifikacija 240 x 19 x 1,5 mm TPI 5

1

FESTA

UBODNA TESTERA

Bi Metal 3x

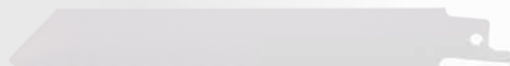
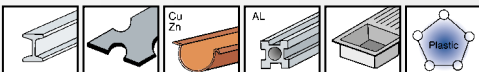

Br. 24305 Specifikacija 150 x 19 x 1 mm TPI 24

1

FESTA

UBODNA TESTERA

Bi Metal 3x

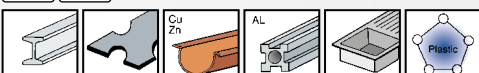

Br. 24306 Specifikacija 150 x 19 x 1 mm TPI 9

1

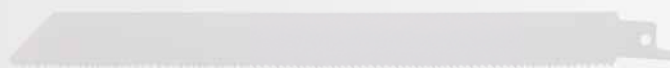
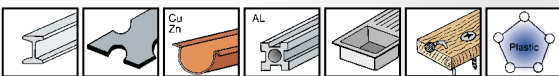
FESTA**UBODNA TESTERA****Bi Metal** **3x**

Br.	Specifikacija
24308	225 x 19 x 1 mm TPI 10 - 14

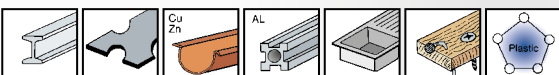
**FESTA****UBODNA TESTERA****Bi Metal** **3x**

Br.	Specifikacija
24310	150 x 22 x 1,6 mm TPI 9

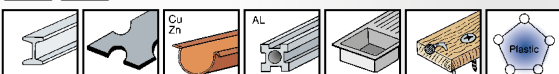
**FESTA****UBODNA TESTERA****Bi Metal** **3x**

Br.	Specifikacija
24313	225 x 22 x 1,6 mm TPI 6

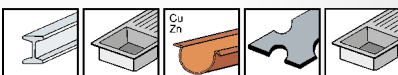
**FESTA****METALNA TESTERA HSS****HSS**

Br.	Specifikacija
24050	203 x 19 x 1 mm TPI 10 - 14

**FESTA****UBODNA TESTERA**

· Karbidna tehnologija

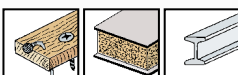
TC **3x**

Br.	Specifikacija
24312	225 x 19 x 1,3 mm TPI 6 - 9

**FESTA****UBODNA TESTERA****TC**

Br.	Specifikacija
24315	305 x 50 x 1,5 mm
24316	455 x 50 x 1,5 mm



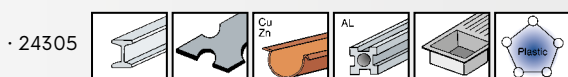
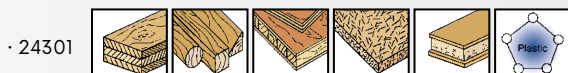

FESTA

SET UBODNIH TESTERA

Bi Metal HCS 3x



Br. 24314 Specifikacija



1



LIST TESTERE

· Termički ojačani zubi



Br.	Specifikacija	
24185	533 mm	1
24186	610 mm	1
24187	760 mm	1
24188	800 mm	1
24189	914 mm	1



FESTA

LIST TESTERE

· Termički ojačani zubi



Br.	Specifikacija	
24169	350 mm	10
24167	450 mm	10
24166	533 mm	10
24163	610 mm	10
24164	760 mm	10
24168	800 mm	10
24165	914 mm	10



LIST TESTERE



Br.	Specifikacija	
24195	šipka 3 mm 300 mm	1
24196	šipka 4 mm 300 mm Kosi zubi	1
24197	šipka 5 mm 300 mm Termički ojačani zubi	1
24192	List za testere 24128 - 450 mm	1



LIST TESTERE

Br.	Specifikacija	
24160	šipka 3 mm 300 mm	20
24161	šipka 4 mm 300 mm	20
24162	šipka 5 mm 300 mm	50



LIST BONSEKA

10x



Br.	Specifikacija	
24108	6 mm 150 mm	1



REZNA STRUNA



Br.	Specifikacija	
24120	300 mm	50

**FESTA****LIST BONSEKA BI-METAL**

· 8 % COBALT



Br.	Specifikacija
24180	300 mm

125

FESTA**LIST BONSEKA**

MOQ

Br.	Specifikacija		
24109	12,5 mm 300 mm	Za metal	144
24118	25 mm 300 mm	Za metal obostrana	72
24119	25 mm 300 mm	Za metal, drvo	72

FESTA**BONSEK**

Br.	Specifikacija
24104	300 mm

6

FESTA**BONSEK**

· Ojačani ram



Br.	Specifikacija
24102	300 mm

6

BONSEK

Br.	Specifikacija
24153	300 mm

12

BONSEK

Br.	Specifikacija
24100	300 mm

12



BONSEK



Br.	Specifikacija	
24170	300 mm	12



FESTA

BONSEK



2x



Br.	Specifikacija	
24126	300 x 25 x 0,65 mm TPI 24 14	10



BONSEK

· List testere 24108



Br.	Specifikacija	
24125	150 mm	6



BONSEK

· List testere 24109



Br.	Specifikacija	
24124	260 mm	12



BONSEK



Br.	Specifikacija	
24121	bosnek	12
24110	list testere	30

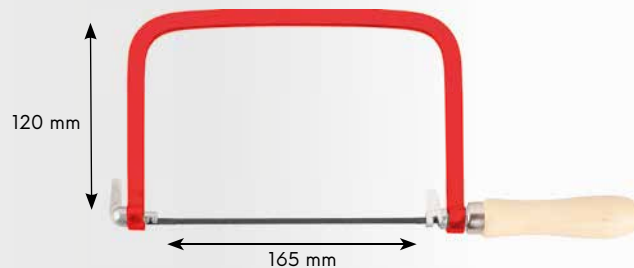

BONSEK

· 5x list testere



Br.	Specifikacija	
24122	bosnek	20
24111	list testere	30

FESTA

RUČNA TESTERA PVC DRŠKA

TEFLON



Trostrano naoštreni zubi, termički ojačani zubi



Br.	Specifikacija	
24143	300 mm	12
24144	400 mm	12
24145	500 mm	12

**FESTA**

TESTERA FUSMANS STOLARSKI

TEFLON



Trostrano naoštreni zubi, termički ojačani zubi

Br.	Specifikacija	
24147	300 mm	6

FESTA

TESTERA ŠPICASTA



Trostrano naoštreni zubi, termički ojačani zubi



Br.	Specifikacija	
24149	300 mm	12

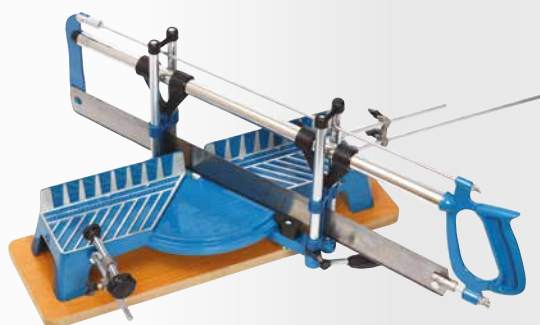

TESTERA UGAONA PROFI



Br.	Specifikacija	
24130	600 mm	1
24131	600 mm, list testere	1



ŠABLON ZA SEČENJE



Br.	Specifikacija	
24133	300 x 140 mm	18



ŠABLON ZA SEČENJE

Buk
MADE IN
EU

Br.	Specifikacija	
24171	80 x 300 mm	10



TESTERA UGAONA



Br.	Specifikacija	
24148	300 mm	25



FESTA

TESTERA U MET. RAMU

• Termički ojačani zubi

Br.	Specifikacija		Br.	Specifikacija	
24141	450 mm	12	24136	760 mm	12
24140	533 mm	12	24142	800 mm	12
24135	610 mm	12	24137	914 mm	12



FESTA

TESTERA U MET. RAMU

• Termički ojačani zubi

Br.	Specifikacija	
24173	350 mm	24

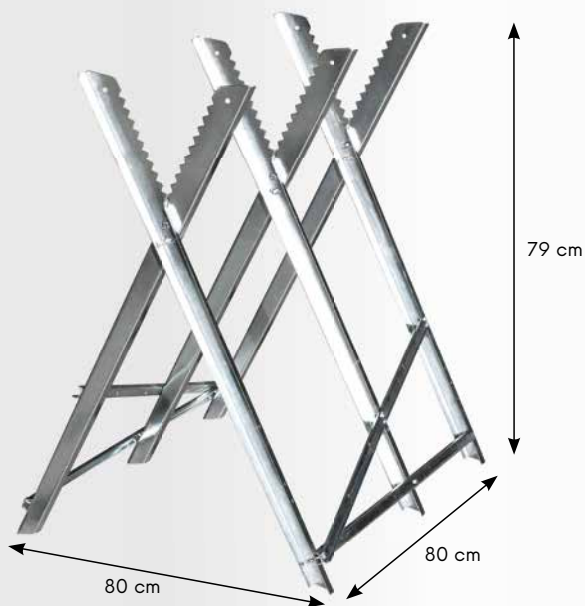

STALAK ZA SEČENJE DRVETA



Br.	Specifikacija	
37570	max. 150 kg	3



TESTERA BONSEK



Br.	Specifikacija	
24151	300 mm	10

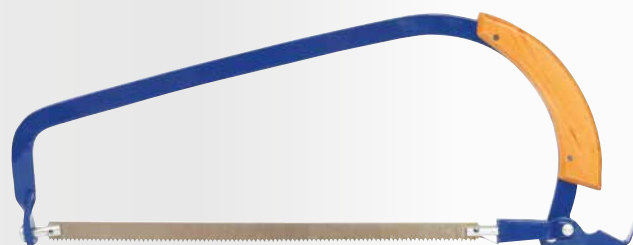

TESTERA ZA GRANE



Br.	Specifikacija	
24150	300 mm	5

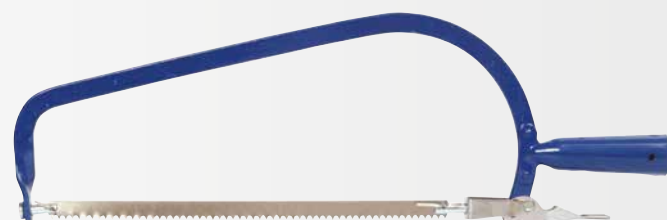

TESTERA VRTNA



Br.	Specifikacija	
24154	300 mm	10



TESTERA

Br.	Specifikacija	
24128	450 mm list 24192	6

**FESTA****PREKLOPNA TESTERA**
 · Trostrano naoštreni zubi, termički ojačani zubi



Br.	Specifikacija
45061	150 mm with cover of handle

12

**FESTA****TESTERA ZA GRANE PREKLOPNA**
 · Trostrano naoštreni zubi, termički ojačani zubi



Br.	Specifikacija
45060	180 mm

6

**FESTA****TESTERA ZA GRANE**
 · Trostrano naoštreni zubi, termički ojačani zubi



Br.	Specifikacija
45062	260 mm with case

24

**FESTA****TESTERA ZA GRANE**
 · Trostrano naoštreni zubi, termički ojačani zubi

Br.	Specifikacija
24152	350 mm 7 tpi

12

**FESTA****TELESKOPSKA TESTERA**
 · Trostrano naoštreni zubi, termički ojačani zubi

Br.	Specifikacija
45033	230 - 490 mm

1

**TESTERA ZA GRANE SA KANAPOM**

Br.	Specifikacija
45030	pilka 30 cm Teleskopska mjerna šipka 260 cm
45031	pilka 30 cm

6

6

**TESTERA ZA GRANE SA KANAPOM**

Br.	Specifikacija
45032	Metalna bez pile

6

6



FESTA®
TESTERA ZA POLIESTER

Br.	Specifikacija	
24174	370 mm	1



FESTA®
TESTERA ZA GIPSANE PLOČE



Trostrano naoštreni zubi, termički ojačani zubi



Br.	Specifikacija	
24159	150 mm	12



BOSNEK ZA GIP. PLOČE



Br.	Specifikacija	
24190	270 mm	10



FESTA®
TESTERA ZA OPEKE



Br.	Specifikacija	
24181	550 mm	1



FESTA®
TESTERA VIDIJUM



Br.	Specifikacija	
24158	22 22 SK zuba - 450 mm	5



FESTA®
TESTERA VIDIJUM



Br.	Specifikacija	
24155	34 17 SK zuba - 630 mm	2
24156	34 34 SK zuba - 630 mm	2



FESTA®
TESTERA VIDIJUM

Br.	Specifikacija	
24176	34 17 SK zuba - 750 mm	6
24177	34 34 SK zuba - 750 mm	6



FESTA®
TESTERA VIDIJUM





Termički ojačani zubi



Br.	Specifikacija	
24175	bez SK zuba - 600 mm EU	2
24178	bez SK zuba - 600 mm	6

FESTA®



Using cutting diamond blades				
materials	festa industry	full	turbo	segment
Cigla	••	••	••	••
Pločica	••	•••	••	-
Kamen	••	••	••	••
Beton	•••	•	•••	•••
Ojačani beton	-	-	•••	-
Crijep	••	•	••	••
Staklo, keramika	-	•••	-	-
Mramor	•	••	•	•
Granit	•••	••	•••	••
Pješčar	••	-	••	••
Asfalt	-	••	-	••
Kvarc	••	•	••	•



FESTA
INDUSTRY

DIJAM. REZ. PLOČA

Br.	Specifikacija			
21200	Ø 115 mm	1,4 mm	Ø 22,2 mm	1
21201	Ø 125 mm	1,4 mm	Ø 22,2 mm	1
21204	Ø 200 mm	1,8 mm	Ø 25,4 mm	1
21203	Ø 230 mm	1,8 mm	Ø 22,2 mm	1

FESTA

DIJAM. REZ. PLOČA PUNE

Br.	Specifikacija		
21210	Ø 110 mm	Ø 22,2 mm	1
21211	Ø 115 mm	Ø 22,2 mm	1
21212	Ø 125 mm	Ø 22,2 mm	1
21215	Ø 150 mm	Ø 22,2 mm	1
21218	Ø 180 mm	Ø 22,2 mm	1
21219	Ø 180 mm	Ø 25,4 mm	1
21220	Ø 200 mm	Ø 25,4 mm	1
21223	Ø 230 mm	Ø 22,2 mm	1
21224	Ø 300 mm	Ø 25,4 mm	1

**FESTA**

DIJAM. REZ. PLOČA SEGMENT

Br.	Specifikacija			
21311	Ø 115 mm	Ø 22,2 mm		1
21312	Ø 125 mm	Ø 22,2 mm		1
21315	Ø 150 mm	Ø 22,2 mm		1
21318	Ø 180 mm	Ø 22,2 mm		1
21323	Ø 230 mm	Ø 22,2 mm		1
21324	Ø 300 mm	Ø 25,4 mm		1
21327	Ø 350 mm	Ø 25,4 mm		1
21326	Ø 400 mm	Ø 25,4 mm		1

**FESTA**

DIJAM. REZ. PLOČA TURBO

Br.	Specifikacija			
21410	Ø 110 mm	Ø 22,2 mm		1
21411	Ø 115 mm	Ø 22,2 mm		1
21412	Ø 125 mm	Ø 22,2 mm		1
21415	Ø 150 mm	Ø 22,2 mm		1
21418	Ø 180 mm	Ø 22,2 mm		1
21423	Ø 230 mm	Ø 22,2 mm		1
21424	Ø 300 mm	Ø 25,4 mm		1

**FESTA**

DIJAM. REZ. PLOČA SEGMENT - UNIVERZALNI



Br.	Specifikacija				
21301	Ø 125 mm	Ø 22,2 mm	1,5 mm		1
21303	Ø 230 mm	Ø 22,2 mm	1,8 mm		1

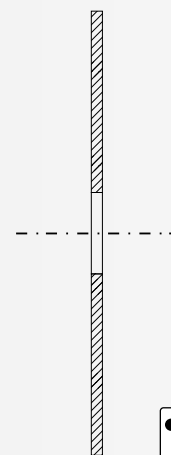

DIJAM. REZ. PLOČA PUNE

Br.	Specifikacija		
21010	Ø 110 mm Ø 22,2 mm		1
21011	Ø 115 mm Ø 22,2 mm		1
21012	Ø 125 mm Ø 22,2 mm		1
21015	Ø 150 mm Ø 22,2 mm		1
21018	Ø 180 mm Ø 22,2 mm		1
21023	Ø 230 mm Ø 22,2 mm		1

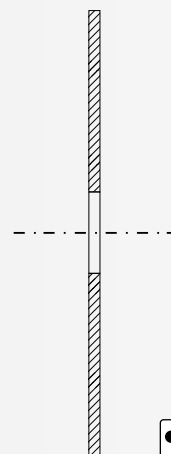

DIJAM. REZ. PLOČA SEGMENT

Br.	Specifikacija		
21110	Ø 110 mm Ø 22,2 mm		1
21111	Ø 115 mm Ø 22,2 mm		1
21112	Ø 125 mm Ø 22,2 mm		1
21115	Ø 150 mm Ø 22,2 mm		1
21118	Ø 180 mm Ø 22,2 mm		1
21123	Ø 230 mm Ø 22,2 mm		1

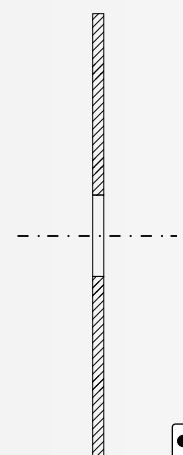

DIJAM. REZ. PLOČA TURBO

Br.	Specifikacija		
21130	Ø 110 mm Ø 22,2 mm		1
21135	Ø 115 mm Ø 22,2 mm		1
21140	Ø 125 mm Ø 22,2 mm		1
21150	Ø 150 mm Ø 22,2 mm		1
21180	Ø 180 mm Ø 22,2 mm		1
21190	Ø 230 mm Ø 22,2 mm		1



FESTA

DIJAM. BRUSNA PLOČA



Br.	Specifikacija		
21430	Ø 115 mm	Ø 22,2 mm	1
21431	Ø 125 mm	Ø 22,2 mm	1
21432	Ø 150 mm	Ø 22,2 mm	1



FESTA

DIJAM. BRUSNA PLOČA



Br.	Specifikacija		
21425	Ø 100 mm	Ø 22,2 mm	1
21426	Ø 115 mm	Ø 22,2 mm	1
21427	Ø 125 mm	Ø 22,2 mm	1
21428	Ø 150 mm	Ø 22,2 mm	1



6 mm



FESTA

DIJAM. REZ. PLOČA



Br.	Specifikacija	
21195	Ø 125 x 22,2 mm	1

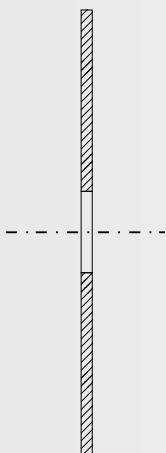

NEW



FESTA

REZNA PLOČA ZA METAL



Br.	Specifikacija			
22211	Ø 115 mm	Ø 22,2 mm x 1 mm	INOX	50
22212	Ø 115 mm	Ø 22,2 mm x 1,2 mm	INOX	50
22225	Ø 125 mm	Ø 22,2 mm x 1 mm	INOX	50
22217	Ø 125 mm	Ø 22,2 mm x 1,2 mm	INOX	50

Br.	Specifikacija			
22251	Ø 115 mm	Ø 22,2 mm x 1,6 mm		50
22215	Ø 115 mm	Ø 22,2 mm x 2 mm		50
22216	Ø 115 mm	Ø 22,2 mm x 2,5 mm		50
22252	Ø 125 mm	Ø 22,2 mm x 1,6 mm		25
22218	Ø 125 mm	Ø 22,2 mm x 2,5 mm		25
22219	Ø 150 mm	Ø 22,2 mm x 1,2 mm		25
22253	Ø 150 mm	Ø 22,2 mm x 1,6 mm		50
22220	Ø 150 mm	Ø 22,2 mm x 2,5 mm		50
22254	Ø 180 mm	Ø 22,2 mm x 1,6 mm		50
22222	Ø 180 mm	Ø 22,2 mm x 2,5 mm		25
22255	Ø 230 mm	Ø 22,2 mm x 1,6 mm		25
22224	Ø 230 mm	Ø 22,2 mm x 2,5 mm		25

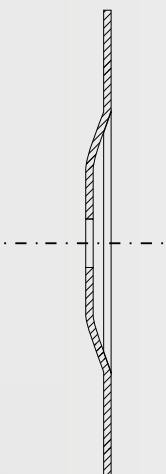

FESTA

BRUSNA PLOČA ZA METAL



Br.	Specifikacija			
22240	Ø 115 mm	Ø 22,2 mm x 6,4 mm		25
22242	Ø 125 mm	Ø 22,2 mm x 6,4 mm		25
22244	Ø 150 mm	Ø 22,2 mm x 6,4 mm		25
22246	Ø 180 mm	Ø 22,2 mm x 6,4 mm		25
22248	Ø 230 mm	Ø 22,2 mm x 6,4 mm		25

FESTA

REZNA PLOČA ZA METAL

10x

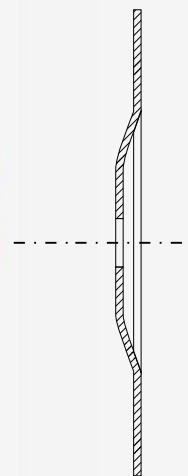

Br.	Specifikacija			
22228	Ø 115 mm	Ø 22,2 mm x 1 mm		6
22229	Ø 125 mm	Ø 22,2 mm x 1,2 mm		6

FESTA
INDUSTRY

REZNA PLOČA ZA METAL



MADE IN EU oSA

Br.	Specifikacija			
22258	NEW	Ø 115 mm	Ø 22,2 mm x 0,8 mm	25
22260		Ø 115 mm	Ø 22,2 mm x 1 mm	25
22263		Ø 115 mm	Ø 22,2 mm x 1,6 mm	25
22264	NEW	Ø 115 mm	Ø 22,2 mm x 2 mm	25
22259		Ø 125 mm	Ø 22,2 mm x 0,8 mm	25
22266		Ø 125 mm	Ø 22,2 mm x 1 mm	25
22269		Ø 125 mm	Ø 22,2 mm x 1,6 mm	25
22270		Ø 125 mm	Ø 22,2 mm x 2 mm	25
22273		Ø 150 mm	Ø 22,2 mm x 1,6 mm	25
22274		Ø 150 mm	Ø 22,2 mm x 2 mm	25
22275		Ø 150 mm	Ø 22,2 mm x 2,5 mm	25
22277		Ø 180 mm	Ø 22,2 mm x 2 mm	25
22280		Ø 230 mm	Ø 22,2 mm x 2 mm	25
22281		Ø 230 mm	Ø 22,2 mm x 2,5 mm	25

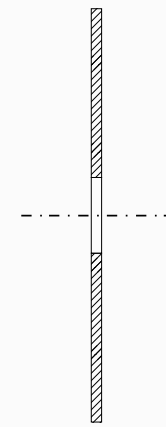
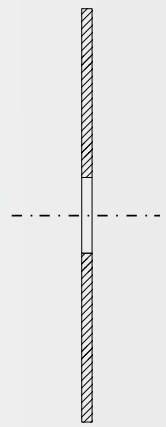

FESTA
INDUSTRY

REZNA PLOČA ZA ALUMINIJUM

ALU



Br.	Specifikacija		
22285	Ø 115 mm Ø 22,2 mm x 1 mm		25
22286	Ø 125 mm Ø 22,2 mm x 1 mm		25

FESTA

DIJAM. REZ. PLOČA ZA METAL

INOX ALU



Br.	Specifikacija		
21306	Ø 125 mm Ø 22,2 mm 1,3 mm		25
21308	Ø 230 mm Ø 22,2 mm 1,8 mm		5

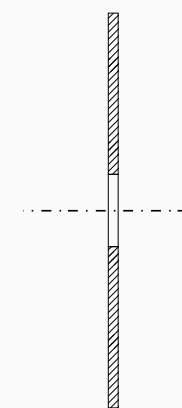

FESTA

REZNA PLOČA UNIVERZALNI - KARBID



Br.	Specifikacija		
21192	Ø 125 mm Ø 22,2 mm		25
21194	Ø 230 mm Ø 22,2 mm		5

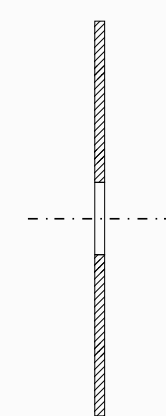
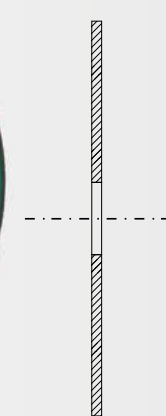

FESTA
INDUSTRY

REZNA PLOČA ZA KAMEN



Br.	Specifikacija		
22294	Ø 230 mm Ø 22,2 mm x 3 mm		25

FESTA

REZNA PLOČA ZA KAMEN



Br.	Specifikacija		
22230	Ø 115 mm Ø 22,2 mm x 2,5 mm		50
22232	Ø 125 mm Ø 22,2 mm x 2,5 mm		50
22234	Ø 150 mm Ø 22,2 mm x 2,5 mm		25
22236	Ø 180 mm Ø 22,2 mm x 2,5 mm		25
22238	Ø 230 mm Ø 22,2 mm x 2,5 mm		25

NEW

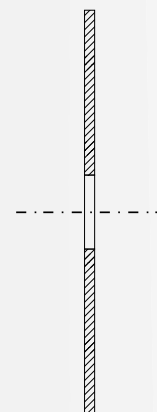

REZNA PLOČA ZA DRVETA



Br.	Specifikacija				
21804	Ø 125 mm	Ø 22,2 mm	14T		1

NEW

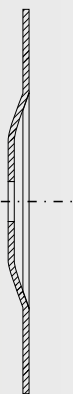

FESTA

DISK ZA BRUŠENJE DRVETA



Br.	Specifikacija				
21803	Ø 125 mm	Ø 22,2 mm			1

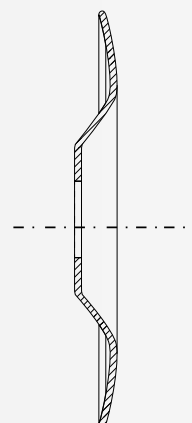

FESTA

DISK ZA BRUŠENJE DRVETA - SREDNJE GRUBO



Br.	Specifikacija				
21802	Ø 125 mm	Ø 22,2 mm	3 mm		10



FESTA

DISK ZA BRUŠENJE DRVETA - GRUBO



Br.	Specifikacija				
21801	Ø 125 mm	Ø 22,2 mm	3 mm		10

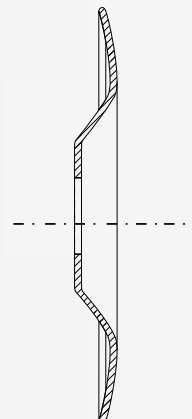

FESTA

DISC DRVO SA RUPAMA

· Za brušenje drva



Br.	Specifikacija				
21800	Ø 125 mm	Ø 22,2 mm			1

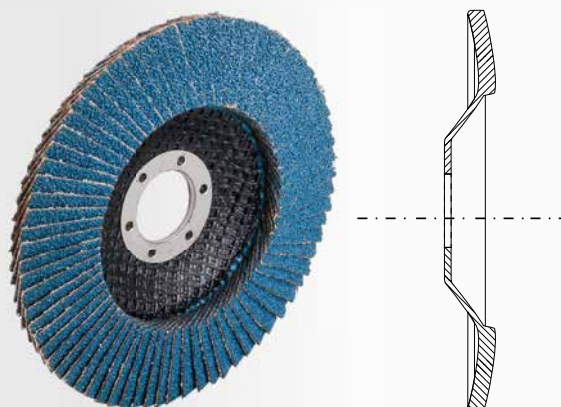
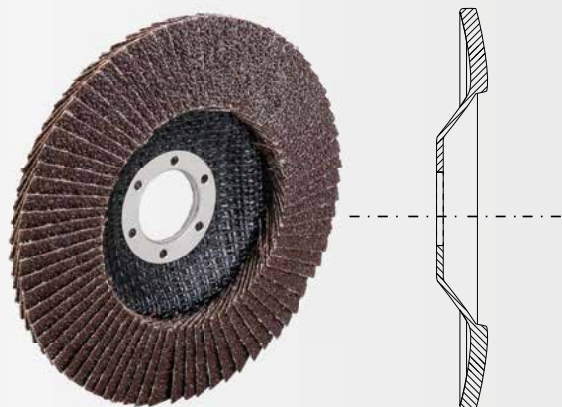

LAMELNI-DISK



Br.	Specifikacija		asperity	
21780	Ø 115 mm	Ø 22,2 mm	P40	10
21781	Ø 115 mm	Ø 22,2 mm	P60	10
21782	Ø 115 mm	Ø 22,2 m	P80	10
21783	Ø 115 mm	Ø 22,2 mm	P100	10
21784	Ø 115 mm	Ø 22,2 mm	P120	10
21786	Ø 125 mm	Ø 22,2 mm	P40	10
21787	Ø 125 mm	Ø 22,2 mm	P60	10
21788	Ø 125 mm	Ø 22,2 mm	P80	10
21789	Ø 125 mm	Ø 22,2 mm	P100	10
21790	Ø 125 mm	Ø 22,2 mm	P120	10
21792	Ø 150 mm	Ø 22,2 mm	P40	10
21793	Ø 150 mm	Ø 22,2 mm	P60	10
21794	Ø 150 mm	Ø 22,2 mm	P80	10
21795	Ø 150 mm	Ø 22,2 mm	P100	10
21796	Ø 150 mm	Ø 22,2 mm	P120	10

FESTA

LAMELNI-DISK

· Za brušenje nerđajućeg čelika



Br.	Specifikacija		asperity	
22140	Ø 115 mm	Ø 22,2 mm	P40	5
22141	Ø 115 mm	Ø 22,2 mm	P60	5
22142	Ø 115 mm	Ø 22,2 mm	P80	5
22143	Ø 115 mm	Ø 22,2 mm	P100	5
22145	Ø 125 mm	Ø 22,2 mm	P40	5
22146	Ø 125 mm	Ø 22,2 mm	P60	5
22147	Ø 125 mm	Ø 22,2 mm	P80	5
22148	Ø 125 mm	Ø 22,2 mm	P100	5
22150	Ø 150 mm	Ø 22,2 mm	P40	5
22151	Ø 150 mm	Ø 22,2 mm	P60	5
22155	Ø 150 mm	Ø 22,2 mm	P80	5
22156	Ø 150 mm	Ø 22,2 mm	P100	5



ČETKA NAJLON ZA POLIRANJE



Br.	Specifikacija	
21798	Ø 125 mm Ø 22,2 mm	1



GLETERICE, SPAHLE



FANGLE



STRUGALICA



GLETERICE DRVENE



GLETERICE PLASTIČNE



MEŠAČI



PRODUŽNI KABLOVI

ELEKTRIČNI I GASNI
GREJAČI

MEŠALICE

PUNILAC GRADJEVINSKIM
OTPADOM

GRAĐEVINSKA KOLICA



DRŽAČ IVIČNJAKA



REZAČI PLOČICA

ALATI ZA POLAGANJE
PLOČICA

NIVELING PRIBOR



293

KAJLE I SITA



298

FASADERSKA MAŠINA



300

BRENERI I REGULATORI



304

KANTE I POSUDE ZA GIPS

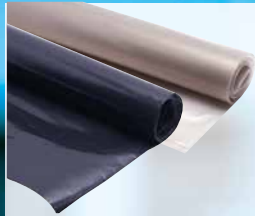

305

KESA ZA DJUBRE



306

IZOLIR TRAKE PVC



310

PIŠTOLJ ZA SILIKON



313

PIŠTOLJ ZA PUR



314

PIŠTOLJI ZA LEPLJENJE

GRAĐEVINSKI ALAT 242 - 329



316

ČETKA I VALJAK ZA FARBANJE



322

PE FOLIJA



324

LANCI, SAJLE



327

SVETILJKE – REFLEKTORI



328

MERDEVINE



328

STUBOVI, VRATA ZA DIMNJAK

GLETARICE, ŠPAKLE, MISTRIJE



FESTA

GLETARICA GLATKA 280 X 130 MM

· Gumena drška



Br.	Specifikacije	
31140	Glatka	10



FESTA

GLETARICA GLATKA 280 X 130 MM

· Gumena drška



Br.	Specifikacije	
31148	Glatka	10



FESTA

GLETARICA 280 X 130 MM NAZUBLJENA

· Gumena drška



Br.	Specifikacije	
31146	Ø 16	10



FESTA

GLETARICA 280 X 130 MM NAZUBLJENA

· Gumena drška



Br.	Specifikacije		Br.	Specifikacije	
31141	e 4	10	31144	e 10	10
31142	e 6	10	31145	e 12	10
31143	e 8	10			



FESTA

GLETARICA 280 X 130 MM NAZUBLJENA



Br.	Specifikacije		Br.	Specifikacije	
31101	e 4	10	31131	e 10	10
31111	e 6	10	31132	e 12	10
31121	e 8	10			



FESTA

GLETARICA 280 X 130 MM



Br.	Specifikacije	
31091	Glatka	10



FESTA

GLETARICA 280 X 130 MM



Br.	Specifikacije	
31011	Glatka	10



FESTA

GLETARICA 280 X 130 MM NAZUBLJENA



Br.	Specifikacije		Br.	Specifikacije	
31021	e 4	10	31051	e 10	10
31031	e 6	10	31053	e 12	10
31041	e 8	10			



GLETARICA 270 X 125 MM



Br.	Specifikacije	
31005	Glatka	25



GLETARICA 270 X 125 MM NAZUBLJENA



Br.	Specifikacije		Br.	Specifikacije	
31006	e 4	24	31008	e 8	24
31007	e 6	24	31009	e 10	24



FESTA

GLETARICA 360 X 130 MM



Br.	Specifikacije	
31151	Glatka	10



FESTA

GLETARICA 360 X 130 MM



Br.	Specifikacije	
31150	Glatka	10



FESTA

GLETARICA 480 X 130 MM



Br.	Specifikacije	
31082	Glatka	10



FESTA

GLETARICA 680 X 130 MM



Br.	Specifikacije	
31155	Glatka	10

**FESTA**

GLETARICA GLATKA 500 X 130 MM

INOX

Br.	Specifikacije	
31081	Glatka	10

**FESTA**

GLETARICA NAZUBLJENA

INOX

Br.	Specifikacije	
31052	e 4	10
31061	e 6	10
31062	e 8	10
31071	e 10	10
31072	e 12	10

**FESTA**

MISTRINJA ROST FREI, GUMENA DRŠKA

· Gumena drška

INOX

Br.	Specifikacije		Br.	rozméry	
31232	120 mm	10	31234	160 mm	10
31233	140 mm	10	31235	180 mm	10

**FESTA**

MISTRINJA ROST FREI

INOX

Br.	Specifikacije		Br.	Specifikacije	
31220	120 x 80 mm	10	31222	160 x 115 mm	10
31221	140 x 80 mm	10	31231	180 x 120 mm	10

**FESTA**MISTRINJA OKRUGLA ROST FREI,
GUMENA DRŠKA

· Gumena drška

INOX

Br.	Specifikacije	
31334	160 x 100 mm	10

**FESTA**

MISTRINJA OKRUGLA ROST FREI

INOX

Br.	Specifikacije	
31343	160 x 100 mm	10

**FESTA**MISTRINJA ZIDARSKA ROST FREI,
GUMENA DRŠKA

· Gumena drška

INOX

Br.	Specifikacije		Br.	Specifikacije	
31360	40 mm	10	31400	100 mm	10
31380	60 mm	10	31403	120 mm	10
31390	80 mm	10			

**FESTA**

MISTRINJA ZIDARSKA ROST FREI

INOX

Br.	Specifikacije		Br.	Specifikacije	
31362	40 mm	10	31392	80 mm	10
31382	60 mm	10	31402	100 mm	10
			31404	120 mm	10



FESTA

MISTRIJA OKRUGLA ROST FREI,
GUMENA DRŠKA

· Gumena drška

INOX

Br.	Specifikacije	
31330	140 x 50 mm	10
31340	160 x 60 mm	10



FESTA

MISTRIJA OKRUGLA ROST FREI

INOX

Br.	Specifikacije	
31332	140 x 50 mm	10
31341	160 x 60 mm	10



FESTA

MISTRIJA UGAONA ROST FREI,
GUMENA DRŠKA

· Gumena drška

INOX

Br.	Specifikacije	
31280	80 x 60 x 60 mm	10



FESTA

MISTRIJA UGAONA ROST FREI

INOX

Br.	Specifikacije	
31281	80 x 60 x 60 mm	10



FESTA

MISTRIJA UGAONA ROST FREI,
GUMENA DRŠKA

· Gumena drška

INOX

Br.	Specifikacije	
31270	80 x 60 x 60 mm	10



FESTA

MISTRIJA UGAONA ROST FREI

INOX

Br.	Specifikacije	
31271	80 x 60 x 60 mm	10



FESTA

MISTRIJA ŠPICASTA ROST FREI,
GUMENA DRŠKA

· Gumena drška

INOX

Br.	Specifikacije	
31320	140 x 75 mm	10



FESTA

MISTRIJA ŠPICASTA ROST FREI

INOX

Br.	Specifikacije	
31322	140 x 75 mm	10

**FESTA**

MISTRIJA KOCKASTA

INOX

Br.	Specifikacije	
31218	180 mm e 6	12

**FESTA**

ŠPAKLA ROST FREI

INOX

Br.	Specifikacije		Br.	Specifikacije	
31461	40 mm	12	31491	100 mm	12
31471	60 mm	12	31467	120 mm	12
31481	80 mm	12	31468	140 mm	12



2 mm

**FESTA**

STRUGALICA, NAOŠTRENIH IVICA

- Držaljke 52010
- Ojačana sečiva

INOX

Br.	Specifikacije	
32170	100 mm	12

**FESTA**

ŠPAKLA ROST FREI, GUMENA DRŠKA

- Gumena drška

INOX

Br.	Specifikacije		Br.	Specifikacije	
31510	40 mm	10	31513	100 mm	10
31511	60 mm	10	31514	120 mm	10
31512	80 mm	10	31515	140 mm	10

**FESTA**

STRUGALICA, NAOŠTRENIH IVICA

- Gumena drška
- Ojačana sečiva

INOX

Br.	Specifikacije	
32173	75 mm	10



2 mm

**FESTA**

ŠPAKLA, BIT

- Gumena drška

INOX

Br.	Specifikacije	
31455	150 mm	12
31456	200 mm	12

bit PH2

**FESTA**

ŠPAKLA FASADNA POJAČANA

- Gumena drška

INOX

Br.	Specifikacije	
31505	200 mm	5
31506	250 mm	5
31507	300 mm	5



FESTA

ŠPAKLA ZA ZAPTIVANJE NA CELOJ POVRŠINI

INOX

Br.	Specifikacije	
31555	35 cm	1
31556	45 cm	1
31557	60 cm	1

Br.	Specifikacije	
31558	80 cm	1
31559	100 cm	1

NEW



FESTA

DRŽAČ LOPATICE
ZA ZAPTIVANJE CELE POVRŠINE

za 31555 - 31559

ručka 52010, 52011, 52012, 52020, 52030

Br.	Specifikacije	
31610		1

NEW

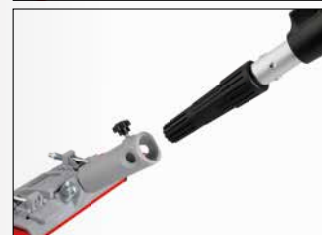

FESTA

TELESKOPSKA RUČKA

konac za 31610, 34203

Br.	Specifikacije	
52011	88 - 140 cm	1



LOPATICA NEHRĐAJUĆI ČELIK S POJAČANJEM

INOX

MADE IN
EU

Br.	Specifikacije	
31520	400 mm	1
31521	500 mm	
31522	600 mm	



31523

ručka 61254



31524

LOPATJICA NEHRĐAJUĆI ČELIK S POJAČANJEM - PRIBOR

MADE IN
EU

Br.	Specifikacije	
31523	ALU ručka	1
31524	plastična ručka	1



FESTA

ŠPAKLA FASADNA ROST FREI

INOX

Br.	Specifikacije	
31552	400 mm	10
31553	600 mm	10



ŠPAKLA FASADNA ROST FREI

INOX

MADE IN
EU

Br.	Specifikacije	
31541	250 mm	1
31551	250 mm Uska	1



FESTA

ŠPAKLA ROST FREI

INOX

Br.	Specifikacije	
31498	150 mm	12
31499	200 mm	12
31500	100 mm	12



ŠPAKLA TVRDA ROST FREI

INOX

MADE IN
EU

Br.	Specifikacije	
31493	40 mm	20
31494	60 mm	20
31495	80 mm	20
31496	100 mm	20



FESTA

ŠPAKLA

Br.	Specifikacije	
32161	30 mm	10
32162	40 mm	10
32163	50 mm	10
32164	60 mm	10
32169	70 mm	10
32165	80 mm	10



FESTA

STRUGALICA, NAOSTRENIH IVICA

· Ojačana sečiva

INOX

Br.	Širina	Dužina	
32174	100 mm	500 mm	1



ŠPAKLA

Br.	Specifikacije	
32176	30 mm	12
32186	40 mm	12
32196	50 mm	12
32206	60 mm	12

Br.	Specifikacije	
32216	80 mm	12
32226	100 mm	12
32234	125 mm	12

ŠPAKLA KOMPLET

3x

Br.	Specifikacije	
32240	30, 50, 80 mm	10





GLETARICA GLATKA CRNA

Br.	Specifikacije	
32062	280 x 160 mm	10
32076	400 x 100 mm	36
32060	500 x 140 mm	5



GLETARICA GLATKA ŠPICASTA

Br.	Specifikacije	
32064	500 x 90 mm	5
32066	550 x 140 mm	5



MISTRIJA

Br.	Specifikacije	
32015	160 x 130 mm	10
32014	180 x 130 mm	10
32016	200 x 140 mm	10



MISTRIJA KOCKASTA

Br.	Specifikacije	
32001	160 x 110 mm	10
32002	160 x 130 mm	10
32003	180 x 130 mm	10
32013	200 x 140 mm	10



Br.	Specifikacije	
32018	160 x 110 mm	10

Br.	Specifikacije	
32024	140 x 80 mm	12



MISTRIJA OKRUGLA

Br.	Specifikacije	
32020	140 x 65 mm	12
32021	140 x 40 mm	12



MISTRIJA

Br.	Specifikacije	
32026	140 x 85 mm	12



FESTA

FANGLA ROST FREI

INOX

Br.	Specifikacije	
32285	Ø 180 mm	1



FESTA

FANGLA

Zn

Br.	Specifikacije	
32265	Ø 180 mm	10



FESTA

FANGLA CRNA

Br.	Specifikacije	
32273	Ø 160 mm	10
32283	Ø 180 mm	10
32293	Ø 215 mm	10



FANGLA PLASTIČNA



Br.	Specifikacije	
32270	Ø 160 mm	1



KUTLAČA ZA MALTER

· Pogodna drška 61215

Br.	Specifikacije	
32302	Ø 180 mm	1
32313	Ø 215 mm	1
32301	Ø 235 mm	1



KUTLAČA ZA MALTER

· Pogodna drška 61200, 61201

Br.	Specifikacije	
32268	Ø 215 mm	1
32269	Ø 235 mm	1
32296	Ø 215 mm	1



KUTLAČA ZA MALTER SA DRŽALJOM

MOQ 3

Br.	Specifikacije	
32295	Ø 180 mm držalje 160 cm	3
32297	Ø 215 mm držalje 160 cm	3
32298	Ø 235 mm držalje 160 cm	3



MOTIKA ZA MALTER

Br.	Specifikacije	
60100	motika za malter 295 x 150 mm	24
61169	motika za malter sa drškom 160 cm	3
61218	Drška 160 cm	5

**FESTA**

ŠPAKLA ROST FREI

INOX

Br.	Specifikacije	
31497	63 x 195 mm	12

**FESTA**

NOZ ZA TAPETE

INOX

Br.	Specifikacije	
31503	150 mm	12



STRUGALICA ZIDARSKA

MADE IN EU

Br.	Specifikacije	
31501	100 mm	30
31502	Rezervni nož	1



ŠPAKLA ZA GIPSANE PLOČE

PLASTIC

Br.	Specifikacije	
34308	50 mm	20
34307	80 mm	12
34306	100 mm	10
34305	150 mm	12

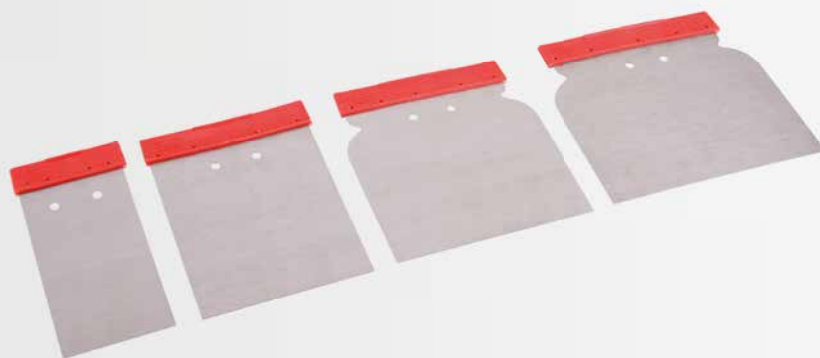
**FESTA**

ŠPAKLA JAPANKA

4x

Br.	Specifikacije	
31452	Rost frei 50, 80, 100, 120 mm	10
31453	Čelik 50, 80, 100, 120 mm	10

**FESTA**

ŠPAKLA JAPANKA

PLASTIC 4x

Br.	Specifikacije	
31454	50, 80, 100, 120 mm	12



ČELIČNA LOPATICA

Br.	Specifikacije	
31601	180 mm - Ravna	1
31602	180mm A1	1
31603	180mm A2	1
31641	180 mm - e4	1



ŠPAKLA INOX

Br.	Specifikacije	
31651	250 mm - Ravna	1
31655	250 mm - e4	1



GLADILICA PVC

Br.	Specifikacije	
37101	150 x 80 mm	100
37111	170 x 115 mm	100



GLADILICA PVC

Br.	Specifikacije	
37051	Ravna	1
37031	zub - 4 x 6 mm	1
37041	zub - 6 x 6 mm	1



MISTRIJA

Br.	Specifikacije	
32022	140 x 80 mm	12
32023	125 x 40 mm	12

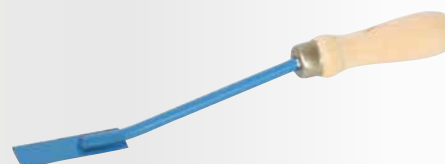

GLETARICA JEDNOSTRANA

Br.	Specifikacije	
32040	10 mm	20
32041	12 mm	20
32042	15 mm	20
32043	18 mm	20
32044	20 mm	20

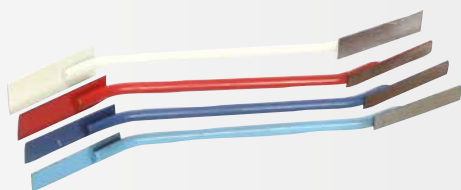

GLETARICA ZA FUGE DVOSTRANA

Br.	Specifikacije	
32050	10 12 mm	50
32051	10 15 mm	50
32052	10 18 mm	50
32053	15 20 mm	50



STRUGALICA ZA YTONG

Br.	Specifikacije	
32037	600 mm	1

**FESTA**

STRUGALICA DRVENA ZA YTONG

Topole

MOQ
2

Br.	Specifikacije
32317	450 x 95 mm



2

**FESTA**

STRUGALICA DRVENA ZA YTONG - FINI ZUB

Topole

MOQ
2

Br.	Specifikacije
32312	450 x 95 mm



2

**FESTA**

STRUGALICA DRVENA ZA YTONG

Topole

MOQ
2

Br.	Specifikacije
32337	260 x 95 mm



2

**FESTA**

STRUGALICA DRVENA ZA YTONG - FINI ZUB

Topole

MOQ
2

Br.	Specifikacije
32338	260 x 95 mm



2

**FESTA**

STRUGALICA ZA YTONG

Topole

MOQ
2

Br.	Specifikacije
32327	230 x 145 mm



2

NEW

STRUGALICA DRVENA ZA YTONG

MOQ
2

Br.	Specifikacije
32332	450 x 95 mm



2

NEW

STRUGALICA ZA YTONG

MOQ
2

Br.	Specifikacije
32333	230 x 145 mm



2



FESTA
STRUGALICA



Br.	Specifikacije
32314	400 x 180 mm



FESTA
STRUGALICA



Br.	Specifikacije
32329	270 x 130 mm



FESTA
STRUGALICA



Br.	Specifikacije
33168	380 x 160 mm

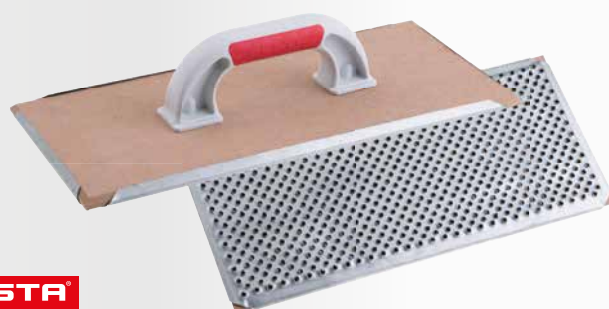

FESTA
STRUGALICA DRVENA



Br.	Specifikacije
32320	400 x 180 mm



NEW



FESTA
STRUGALICA



Br.	Specifikacije
32311	400 x 180 mm



FESTA
GLADILICA BRUSNA



Br.	Specifikacije
32418	400 x 180 mm P 16
32421	400 x 180 mm P 16 brus. papir



FESTA
GLADILICA BRUSNA



Br.	Specifikacije
32318	400 x 180 mm
32319	500 x 250 mm
32321	400 x 180 mm P 16 brus. papir
32322	500 x 250 mm P 16 brus. papir

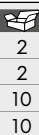

FESTA
PLASTIČNA BRUSNA GLETARICA



Br.	Specifikacije
32324	270 x 130 mm P 16
32323	270 x 130 mm P 16 brus. papir



**FESTA**

PLASTIČNA BRUSNA GLETARICA

MADE IN
EUMOQ
2

Br.	Specifikacije	
32330	400 x 180 mm	2
32331	270 x 130 mm	2

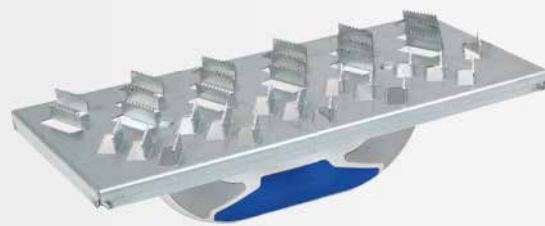

STRUGALO ZA KAMENU VUNU

Zn
MADE IN
EUMOQ
2

Br.	Specifikacije	
32328	285 x 145 mm	10

**FESTA**

GLETARICA SA CELICNIM TRAKAMA

MADE IN
EUMOQ
2

Br.	Specifikacije	
32325	225 x 105 mm	2

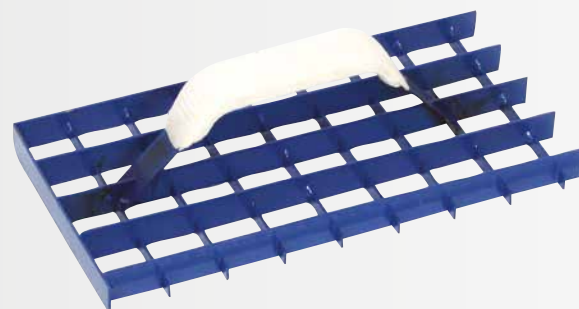

STRUGALICA MREŽASTA

MOQ
2

Br.	Specifikacije	
32316	280 x 150 mm	20

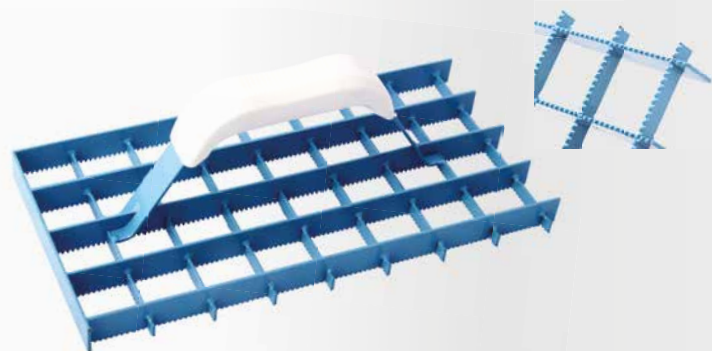

STRUGALICA MREŽASTA

MOQ
2

Br.	Specifikacije	
32335	290 x 145 mm	2



STRUGALICA ALU

· 8 nožići

ALU

MOQ
2

Br.	Specifikacije	
32326	450 x 90 mm	20



STRUGALICA ZA GIPS.PLOČE

· 6 nožići

MOQ
2

Br.	Specifikacije	
32315	270 x 90 mm	30

NEW



GLETARICA PLASTIČNA

MADE IN
EU

Br.	Specifikacije	
34028	400 x 180 mm	20



FESTA
GLETARICA PLASTIČNA



Br.	Specifikacije	
34027	400 x 180 mm	20



FESTA
GLETARICA PLASTIČNA



Br.	Specifikacije	
30003	270 x 125 mm	28
30004	235 x 115 mm	35
30005	210 x 115 mm	38
30007	210 x 60 mm	44



FESTA
GLETARICA DRVENA

· Lipovo drvo



Br.	Specifikacije	
34005	400 x 145 mm	40
34007	290 x 145 mm	20



FESTA
GLETARICA DRVENA

· topolovo drvo



Br.	Specifikacije	
34006	400 x 145 mm	40

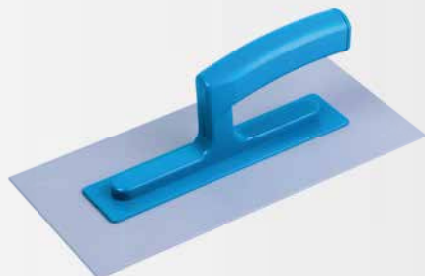

FESTA
GLETARICA PLASTIČNA ABS



Br.	Specifikacije	
34041	280 x 140 - 2 mm	10
34051	280 x 140 - 3 mm	10
34053	280 x 140 - 3 mm Nazubljen - e6	10



FESTA
LETVA ZA BETON



Br.	Specifikacije	
15889	980 x 380 mm Držalje Ø 32 mm	1



FESTA
SPAHLA SA GUMOM

Br.	Specifikacije	
15886	450 mm Držalje Ø 23 mm	48
15887	600 mm Držalje Ø 23 mm	48
15888	750 mm Držalje Ø 23 mm	32



FESTA
LETVA ZIDARSKA



Br.	Specifikacije	
15885	100 x 800 mm Držalje Ø 32 mm	1

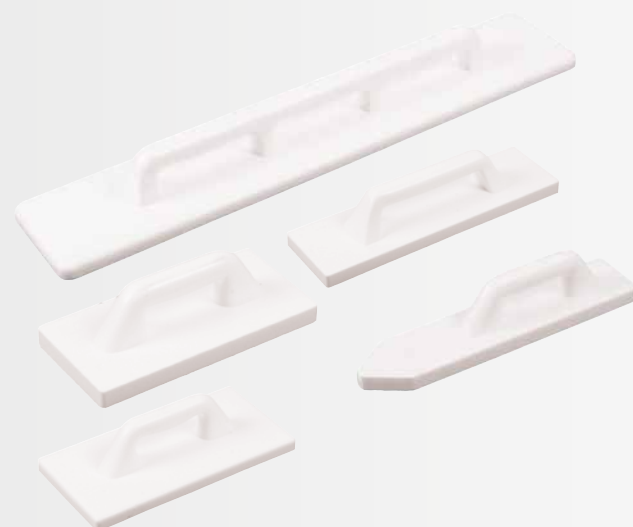

GLETARICA POLIURETANSKA



Br.	Specifikacije		Br.	Specifikacije	
34122	120 x 240 mm	50	34154	220 x 420 mm	15
34132	140 x 280 mm	40	34155	240 x 480 mm	15
34142	180 x 320 mm	25	34156	280 x 500 mm	10
34152	200 x 360 mm	20	34157	330 x 330 mm	5
34121	80 x 260 mm Zakošeno	50	34158	120 x 800 mm	5
34153	100 x 400 mm	30	34159	120 x 1000 mm	5
			34160	120 x 1200 mm	5

PERDAŠKA OD STIROPORA



Br.	Specifikacije	
34101	80 x 350 mm Zakošeno	10
34061	130 x 270 mm	10
34111	170 x 320 mm	10
34071	130 x 450 mm	10
34081	140 x 750 mm	10
34091	140 x 900 mm	5



GLETARICA POLIURETANSKA



Br.	Specifikacije	
34115	140 x 280 mm	36
34116	180 x 320 mm	36
34117	200 x 360 mm	24
34118	220 x 420 mm	24



DRŽAC BRUSNE SMIRGLE

Br.	Specifikacije	
34301	230 x 105 mm	1
34304	235 x 80 mm	1



FESTA

DRŽAČ BRUSNE MREŽICE

Br.	Specifikacije	
34200	210 x 115 mm	30
34201	240 x 105 mm	50
34202	240 x 80 mm	50



DRŽAČ BRUSNE MREŽICE

· Držalje 52030

ALU

Br.	Specifikacije	
34203	230 x 80 mm aluminium	1
52030	Štap teleskopski	12

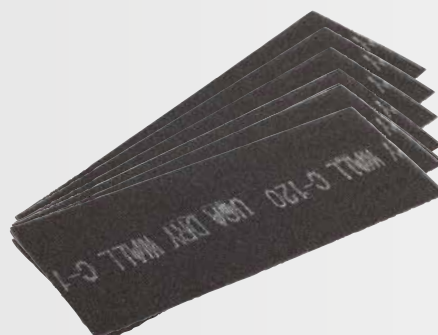

BRUSNA SMIRGLA

10x

Br.	Specifikacije	
34271	115 x 290 mm zrn. 120	80
34272	115 x 290 mm zrn. 100	80
34273	115 x 290 mm zrn. 80	80
34274	93 x 290 mm zrn. 120	80
34275	93 x 290 mm zrn. 100	80
34276	93 x 290 mm zrn. 80	80



BRUSNA SMIRGLA

3x

Br.	Specifikacije	
34280	115 x 290 mm zrn. 120	20
34281	115 x 290 mm zrn. 100	20
34282	115 x 290 mm zrn. 80	20
34283	93 x 290 mm zrn. 120	20
34284	93 x 290 mm zrn. 100	20
34285	93 x 290 mm zrn. 80	20

MATERIJAL PREDNJA STRANA	BETON		ŽBUKA/ FASADA			LJEPILA I MASE ZA FUGIRANJE	LJEPILO ZA FASADE	PRIMJENA
	GRUBO	POTĚROVÝ	TVRDA	MEKANA	MEKANA ZA YTONG			
CRNI FILC (SMEDI, SIVI)				••••		••		Za fino ravnanje fasade, koristi se za veće granulacije fasade.
BIJELI FILC				••••	••••	••••		Za fino ravnanje fasade, koristi se za manje granulacije fasade.
FINI MOLITAN				••••	••••	••••		Za eliminaciju pijeska na površini, za zaglađivanje finih materijala.
GRUBI MOLITAN				••••	••••	••••		Za eliminaciju pijeska na površini, za zaglađivanje grubih materijala.
RASTER MOLITAN				••••	••••	••••		Za eliminaciju pijeska, zahvaljujući rasteru pruža mogućnost boljeg zaglađivanja grubih materijala.
MORSKA SPUŽVA					•••		••••	Ispiranje spojnih materijala, za tanke spojeve (fuge), eliminacija pijeska u spoju.
HYDRO SPUŽVA FINA, GRUBA					•		••••	Ispiranje spojnih materijala, za debele spojeve (fuge), eliminacija pijeska u spoju.
SPUŽVA				••	••••	••	••••	Ispiranje spojnih materijala, zaglađivanje mekih fasada.
MIKROGUMA							••••	Za fugiranje
GUMENA PJENA							••••	Za fugiranje
MIRELON		••••	•••					Obrada betona, izvlačenje i fino ravnanje.
DUREN				••••	••	••••		Za ravnanje spojeva svježe fasade.
DRVO	••••	••••	••••					Obrada betona, izvlačenje i fino ravnanje.
ČELIČNI LIM	••	••••		••		••••	••	Zaglađivanje betona
STIROPOR	•••	••••	•••	••			••	Obrada betona, izvlačenje i fino ravnanje.
POLYURETHAN	••••	••••	••••					Obrada betona, izvlačenje i fino ravnanje.
ABS		••		••••	••••	••••	••••	Navlačenje sepa na fasadu, razvlačenje fine mekane fasade.
GLADILICA ROST FREI RAVNA				••••	••••	••••	••••	Razvlačenje fine mekane fasade, nanošenje ljepila za stiropor na fasadu.
GLADILICA ROST FREI NAZUBLJENA							••••	Nanošenje ljepila za elemente pročelja i podova.
STRUGALICA ZA STIROPOR PLASTIČNA			••				••••	Brušenje polistirena, cementnog ljepila, betona, fasade i gipsa.
STRUGALICA ZA STIROPOR DRVENA			••				••••	Brušenje fasadnog polistirena.

**FESTA**

GLETARICA SA BELIM FILCOM



Br.	Specifikacije		Br.	Specifikacije	
34400	280 x 140 x 8 mm	15	34450	220 x 130 x 8 mm	15
34415	250 x 130 x 8 mm	15	34445	220 x 70 x 8 mm	20

**FESTA**

GLETARICA PLASTIČNA SA CRNIM FILCOM



Br.	Specifikacije		Br.	Specifikacije	
34401	280 x 140 x 10 mm	15	34451	220 x 130 x 10 mm	15
34416	250 x 130 x 10 mm	15	34446	220 x 70 x 10 mm	20

**FESTA**

GLETARICA SA GRUBIM SUNĐEROM



Br.	Specifikacije	
34441	280 x 140 x 12 mm	15
34440	250 x 130 x 12 mm	15

**FESTA**

GLETARICA SA FINIM SUNĐEROM



Br.	Specifikacije		Br.	Specifikacije	
34405	280 x 140 x 18 mm	15	34480	280 x 140 x 12 mm	15
34420	250 x 130 x 18 mm	15	34481	250 x 130 x 12 mm	15
34454	220 x 130 x 18 mm	15	34482	220 x 130 x 12 mm	15
34449	220 x 70 x 18 mm	20			

**FESTA**

GLETARICA SA EKOMTRA FINIM SUNĐEROM



Br.	Specifikacije	
34443	280 x 140 x 12 mm	15
34442	250 x 130 x 12 mm	15
34439	250 x 130 x 18 mm	15

**FESTA**

GLETARICA SA FINIM MOLITANOM



Br.	Specifikacije		Br.	Specifikacije	
34404	280 x 140 x 30 mm	10	34419	250 x 130 x 20 mm	10
34485	280 x 130 x 20 mm	10	34453	220 x 130 x 20 mm	10
34486	250 x 130 x 30 mm	10	34447	220 x 70 x 20 mm	10

**FESTA**

GLETARICA SA REZ.MOLITANOM



Br.	Specifikacije	
34409	280 x 140 x 30 mm	10
34425	250 x 130 x 20 mm	10

**FESTA**

GLETARICA SA GRUBIM MOLITANOM



Br.	Specifikacije	
34410	280 x 140 x 30 mm	10
34426	250 x 130 x 20 mm	10



FESTA

GLETARICA SA MORSKIM SUNĐEROM



Br.	Specifikacije	
34406	280 x 140 x 30 mm	10
34421	250 x 130 x 30 mm	10
34455	220 x 130 x 30 mm	10



FESTA

GLETARICA SA REZ.MORSKIM SUNĐEROM



Br.	Specifikacije	
34413	280 x 140 x 30 mm	10
34428	250 x 130 x 30 mm	10



FESTA

GLETARICA SA HIDRO SUNĐEROM



Br.	Specifikacije	
34412	280 x 140 x 30 mm	10
34424	250 x 130 x 30 mm	10
34458	220 x 130 x 30 mm	10



FESTA

GLETARICA SA REZ.HIDRO SUNĐEROM



Br.	Specifikacije	
34490	280 x 140 x 30 mm	10
34491	250 x 130 x 30 mm	10



FESTA

GLETARICA SA FINIM HID.SUNĐEROM



Br.	Specifikacije	
34411	280 x 140 x 30 mm	10
34423	250 x 130 x 30 mm	10
34457	220 x 130 x 30 mm	10



FESTA

GLETARICA SA GUMENOM PENOM

Br.	Specifikacije	
34402	280 x 140 x 10 mm	15
34417	250 x 130 x 10 mm	15
34452	220 x 130 x 10 mm	15



FESTA

GLETARICA SA MIKRO GUMOM

Br.	Specifikacije	
34403	280 x 140 x 8 mm	15
34418	250 x 130 x 8 mm	15
34496	220 x 130 x 8 mm	15



FESTA

GLETARICA SA DURENOM



Br.	Specifikacije	
34407	280 x 140 x 20 mm	10
34422	250 x 130 x 20 mm	10
34456	220 x 130 x 20 mm	10
34448	220 x 70 x 20 mm	10

FESTA
GLETARICA SA RUVENOM



Br.	Specifikacije	
34414	280 x 140 x 20 mm	10
34429	250 x 130 x 20 mm	10
34459	220 x 130 x 20 mm	10
34479	220 x 70 x 20 mm	10

FESTA
GLETARICA PLASTIČNA

Br.	Specifikacije	
30003	270 x 125 mm	28
30004	235 x 115 mm	35
30005	210 x 115 mm	38
30007	210 x 60 mm	44

FESTA
GLETARICA ZA FUGOVANJE

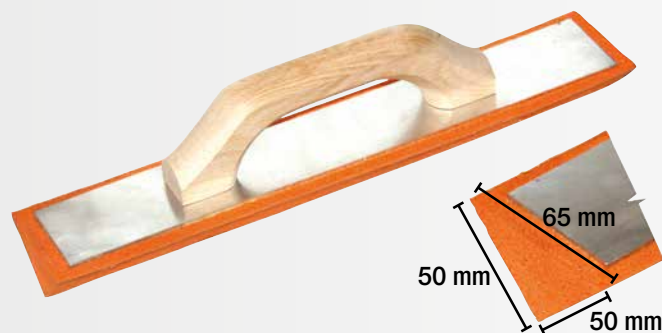
Br.	Specifikacije	
34033	240 x 95 mm	5

GLETARICA SA SUNĐEROM 90°

Br.	Specifikacije	
34500	350 mm	6

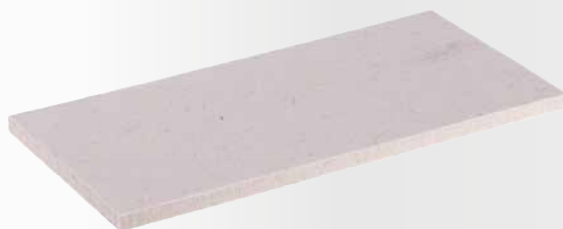
REZERVNI PLIŠ

Br.	Specifikacije	
34241	280 x 140 x 8 mm	1
34223	250 x 130 x 8 mm	1

REZERVNI FILC

Br.	Specifikacije	
34243	280 x 140 x 10 mm	1
34221	250 x 130 x 10 mm	1

REZERVNI SUNĐER

Br.	Specifikacije	
34262	280 x 140 x 18 mm	1

REZERVNI MOLITAN

Br.	Specifikacije	
34251	280 x 140 x 30 mm	1



REZERVNI MOLITAN



Br.	Specifikacije	
34261	280 x 140 x 30 mm	1

REZERVNI SUNĐER



Br.	Specifikacije	
34265	280 x 140 x 30 mm	1

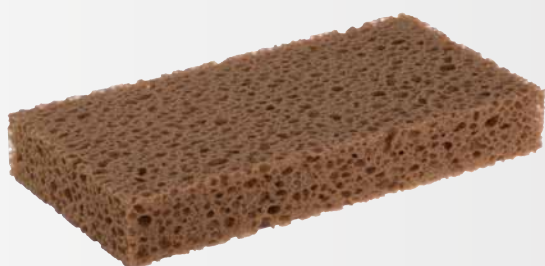

REZERVNI SUNĐER



Br.	Specifikacije	
34238	280 x 140 x 30 mm	1

REZERVNI SUNĐER



Br.	Specifikacije	
34237	280 x 140 x 30 mm	1
34235	250 x 130 x 30 mm	1



REZERVNA GUMA



Br.	Specifikacije	
34231	280 x 140 x 10 mm	1

FESTA**ELEKTRICKÉ MIECHADLO STAVEBNÝCH ZMESÍ DVOJMETĽOVÉ**

Napon	1800 W
Napon	230 V / 50 Hz
Stepeni brzina	2
1. stepen (brzina bez opterećenja)	0 - 450 ot./min.
2. stepen (brzina bez opterećenja)	0 - 790 ot./min.
Zaštita protiv preopterećen	Da
Prečnik bubnja mešalice	100 mm
Dužina mešača	570 mm
Težina	5,6 kg



Br.	Specifikacije	
35311	mešalica	1
35318	rezervni ugljenik	1
35319	rezervne mešalice - par (L+R)	1

**FESTA****MEŠALICA GRAĐEVINSKIH SMESA, 850W**

Ulazna snaga	850 W
Napon	230 V / 50 Hz
Stepeni brzina	1
1. stepen (brzina bez opterećenja)	0 - 500 ot./min
2. stepen (brzina bez opterećenja)	-
Zaštita protiv preopterećenja	Da
Navoj mešača mešalice	M 14
Prečnik bubnja mešalice	120 mm
Dužina mešača	600 mm
Težina	3,7 kg

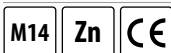

Br.	Specifikacije	
35300		1
35316	rezervni ugljenik	1

**FESTA****MEŠALICA GRAĐEVINSKIH SMESA, 1600W**

Ulazna snaga	1600 W
Napon	230 V / 50 Hz
Stepeni brzina	2
1. stepen (brzina bez opterećenja)	0 - 480 ot./min
2. stepen (brzina bez opterećenja)	0 - 800 ot./min.
Zaštita protiv preopterećen	Da
Navoj mešača mešalice	M 14
Prečnik bubnja mešalice	140 mm
Dužina mešača	600 mm
Težina	4,7 kg

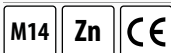

Br.	Specifikacije	
35310		1
35317	rezervni ugljenik	1



FESTA

MEŠAČ SPIRALNI

Spiralna mješalica sa tri oštrice i prstenom – desna – za žitke mase korištene u više slojeva. Miješani material je pritisnut. Retka masa ne prska iz posude, pigmenti u boji se ravnomjerno i dobro izmješaju.

Zn M14



Br.	Specifikacije	
35085	M14 Ø 120 x 600 mm	12
35086	M14 Ø 140 x 600 mm	12
35087	M14 Ø 160 x 600 mm	12

FESTA

MEŠAČ SPIRALNI

Spiralna mješalica sa tri oštrice i prstenom – lijeva – za teške materijale sa visokom viskoznošću (gustoćom), mortove, beton, cement i fasade, spojne materijale, epokomidne spojeve, bitumenska ljepila.

Zn M14



Br.	Specifikacije	
35091	M14 Ø 120 x 600 mm	12
35092	M14 Ø 140 x 600 mm	12
35093	M14 Ø 160 x 600 mm	12

FESTA

MEŠAČ SPIRALNI

Spiralna mješalica sa dvije oštrice – za potpuno miješanje ljepila za pločice, spojnih materijala, grubih materijala, estriha, završnih materijala i glatkih smjesa.

Zn



Br.	Specifikacije	
35038	Ø 80 x 500 mm	24
35058	Ø 100 x 500 mm	24
35023	Ø 120 x 500 mm	24

FESTA

MEŠAČ SPIRALNI

Spiralna mješalica sa dvije oštrice – za potpuno miješanje ljepila za pločice, spojnih materijala, grubih materijala, estriha, završnih materijala i glatkih smjesa.

SDS+ Zn



Br.	Specifikacije	
35094	Ø 80 x 500 mm	24
35095	Ø 100 x 500 mm	24
35096	Ø 120 x 500 mm	24

FESTA**MEŠAČ SPIRALNI**

Spiralna mješalica sa dvije oštrice - za potpuno miješanje ljepila za pločice, spojnih materijala, grubih materijala, estriha, završnih materijala i glatkih smjesa.

M14 **Zn**

Br.	Specifikacije
35059	M14 Ø 90 x 550 mm



24

FESTA**MEŠAČ SPIRALNI**

Spiralna mješalica sa dvije oštrice - za potpuno miješanje ljepila za pločice, spojnih materijala, grubih materijala, estriha, završnih materijala i glatkih smjesa.

 **Zn**

Br.	Specifikacije
35013	Ø 80 x 500 mm
35006	Ø 100 x 500 mm
35007	Ø 120 x 500 mm



24

24

24

FESTA**MEŠAČ SPIRALNI**

Spiralna mješalica sa dvije oštrice - za potpuno miješanje ljepila za pločice, spojnih materijala, grubih materijala, estriha, završnih materijala i glatkih smjesa.

SDS+ **Zn**

Br.	Specifikacije
35012	Ø 100 x 500 mm



24

FESTA**MEŠAČ SPIRALNI ŽIČANI**

Spiralna mješalica sa dvije oštrice - za potpuno miješanje ljepila za pločice, spojnih materijala, grubih materijala, estriha, završnih materijala i glatkih smjesa.

 **Zn**

Br.	Specifikacije
35069	Ø 60 x 500 mm
35078	Ø 80 x 500 mm
35081	Ø 100 x 500 mm



50

24

24

FESTA

MEŠAČ SPIRALNI ŽIČANI

Spiralna mješalica sa dvije oštrice - za potpuno miješanje ljepila za pločice, spojnih materijala, grubih materijala, estriha, završnih materijala i glatkih smjesa.

SDS+ Zn



Br.	Specifikacije	
35070	Ø 60 x 500 mm	50
35079	Ø 80 x 500 mm	24
35082	Ø 100 x 500 mm	24

FESTA

MEŠAČ SPIRALNI

Spiralna mješalica sa dvije oštrice - za potpuno miješanje ljepila za pločice, spojnih materijala, grubih materijala, estriha, završnih materijala i glatkih smjesa.

 Zn



Br.	Specifikacije	
35048	Ø 70 x 500 mm	24
35068	Ø 90 x 500 mm	24

FESTA

MEŠAČ SPIRALNI

Spiralna mješalica - za potpuno miješanje ljepila za pločice, spojnih materijala, grubih materijala, estriha, završnih materijala i glatkih smjesa.

 Zn



Br.	Specifikacije	
35021	Ø 100 x 500 mm	24

FESTA

MEŠAČ

Mješalica za potpuno miješanje ljepila za pločice, spojnih materijala, grubih materijala, estriha, završnih materijala i glatkih smjesa.

 Zn



Br.	Specifikacije	
35015	Ø 100 x 500 mm	20

FESTA**MEŠAČ MIKOMER**

Mješalica sa propelerom – za tekuće materijale, boje, ljepila za tapete, ljepila za pločice.



Br.	Specifikacije	
35011	Ø 80 x 500 mm	50

SPIRALNI MEŠAČ POCINKOVANI

Arkadna mješalica sa prstenom – za potpuno miješanje zidnih boja, disperzivnih boja, ljepila, ljepila za podove, boja, bitumenskih, asfaltnih i ostalih premaza.



Br.	Specifikacije	
35125	Ø 60 x 400 mm	40
35126	Ø 80 x 400 mm	40
35127	Ø 100 x 600 mm	20

MEŠAČ LAKIRANI

Arkadna mješalica sa prstenom – za potpuno miješanje zidnih boja, disperzivnih boja, ljepila, ljepila za podove, boja, bitumenskih, asfaltnih i ostalih premaza.



Br.	Specifikacije	
35103	Ø 60 x 400 mm	40
35113	Ø 80 x 400 mm	40
35123	Ø 100 x 600 mm	20

**PRODUŽNI KABEL NA MOTALICI**

- Extension cable with 25 m reel - IP20
- H05VV - F 3G 1,5mm², - Equipped with a thermal fuse
- H05VV - F 3G 1,5mm²
- Welding power: 1000 W max.
- Output power: 3000 W max.
- 4 grounded sockets with child lock.



Br.	Specifikacije	
37760	4 socket, dužina 25 m, IP 20, 1,5 mm ²	2
37761	4 socket, dužina 50 m, IP 20, 1,5 mm ²	2

PRODUŽNI KABEL

Br.	Specifikacije	
37730	max. 3680 W dužina 10 m, 1,5 mm ²	8
37731	max. 3680 W dužina 20 m, 1,5 mm ²	4

ELEKTRIČNI GREJAČ 3,3KW

Napon	230V ~50 Hz
Snaga	3300 W
Current load	14.5 A
Set up performance	30/1650/3300 W
Temperaturni opseg	5-40°C
Zaštita	IP24
Mere	27 x 25.5 x 40 cm
Težina	4.8 kg

- fast and efficient heating of cellars, workhops, shops, party tents, greenhouses etc. |
- does not consume oxygen
- safe operation, continuous power control, room thermostat, fan
- stainless steel heating element
- possibility of summer use for ventilation without heating
- low noise
- high-quality processing, materials, robust steel construction, easy and safe handling, long service life



Br.	Specifikacije
35833	3,3 kW



1



GREJAČ NA PLIN 15KW

Plin	G30-i3B/P
Pritisak	0.7 bar
Napon	230 V 50 Hz
Engine output	25 W
Potrošnja plina	1.11 kg/h
Max snaga	15 kW
Protok vazduha	300 m ³ /h

- fast and efficient heating during construction work, workhops
- it consumes oxygen
- safe operation, smooth power regulation
- thermostat and safety valve against overheating and leakage
- accessories included - controller and inlet gas hose
- high-quality processing, materials, robust steel construction, easy and safe handling with a long service life



Br.	Specifikacije
35845	15 kW



1



GREJAČ NA PLIN 30KW

Plin	g30-i3b/p
Pritisak	1.5 bar
Napon	230 V 50 Hz
Engine output	70 W
Potrošnja plina	2.2 kg/h
Max snaga	30 kW
Protok vazduha	750 m ³ /h

- fast and efficient heating during construction work, workhops
- it consumes oxygen!
- direct air heating with forced circulation - rapid heat gain
- safe operation, smooth power regulation
- thermostat and safety valve against overheating and leakage
- accessories included - controller and inlet gas hose
- high-quality processing, materials, robust steel construction, easy and safe handling with a long service life



Br.	Specifikacije
35850	30 kW



1





Mešalice za zahtevnu profesionalnu upotrebu
Pogonski venac napravljen od čvrstog čelika sa patentiranim učvršćivačem.

Podesivi zubi.

Vrhunska završna obrada.

Dvostruki ležaj na bubnju mešalice.

Specijalno dizajniran oblik bubnja.

Zaštita protiv prskanja. IP 45.

Obezbedjuje se u 230v I 400v.

PROFESIONALNE MEŠALICE ZA BETON

Lescha

Lescha
MEŠALICA



Br.	Specifikacije	
35500	Star 150 - 125 l, 230 V nožni odmor	1



Lescha
MEŠALICA



Br.	Specifikacije	
35502	EUROMIX 125 l, 230 V	1
35503	EUROMIX 125 l, 400 V	1



Lescha
MEŠALICA



Br.	Specifikacije	
35501	BX 135 - 125 l, 230 V	1



Lescha
MEŠALICA



Br.	Specifikacije	
35504	ABM 135 l, 230 V nožni odmor	1



Lescha
MEŠALICA



Br.	Specifikacije	
35505	SM 145 S - 140 l, 230 V	1
35506	SM 145 S - 140 l, 400 V	1
35507	SM 145 S - 140 l, 230 V nožni odmor	1
35508	SM 145 S - 140 l, 400 V nožni odmor	1



Lescha
MEŠALICA



Br.	Specifikacije	
35510	SM 165 S - 160 l, 230 V nožni odmor	1
35511	SM 165 S - 160 l, 400 V nožni odmor	1
35512	SM 165 S - 160 l, G benzinska	1





Lescha
MEŠALICA
MADE IN EU

Br.	Specifikacije	
35514	SM 185 S - 180 l, 230 V nožni odmor	1
35515	SM 185 S - 180 l, 400 V nožni odmor	1



Lescha
MEŠALICA
MADE IN EU

Br.	Specifikacije	
35516	S 180 HR - 180 l, 230 V nožni odmor	1
35517	S 180 HR - 180 l, 400 V nožni odmor	1



Lescha
MEŠALICA
MADE IN EU

Br.	Specifikacije		
35524	LB 354 230 V, 1,5 kW		1
35525	LB 354 400 V, 1,5 kW		1
35527	LB 354 Honda G200		1
35532	LB 404 230 V, 1,5 kW		1
35533	LB 404 400 V, 1,5 kW		1
35539	LB 484 Robin EH17B		1
35540	LB 484 Honda GX160LX		1
35542	AT 480 400 V, 1,2 kW		1



Lescha
MEŠALICA
MADE IN EU

Br.	Specifikacije		
35552	LHB 1000 400 V		1
35553	LHB 1000 HATZ Diesel		1
35555	LHB 1200 400 V		1



Lescha
MEŠALICA
MADE IN EU

Br.	Specifikacije	
35518	S 230 HR - 230 l, 230 V nožni odmor	1
35519	S 230 HR - 230 l, 400 V nožni odmor	1

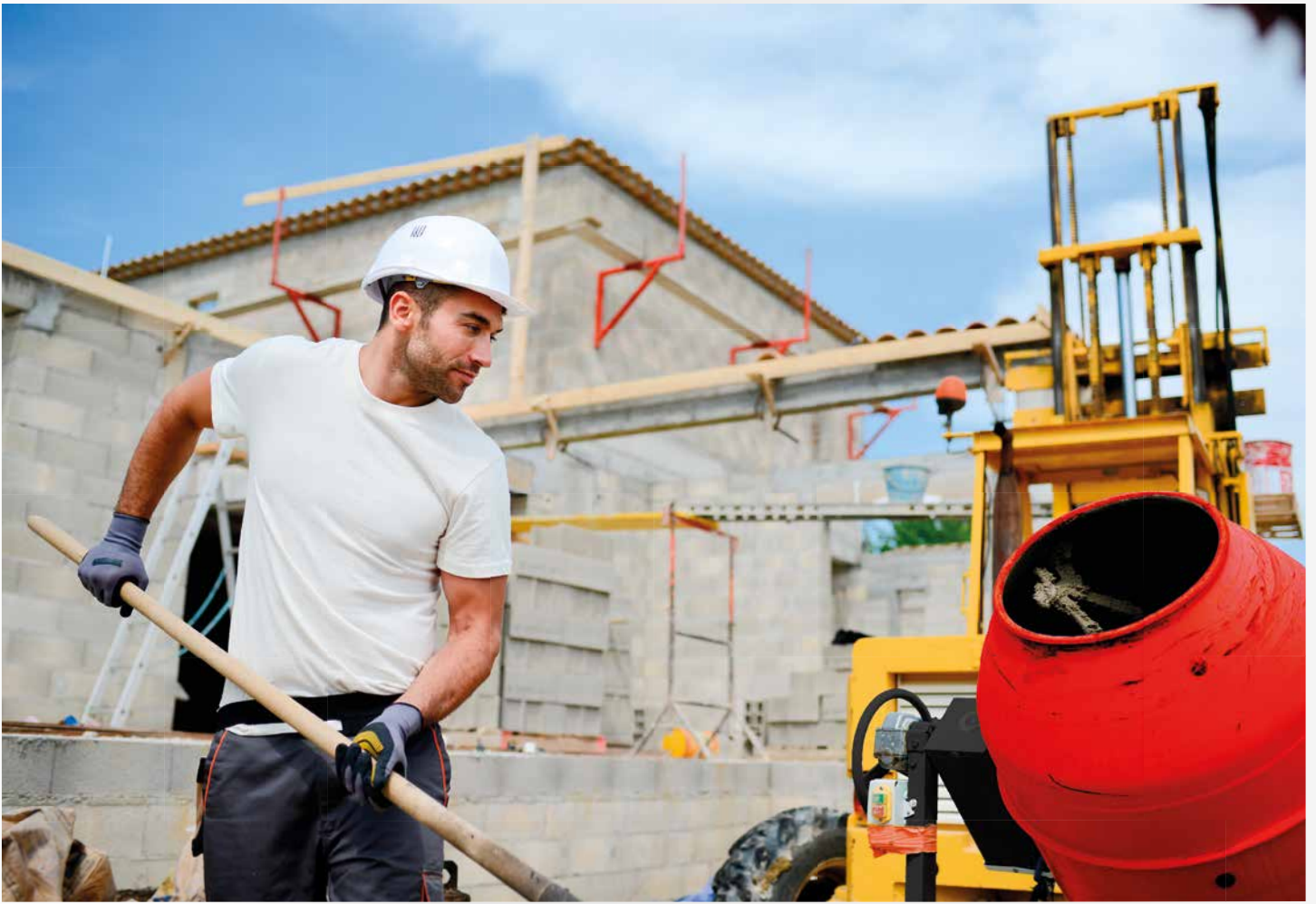

130 L

Specifikacije

volume of drum	130 l
drum speed	26±Min ⁻¹
power	700 W
voltage	230 V / 50 Hz
degree of protection	IP44
material of chaplet	Litinový
dimensions	Dužina 1170 mm
	Širina 650 mm
	Visina 1280 mm
weight	53 kg

165 L

Specifikacije

volume of drum	165 l
drum speed	23±Min ⁻¹
power	900 W
voltage	230 V / 50 Hz
degree of protection	IP44
material of chaplet	Litinový
dimensions	Dužina 1295 mm
	Širina 735 mm
	Visina 1440 mm
weight	70 kg



MEŠALICA



Br.	Specifikacije				
37500	MIX 130Zk	230 V	unassembled		1
37501	MIX 130Z	230 V	assembled		1
37505	MK 165Bk	230 V	unassembled		1
37506	MK 165B	230 V	assembled		1

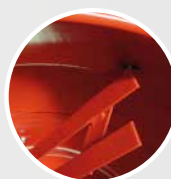

• specially made shoulder-blade 4 mm



• good quality thrust bearing



• switch with safety shield



• plastic shield of drive, cast iron wreath

MEŠALICA



125 L

Specifikacije	
volume of drum	125 l
drum speed	26±Min ⁻¹
power	550 W
voltage	230 V / 50 Hz
degree of protection	IP44
material of chaplet	Litínový
dimensions	Dužina 1102 mm Širina 690 mm Visina 1310 mm
weight	52,5 kg

Br.	Specifikacije		
37509	126 l, 230 V	assembled	1
37510	126 l, 230 V	unassembled	1

162 L

Specifikacije	
volume of drum	162 l
drum speed	26±Min ⁻¹
power	650 W
voltage	230 V / 50 Hz
degree of protection	IP44
material of chaplet	Litínový
dimensions	Dužina 1180 mm Širina 710 mm Visina 1310 mm
weight	56 kg

Br.	Specifikacije		
37515	162 l, 230 V	unassembled	1
37516	162 l, 230 V	assembled	1

142 L

Specifikacije	
volume of drum	142 l
drum speed	26±Min ⁻¹
power	650 W
voltage	230 V / 50 Hz
degree of protection	IP44
material of chaplet	Litínový
dimensions	Dužina 1164 mm Širina 690 mm Visina 1293 mm
weight	54 kg

Br.	Specifikacije		
37511	142 l, 230 V	unassembled	1
37512	142 l, 230 V	assembled	1

180 L

Specifikacije	
volume of drum	180 l
drum speed	26±Min ⁻¹
power	850 W
voltage	230 V / 50 Hz
degree of protection	IP44
material of chaplet	Litínový
dimensions	Dužina 1164 mm Širina 690 mm Visina 1368 mm
weight	58 kg

Br.	Specifikacije		
37517	180 l, 230 V	unassembled	1
37518	180 l, 230 V	assembled	1

**Lescha**

PUNILAC GRADJEVINSKIM OTPADOM



Br.	Specifikacije	
35603	zhoz základný priemer 50/40 cm, dĺžka 108 cm PE (HDPE)	1
35604	násypka zhodu stavebnej sutiny PE (HDPE)	1
35605	nosný rám pre násypku zhodu stavebnej sutiny	1



GRAĐEVINSKA KOLICA - TAČKE



Br.	Specifikacije	
37530	60 l, Ø 38 cm Točak bez naduvavanja	1
37532	60 l, Ø 40 cm Točak za naduvavanje	1



GRAĐEVINSKA POCINKOVANA KOLICA - TAČKE



Br.	Specifikacije	
37527	80 l, Ø 40 cm Točak za naduvavanje	1
37533	80 l, Ø 38 cm Točak bez naduvavanja	1



REZERVNO KORITO ZA KOLICA



Br.	Specifikacije	
37539	60 l	1



REZERVNO KORITO POCINKOVANO



Br.	Specifikacije	
37541	80 l	1



REZERVNI TOČKOVI ZA KOLICA



Br.	Specifikacije		
48729	typ AA 400	Točak za naduvavanje	1
48730	typ AA 380	Točak bez naduvavanja	1
48731	typ AA 380	Točak bez naduvavanja	1



GRAĐEVINSKA KOLICA - TAČKE SA TRI TOČKA



Br.	Specifikacije	
37564	60 l	1



DRŽAČ ZA CIGLE

Br.	Specifikacije	
36310	max. 20kg	5



DRŽAČ IVIČNJAKA

Specifikacije	60115
Dimenzija ivičnjaka	80-370 mm
Max.	50 kg



Br.	Specifikacije	
60115	PRO 040	1

DRŽAČ IVIČNJAKA

Specifikacije	60116
Dimenzija ivičnjaka	750-1000 mm
Max.	120 kg



Br.	Specifikacije	
60116	PRO 041	1



ČEKIĆ

Specifikacije	60121	60123
Višina	200 mm	200 mm
Širina	70 kg	70 kg
Dužina	870 mm	450 mm
Težina	2,5 kg	2,2 kg



Br.	Specifikacije	
60121	870 mm	1
60123	450 mm	1

DRŽAČ IVIČNJAKA

Specifikacije	60117	60118
Dimenzija ivičnjaka	500-1000 mm	0-500 mm
Max.	150 kg	150 kg



Br.	Specifikacije	
60117	PRO 042	1
60118	PRO 043	1



PODMETAČ



Br.	Specifikacije	
37166	D10 osnovni	25

NEW



FESTA

PODESEVI NASLON

· max.: 590 kg

Br. Specifikacije

23657



1

NEW



FESTA

PRENOSIVI ŠKRIPAC

· domet: 0 - 95 cm

· max.: 250 kg

Br. Specifikacije

37553



1



RUČNA KOLICA ZA PRENOŠENJE TERETA

Br.	Specifikacije	nosnost	
48719	kolo 260 mm bantam	250 kg	1

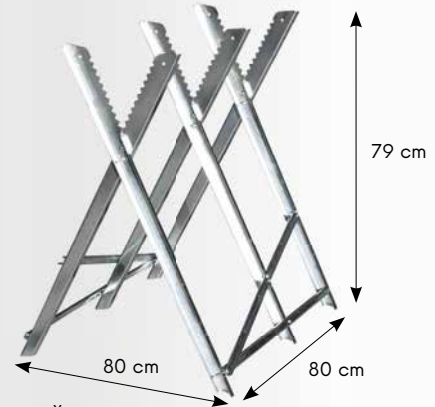

KOZA ZA SEČU DRVA

Br.	rozměry	
37570	max. 150 kg	1

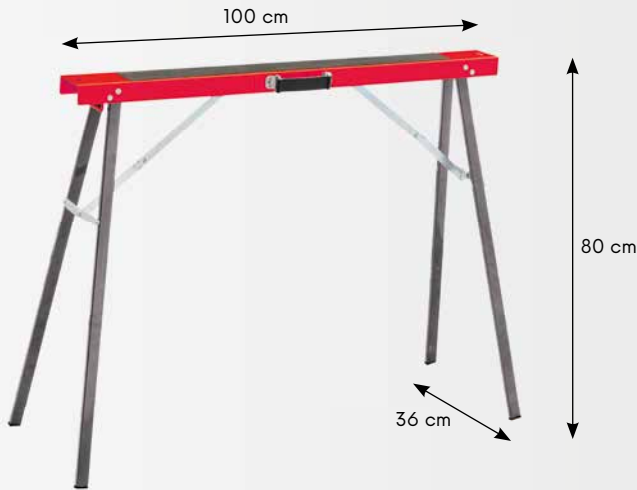

PODESEVI NASLON

max. 125 kg

2x

Br.	Specifikacije	
37549	pár	1



PODESEVI NASLON - PLASTIČNI

Max. 150 kg (300 kg u paru)

2x

Br.	Specifikacije	
37560	pár	1

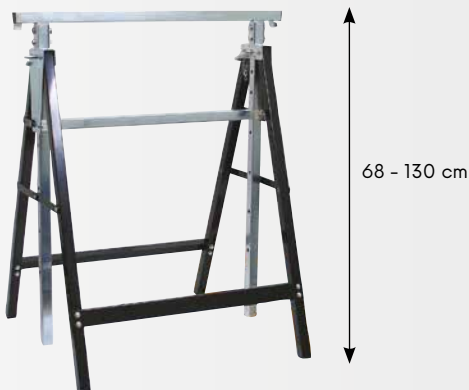

PODESEVI NASLON

Br.	Specifikacije	
36300	68 - 130 cm, max. 125 kg	1



PODESEVI NASLON

Br.	Specifikacije	
37545	140 cm, Visina 98 - 165 cm	1
37546	120 cm, Visina 98 - 165 cm	1

PROFESIONALNI REZAČI PLOČICA

- Rezač pločica za najzahtevnije PROFIL korištenje
- Klizanje je rešeno sa devet kugličnih ležajeva SKF, a četiri se daju podešavati
- Amortizirajući stol
- Rezač se može postaviti za rad sa lijevom rukom
- Osigurani rezervni dijelovi i servis
- Rezni točkići od hrom-wolfram čelika

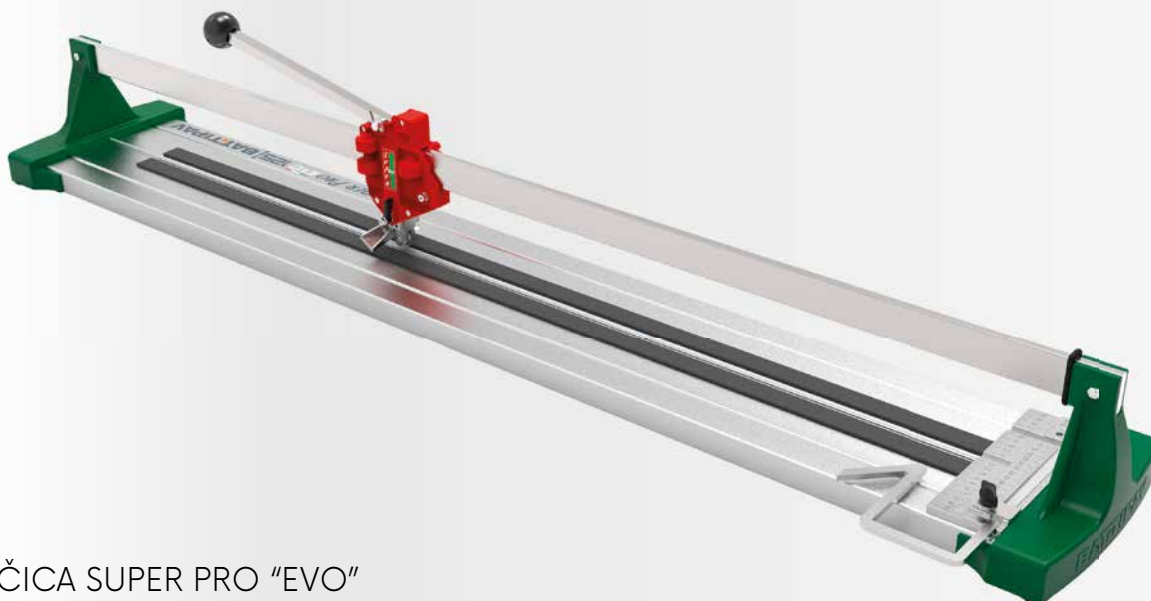

SUPER PRO



REZAČ PLOČICA SUPER PRO "EVO"

- 36195 Rezerni rezni točkić - Ø 22 mm



Br.	Specifikacije
36191	1250 mm



1

SUPER PRO



REZAČ PLOČICA SUPER PRO

- 36195 Rezerni rezni točkić - Ø 22 mm



Br.	Specifikacije
36145	SUPER PRO 450 mm
36160	SUPER PRO 600 mm
36175	SUPER PRO 750 mm
36190	SUPER PRO 900 mm



1

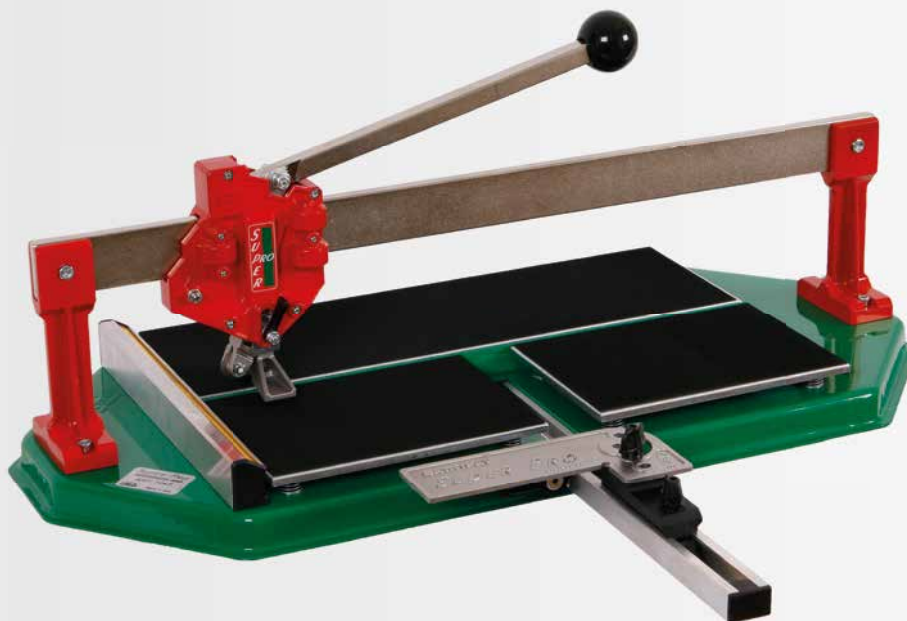



REZAČ PLOČICA BASIC PLUS + KUFR

· 36261 Rezervni rezni točkić - Ø 15 mm



Br.	Specifikacije	
36240	400 mm	1



· ilustracija fotografija

POLICA REKLAMNA SUPER PRO



Br.	Specifikacije	
36200	Stalak	1
36199	Stalak za 36160, 36175, 36190	1



FESTA

REZAČ PLOČICA „X“

· 36138 Rezervni rezni točkić - Ø 22 mm



Br.	Specifikacije	
36085	600 mm	1
36087	900 mm	1
36086	1300 mm	1



FESTA

REZAČ PLOČICA

· 36195 Rezervni rezni točkić - Ø 22 mm



Br.	Specifikacije	
36080	600 mm	1
36081	750 mm	1
36082	900 mm	1
Br.	Specifikacije	
36076	750 mm assembled	1
36077	900 mm assembled	1

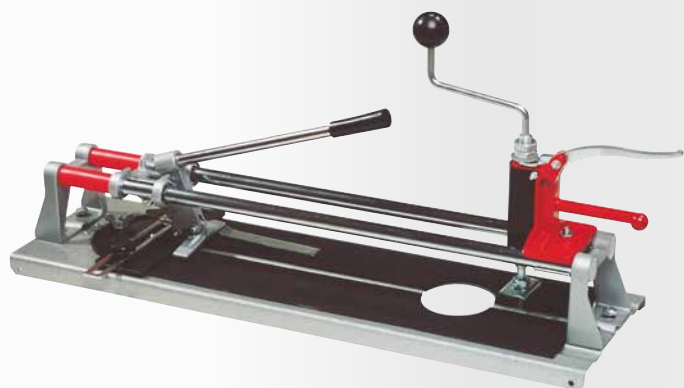

REZAČ PLOČICA

• 36128 Rezervni rezni točkić - Ø 16 mm



Br.	Specifikacije
36014	480 mm



4

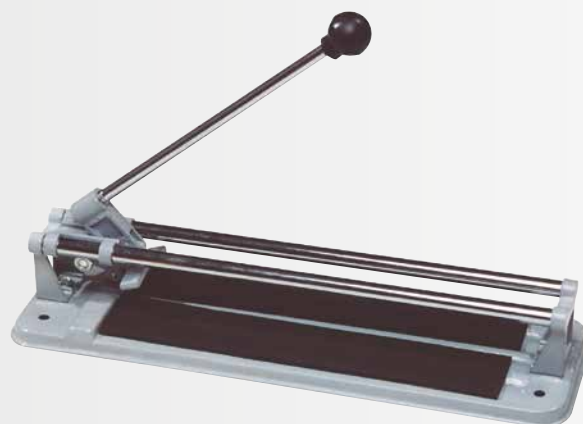

REZAČ PLOČICA

• 36126 Rezervni rezni točkić - Ø 15 mm



Br.	Specifikacije	
36024	300 mm	10
36034	400 mm	10
36035	600 mm	4



10

10

4



REZAČ PLOČICA

• 36136 Rezervni rezni točkić - Ø 22 mm



Br.	Specifikacije
36036	480 mm



1



REZAČ PLOČICA RUČNI

• 36136 Rezervni rezni točkić - Ø 22,2 mm



Br.	Specifikacije	
36046	22 mm	1



1



REZERVNI TOČKIĆ ZA REZAČ PLOČICA



Br.	Specifikacije	
36126	a= Ø 15 mm, b= Ø 6 mm, c= 1,5 mm	1
36128	a= Ø 16 mm, b= Ø 6 mm, c= 3 mm	1
36130	a= Ø 20 mm, b= Ø 6 mm, c= 5 mm	1
36136	a= Ø 22 mm, b= Ø 6 mm, c= 2 mm	1



TESTERA ZA PLOČICE

Br.	Specifikacije	
24055	Karbid - BOSCH, MAKITA	1



FESTA

KLEŠTA ZA PLOČICE

Br.	Specifikacije	
36057	200 mm	6



KLJEŠTA ZA PLOČICE

Br.	Specifikacije	
36056		10



KLJEŠTA ZA PLOČICE

Br.	Specifikacije	
36059		1



KLJEŠTA ZA PLOČICE PAPAGAJ

Br.	Specifikacije	
36058	200 mm	6



37028



37029



37025



37026

SUNĐER MEKI KOCKASTI 160 X 110 X 60 MM

Br.	Specifikacije	
37028	hidro sunđer	1
37029	Morski sunđer	1



SUNĐER MEKI KOCKASTI 200 X 100 X 100 MM

Br.	Specifikacije	
37025	Fina	1
37026	Morski sunđer	1



**KANTA ZA PRANJE
PAHUKA**

Br.	Specifikacije	
37117	Komplet	1
90070	Kanta 25 l	1

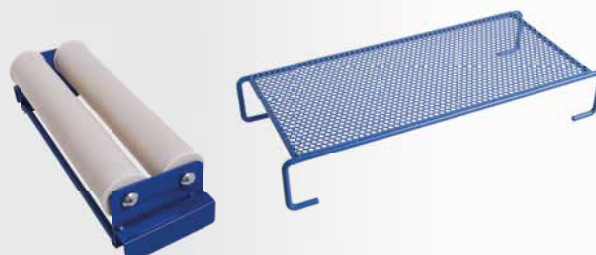

KANTA ZA PRANJE - PRIBOR

Br.	Specifikacije	
90072	Rešetka	1
90071	Metalni valjci	1





4 mm

UGAONI ČISTAČ



Br.	Specifikacije
37012	

1



UGAONI ČISTAČ



Br.	Specifikacije	
37006	30 mm	20
37007	50 mm	20
37008	Rezervni nož 30 mm	50
37009	Rezervni nož 50 mm	50



SET ČISTAČA ZA SILIKON

3x



Br.	Specifikacije
16042	

12

**FESTA**

GLADILICA ZA SILIKON



Br.	Specifikacije
16056	145 mm

50



GLADILICA ZA SILIKON

4x



Br.	Specifikacije
37053	

48



GLADILICA ZA SILIKON

Br.	Specifikacije
37054	

1



GLADILICA ZA SILIKON

· Za brtvljenje prozora

Br.	Specifikacije
37055	

1



GLADILICA DRVENA SA GUMOM

Br.	Specifikacije	
37011	180 mm	12
37021	280 mm	12

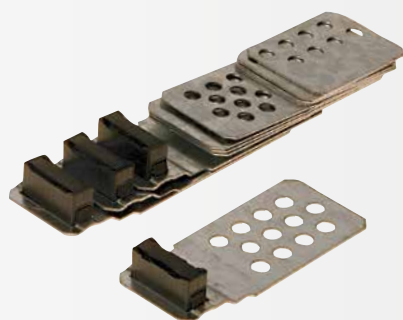

MAGNET ZA VRATANCA



Br.	38920	1
-----	-------	---



MAGNET POMIČNI ZA VRATANCA



Br.	38923	24
-----	-------	----

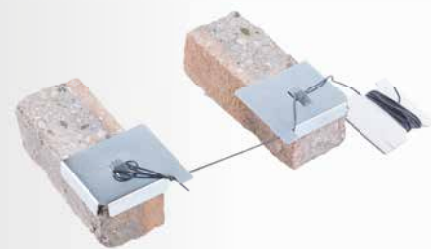

UGAONI GRADJEVINSKI



Br.	38919	50
-----	-------	----



SEKAČ ZA LAMINAT I VINIL



Br.	36140	Specifikacije	210 mm	4
-----	-------	---------------	--------	---



KOMPLET ZA POSTAVLJANJE LAMINATA



Br.	52130	1
-----	-------	---



KLIN



Br.	Specifikacije	Kom.	1
37210	95 x 45 x 15 - 0 mm	50	1
37211	70 x 30 x 8 - 0 mm	50	1



VAZDUŠNI JASTUK ZA MONTAŽU

- Dimenzija
- MaKom. visina

Br.	37220	1
-----	-------	---

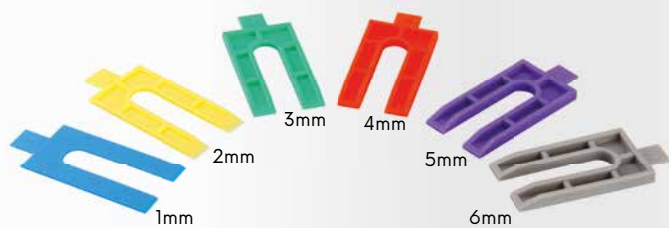

ODSTOJNICI

30x

Br.	Specifikacije	Kom.
37212	1 - 6 mm, 5x bilo koje veličine	1



FESTA

KLIN



Br.	Specifikacije	Kom.
37204	55 x 20 x 0 - 6 mm	20
37203	65 x 18 x 0 - 12 mm	20
37202	80 x 25 x 3 - 10 mm	20
37201	100 x 25 x 1 - 16 mm	14
37200	150 x 25 x 1 - 25 mm	8
37205	55 x 8 x 0 - 10 mm	250

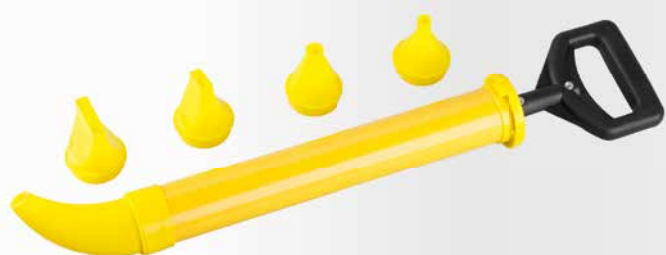

PIŠTOLJ ZA INJEKTIRANJE



Br.	Specifikacije	Kom.
38026	5x vrh	1



KESA ZA FUGOVANJE



Br.	Specifikacije	Kom.
38042	3x vrh	1



NIVELYS KRSTIĆI ZA PLOČICE

100x

Br.	Specifikacije	Kom.
37195	1,0 mm	100
37196	1,5 mm	100
37197	2 mm	100
37198	3 mm	100



FESTA

KRSTIĆI ZA PLOČICE



Br.	Specifikacije	Kom.		Br.	Specifikacije	Kom.	
37148	1,0 mm	200	100	37152	3 mm	150	100
37149	1,5 mm	200	100	37153	4 mm	100	100
37150	2 mm	200	100	37154	5 mm	75	100
37151	2,5 mm	200	100	37158	10 mm	30	100



FESTA

KAJLICE ZA PLOČICE PVC



Br.	Specifikacije	Kom.
37155	0 - 8 mm	30
37156	0 - 4 mm	100
37157	2,5 - 8 mm	30



FESTA

KAJLICE ZA PLOČICE PVC

250x



Br.	Specifikacije	Kom.
37205	55 x 8 x 0 - 10 mm	250

NEW



NIVELAČNÍ KLIP SADA

50x

Br.	Specifikacije Specification
37199	1,5 mm



40



NIVELYS
NAVOJNI ODSTOJNI KLIP

50x

Br.	Specifikacije
37131	1 mm
37132	2 mm



40

NIVELYS
ŠEŠIR ZA IZRAVNAVANJE SA KONCEM

50x

Br.	Specifikacije
37130	



15



NIVELYS
LEVELING SYSTEM **FESTA**

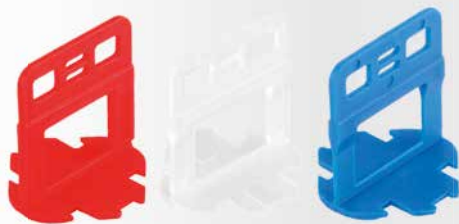

NIVELYS SPONE – DISTANCERI

· kajle za nivelaciju 37175, 37176

50x



Br.	Specifikacije	Kom	
37170	1 mm	50	60
37171	2 mm	50	60
37172	3 mm	50	60



NIVELYS SPONE – DISTANCERI

100x



Br.	Specifikacije	Kom	
37185	1 mm	100	1
37190	1,5 mm	100	1
37186	2 mm	100	1

Br.	Specifikacije	Kom	
37187	3 mm	100	1
37188	4 mm	100	1
37189	5 mm	100	1

NEW

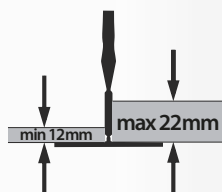

NIVELYS SPONE – DISTANCERI

100x



Br.	Specifikacije	Kom	
37162	1,5 mm	1	



NIVELYS KAJLE ZA NIVELACIJU

Br.	Kom	
37175	50	40
37176	400	3



NIVELYS SPONE – DISTANCERI

600x



Br.	Specifikacije	Kom	krabice	
37125	1 mm	600	38 x 28 x 19 cm	1
37126	1,5 mm	600	38 x 28 x 19 cm	1
37127	2 mm	600	38 x 28 x 19 cm	1



NIVELYS
LEVELING SYSTEM **FESTA**

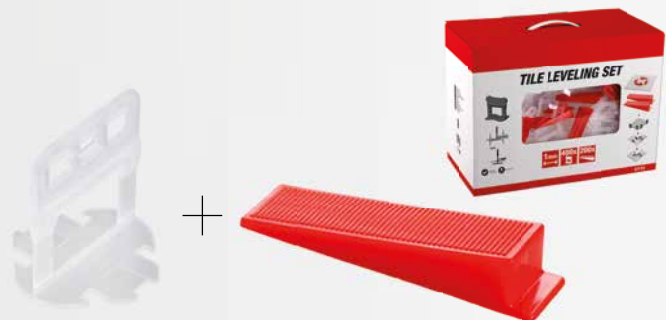

NIVELYS SPONE – DISTANCERI + KAJLE ZA NIVELACIJU

Br.	Specifikacije	
37173	1 mm, 400 Kom + 200 Kom	1
37174	1,5 mm, 400 Kom + 200 Kom	1



NIVELYS
KLEŠTA ZA NIVELACIJU

Br.
37177



NIVELYS
KLEŠTA ZA NIVELACIJU

Br.
37178



NEW



FESTA
DRŽAČ PLOČICA
SA INDIKATOROM VAKUUMA
grube i strukturirane površine

Br. 36325 Specifikacije max. 220 kg



FESTA

PUDER ZA OCRTAVANJE 180 G

Br.	Specifikacije	
37096	Plavi	10
37094	Svetlo plavi	10
37097	Crveni	10
37095	Svetlo crveni	10
37098	Crn	10

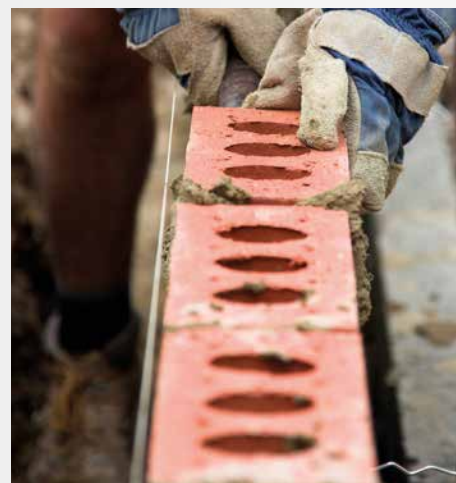
**FESTA**

NOSAČ ZID. KANAPA 30 M SA PUDEROM 120 G

- 6x brži mehanizam za namotavanje
- Funkcija visak

Br.
37070

6

**FESTA**

NOSAČ ZID.KANAPA 30 M + PUDEROM 150 G

- 5x brži mehanizam za namotavanje

Br.
37065

6



NOSAČ ZID. KANAPA ABS 30 SA PUDEROM 180 G

Br.
37069

10



NOSAČ ZID.KANAPA ABS

Br.
37067

25



NOSAČ ZID.KANAPA 30M

Br.
37066

25



NOSAČ ZID.KANAPA 30M

Br.
37068

25



FESTA

KANAP ZIDARSKI - CRVENI



Br.	Specifikacije	
38895	50 m	24
38896	100 m	24

FESTA

KANAP ZIDARSKI - ŽUTI



Br.	Specifikacije	
38899	50 m	24
38900	100 m	24



FESTA

KANAP ZIDARSKI POLYETYLEN 50 M



Br.	Specifikacije	
38907	Crveni 1,0 mm	100
38908	Crveni 1,7 mm	100
38909	Crveni 2,0 mm	100

FESTA

KANAP ZIDARSKI POLYETYLEN 50 M



Br.	Specifikacije	
38904	Žuti 1,0 mm	100
38905	Žuti 1,7 mm	100
38906	Žuti 2,0 mm	100



FESTA

KANAP ZIDARSKI POLYETYLEN 50 M



Br.	Specifikacije	
38910	Narandžasti 1,0 mm	100
38911	Narandžasti 1,7 mm	100
38912	Narandžasti 2,0 mm	100

FESTA

KANAP ZIDARSKI POLYETYLEN 50 M



Br.	Specifikacije	
38901	Beli 1,0 mm	100
38902	Beli 1,7 mm	100
38903	Beli 2,0 mm	100

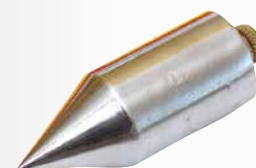

KANAP



Br.	Dužina	Ø	
50920	50 m	1 mm	80

FESTA

VISAK SA KANAPOM 15 M



Br.	Specifikacije	
38916	150 g	10
38917	300 g	6
38918	500 g	5

FESTA

VISAK



Br.	Specifikacije	
38913	150 g	10
38914	300 g	10
38915	500 g	10

NEW



FESTA

REZAČ STIROPORA

- Voltaža 230 V/50 Hz
- Potrošnja struje 160 W
- Dužina reza 137 cm
- Visina reza 30 cm
- Zaštita IP44
- Ugao rezanja 0° - 90°

· oprema: postolje, nožni prekidač, držač za skele, 2k Ni-Cr žica za sečenje, mesingana četka za čišćenje, alati i pričvršćivači, plastična kutija sa točkovima



Br. Specifikacije

35348



1

NEW



FESTA

NOŽNI PREKIDAČ
ZA REZAČ POLISTIRENA

za 35330, 35345, 35348



Br. Specifikacije

35334

1

NEW



FESTA

STAJATI
ZA REZAČ POLISTIRENA

za 35330, 35345, 35348



Br. Specifikacije

35336

1

NEW



FESTA

ZAMENA OPRUGE
ZA REZAČ POLISTIRENA

za 35330, 35345, 35348



Br. Specifikacije

35332

1

NEW



FESTA

DRŽAČ ZA SKELE
ZA REZAČ POLISTIRENA

za 35330, 35345, 35348



Br. Specifikacije

35333

1

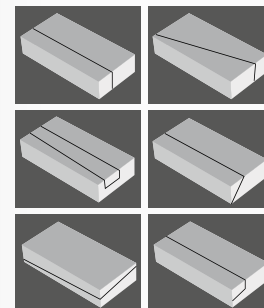
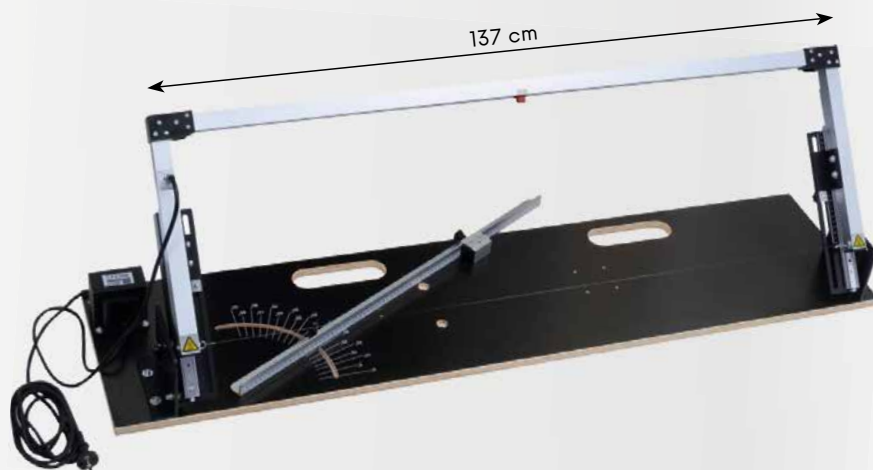

FESTA

REZAČ STIROPORA

- Voltaža **230 V / 50 Hz**
- Potrošnja struje **160 W**
- Dužina reza **137 cm**
- Visina reza **30 cm**
- Zaštita **IP44**
- Ugao rezanja **0° - 90°**



· Oprema: Ni-Cr žica za sečenje, čišćenje četke od mesinga, imbus



Br.	Specifikacije	
35345	Rezač stiropora 1500 x 450 mm	1
35346	Rezervna žica za sečenje Ni-Cr	1
35347	Rezervno napajanje	1

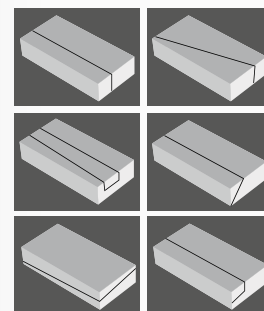
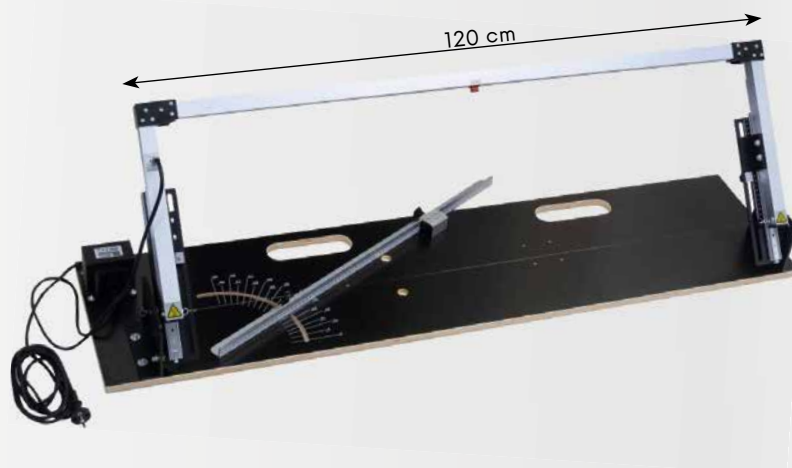

FESTA

REZAČ STIROPORA

- Voltaža **230 V / 50 Hz**
- Potrošnja struje **160 W**
- Dužina reza **120 cm**
- Visina reza **30 cm**
- Zaštita **IP44**
- Ugao rezanja **0° - 90°**



· Oprema: Ni-Cr žica za sečenje, čišćenje četke od mesinga, imbus



Br.	Specifikacije	
35330	Rezač stiropora 1350 x 450 mm	1
35331	Rezervna žica za sečenje Ni-Cr	1
35347	Rezervno napajanje	1

**FESTA****REZAČ ZA POLISTIRENSKE, BATERIJE**

- baterija 36 V, 1,5 Ah Li-ion
- potrošnja struje 180 W
- temperature max 350 C°
- dužina rezu 20 cm



· oprema: 2 baterije, punjač, sečivo, mesing četka za čišćenje, šesterokut

Br. Specifikacije

35323



1

**FESTA****ELEKTRIČNI REZAČ STIROPORA**

- Voltaža 230 V / 50 Hz
- Potrošnja struje 250 W
- Temperature 50-600 C°
- Dužina rezu 25 cm
- Dužina kabla za napajanje 3 m



· Oprema: čišćenje četke od mesinga, inbus, nož 25 cm

Br.	Specifikacije	
35326	Električni rezač stiropora	1
35328	Rezervni nož za rezač stiropora 14 cm	1
35329	Rezervni nož za rezač stiropora 25 cm	1

**VODJICA ZA REZANJE STIROPORA**

· 35323, 35326

Br.	Specifikacije	
35327	Vodjica za rezanje polistirena	1
35335	Rezervni nož - 30 cm	1

FESTA**ELEKTRIČNI REZAČ STIROPORA**

· Regulacija temperature

Br. Specifikacije

35325 220 W



1



NEW



FESTA
GLODALICA
ZA STIROPOR

ALU

Br.	Specifikacije	
24752	Ø 65 mm	1
24753	Ø 70 mm	1

NEW



TIPLA U IZOLACIJU ZA
ČAURE ZA OLOVNE ZAVRTNJE

2x

Br.	Specifikacije	
39240	beo M10	1
39241	siva M10	1
39242	antracit M10	1
39243	Brown M10	1
39244	crn M10	1

GLODALICA ZA STIROPOR

Br.	Specifikacije	
24727	Ø 65 mm	1
24729	Ø 68 mm	1
24728	Ø 70 mm	1



TIPLI ZA FASAD

100x

MADE IN EU

Br.	Specifikacije		Br.	Specifikacije	
39210	Ø 10 x 100 mm	1	39218	Ø 10 x 180 mm	1
39212	Ø 10 x 120 mm	1	39217	Ø 10 x 200 mm	1
39214	Ø 10 x 140 mm	1	39219	Ø 10 x 220 mm	1
39216	Ø 10 x 160 mm	1			

NEW



TIPLI ZA STIROPOR

za zavrtnje Ø 6 i 8 mm

50x

Br.	Specifikacije	
39208	Ø 68 mm	1

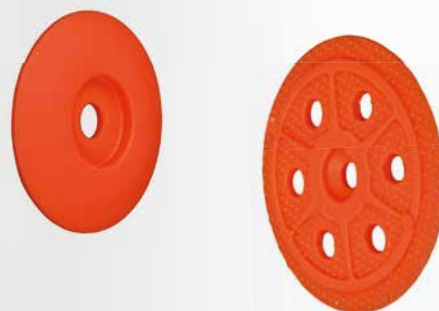

TIPLI ZA STIROPOR

Br.	Specifikacije	
39206	Ø 40 mm	200
39207	Ø 60 mm	100



PLASTICNI UGAO



Br.	Specifikacije	
39238	3 m	25



PAPIRNATI UGAO SA DVIJE ALU TRAKE



Br.	Specifikacije	
39245	AL 30 m x 5 cm	1



TIPLI ZA RABICO



Br.	Specifikacije	
42420	Ø 30 mm	1



PLETIVO RABICO



Br.	Specifikacije	
42312	1 m 50 bm 16 x 16 mm	1



VALJAK



Br.	Prečnika	Visina vrha	Dužina	
38950	Ø 69 mm	12 mm	25 cm	10
38951	Ø 69 mm	12 mm	40 cm	8
38952	Ø 122 mm	34 mm	25 mm	10
38953	Ø 122 mm	34 mm	40 cm	8
38954	Ø 122 mm	34 mm	60 mm	4

PEDALE SA ŠILJCIMA



Br.	Specifikacije	
38970	šiljci 25 mm	1
38971	šiljci 30 mm	1





KOMPLET ZA POSTAVLJANJE GIPSANIH PLOČA

Br.	Specifikacije	
34300	9 Kom	10
34303	Kanta	60



POSTOLJE ZA POSTAVKU GIPS PLOČA

- 153 - 344 cm
- max. 54 kg

Br.	Specifikacije	
26775		1



FESTA

NOSAČ PLOČA

2x

Br.	Specifikacije	
36312		12



FESTA

NOSAČ PLOČA

Br.	Specifikacije	
36308	36 x 16,5 x 7,5 cm	10

NEW



VALJAK ZA NANOŠENJE GLET MASE

- drška 180 mm - 52630
- drška 250 mm - 52625
- Držači 52010, 52011, 52012, 52020, 52030



Br.	Specifikacije	
52611	250 mm	50
52612	180 mm	10





FASADERSKA MAŠINA

Zn



1

Br.
37114

FASADERSKA MAŠINA

Zn

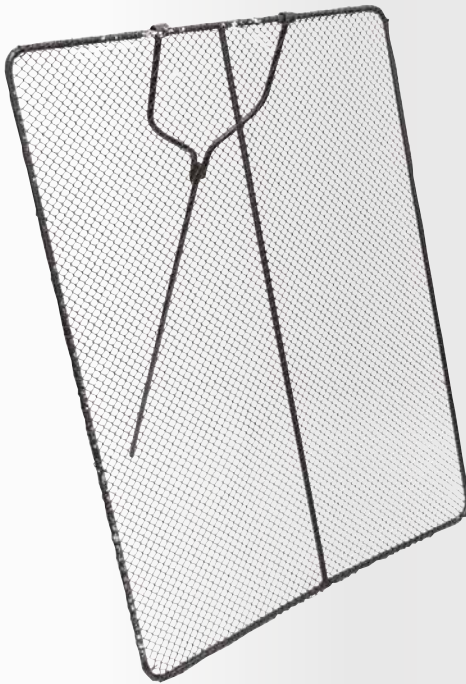

1

Br. Specifikacije
37115

SITO U RAMU

Br.	Širina	Visina	Oko sito	
37236	0,8 m	1 m	10 mm	1
37237	0,8 m	1 m	12 mm	1
37238	0,8 m	1 m	16 mm	1
37239	0,8 m	1 m	20 mm	1



SITO ZA PESAK



Br.	Širina	Visina	Oko sito	
37216	50 mm	50 mm	2 mm	1
37217	50 mm	50 mm	3 mm	1
37218	50 mm	50 mm	4 mm	1



DRVENI KOŠULJICA



Br.	Dužina	Debljina	Širina	
37120	200 mm	1,7 mm	20 mm	10
37119	250 mm	1,7 mm	20 mm	10

MOQ
10

10



MREŽA ZAŠTITNA ZELENA

Br.	Specifikacije		
42120	2,5 x 20 m, 80 g/ m ²	zelena	5



SMESA ZA POBOLJŠANJE BETONA

- +/- 150 g/ 50 kg cementu
- 600 - 900 g/m² beton ili malter



Br.	váha		
42115	0,9 kg		9

REVIZIONA VRATANCA MAGNETIC



Br.	Specifikacije		
82105	25 x 25 cmzidarstvo		1



KAJLA ZA FIKOMIRANJE



Br.	Specifikacije		
37229	14,5 cm		10



KAJLA ZA FIKOMIRANJE POC.



Br.	Specifikacije		
37231	14 cm labavo		10



KAJLA ZA FIKOMIRANJE KOVANA



Br.	Specifikacije		
37232	14,5 cm		5



KAJLA ZA FIKOMIRANJE



Br.	Specifikacije		
37230	16 cm		6



STEGA-KLANFA



Br.	Specifikacije		
37233	320 x 10 mm		100
37234	320 x 12 mm		100



STEGA-KLANFA



Br.	Specifikacije		
37235	250 x 12 mm		1



BRENER
KRAČIY

FESTA

BRENER KRAČI

Ø 17, 22, 40 mm



Br. Specifikacije

69918 2 kW, 1,5 m crijeva



10

FESTA

BRENER KRAČI

Ø 25, 35, 50 mm



Br. Specifikacije

69919 19,5 kW, 1,5 m crijeva



10

FESTA

BRENER KRAČI

Ø 55 mm



PIEZO
START



Br. Specifikacije

69904 60 kW, 850 mm, 5 m crijeva



8



FESTA

BRENER KRAČI SA CREVOM 3 KW



AK 601423580004

Br. 69914

Specifikacije 300 mm + 2 m crijeva



5



FESTA

BRENER KRAČI 300 MM



AK 601423580004

Br. 69900

Specifikacije Ø 35 mm, Dužina 300 mm, bez crijeva



10

69901

Ø 35 mm, Dužina 300 mm + 3 m crijeva

5



FESTA

BRENER KRAČI



AK 601423580004

Br. 69902

Specifikacije Ø 55 mm, Dužina 550 mm, bez crijeva



10



FESTA

BRENER KRAČI



AK 601423580004

Br. 69903

Specifikacije Ø 55 mm, Dužina 550 mm + 3 m crijeva



10



FESTA

BRENER KRAČI



AK 601423580004

Br. 69905

Specifikacije Ø 55 mm, Dužina 850 mm, bez crijeva



10



FESTA

BRENER KRAČI



AK 601423580004

Br. 69906

Specifikacije Ø 55 mm, Dužina 850 mm + 3 m crijeva



5

**FESTA****BRENER KRAČI 850 MM**

· Regulator za priključenje 10 a 33 kg bombi



Br.	Specifikacije
69917	Ø 60 mm, Dužina 900 mm + 3 m crijeva 3 m



1

FESTA**CREVO ZA BRENER KRAČI**

Br.	Specifikacije
69910	3 m sa završetkom
69911	5 m sa završetkom
69912	10 m sa završetkom



20

12

8

**FESTA****PLINSKI BRENER NA NAVOJNOM ULOŠKU**

· maKom. temperatura 1200 °C
 · energija 1,7 kW
 · prečnik brener Ø 20 mm



Br.	Specifikacije
69930	piezo

20

**FESTA****PLINSKI BRENER NA PIERCING KERTRIDŽU**

· maKom. temperatura 1200 °C
 · energija 1,7 kW
 · prečnik brener Ø 20 mm



Br.	Specifikacije
69931	piezo

12



REDUCIRANI VENTIL PROPAN - BUTAN



Br. 69923
Specifikacije W 21,8; G 3/8; 4 bar

1



REDUCIRANI VENTIL

Izlazni pritisak	4,0 bar
Nominalni protok	16 kg h
inlet connection	W 21,8 x 1 14" LH
outlet connection	G3 8" LH



Br. 69920
Specifikacije

25



REDUCIRANI VENTIL PROPAN - BUTAN

Ulazni pritisak	25 bar
Izlazni pritisak	0,5 - 4,0 bar
Nominalni protok	16 kg h
inlet connection	W 21,8 x 1 14" LH
outlet connection	G3 8" LH



Br. 69907
Specifikacije

1



JEDNOSMERNI VENTIL PRITISKA

- Izlazni spoj G 3/8L, za bočicu od 2 kg
- G 3/8L, za 2 kg



Br. 69928
Specifikacije

1



REGULATOR PRITISKA



Br. 69908
Specifikacije 30 mBar, trn

Br. 69909
Specifikacije 30 mBar, závit G 1/4L

1

1



ČINIJA ZA GIPS

Br.	Specifikacije	
37121	Konusna	1



ČINIJA ZA GIPS

Br.	Specifikacije	
37122	Niska	1



ČINIJA ZA GIPS



Br.	Specifikacije	
33275	Niska, guma	20



POCINKOVANA KOFA

Zn

Br.	Specifikacije	
39000	5 l	40
39001	10 l	30
39002	12 l	20
39003	15 l	20



KANTA ZIDARSKA



Br.	Specifikacije	
39005	5 l	1
39010	10 l	1
39012	12 l	1
39014	15 l Sa naljevom	1
39020	20 l	1
39021	20 l Sa naljevom	1



KORITO



Br.	Specifikacije	
39192	30 l	20
39193	45 l	20



KANTA ZIDARSKA OKRUGLA



Br.	Specifikacije	
39045	45 l Ø 54 x 27 cm	1
39065	60 l Ø 60 x 35 cm	1
39090	90 l Ø 66 x 35 cm	1



KANTA ZIDARSKA CET.



Br.	Specifikacije	
39145	45 l 71 x 40 x 21 cm	1
39165	65 l 71 x 40 x 30 cm	1
39190	85 l 77 x 48 x 30 cm	1

KOTURAČA ZA POD.TERETA SA KUKOM



Br.	Specifikacije	
26780	0,5 t A with hook	1
26781	0,5 t B with eye	1
26782	0,5 t C with hook, with cover	1
26783	0,5 t D with eye, with cover	1





FOLIJA



Br.	Širina	Dužina	Debljina		Kom
38095	500 mm	600 m	8 µm	Transparentno	1
38097	100 mm	150 m	20 µm	Transparentno	1
38096	500 mm	200 m	23 µm	Crn	1



PVC VRECA ZA
GRADJEVINSKI OTPAD



Br.	Širina	Dužina	Debljina	kapacitet	Kom
39194	500 mm	1100 mm	0,16 mm	100 l	1
39196	600 mm	1200 mm	0,16 mm	110 l	1
39198	700 mm	1100 mm	0,16 mm	120 l	1
39200	500 mm	1100 mm	0,20 mm	100 l	1
39202	600 mm	1200 mm	0,20 mm	110 l	1
39204	700 mm	1100 mm	0,20 mm	120 l	1



PVC VRECA ZA
GRADJEVINSKI OTPAD



Br.	Širina	Dužina	Debljina	kapacitet	Kom
39195	500 mm	1100 mm	0,16 mm	100 l	1
39197	600 mm	1200 mm	0,16 mm	110 l	1
39199	700 mm	1100 mm	0,16 mm	120 l	1
39201	500 mm	1100 mm	0,20 mm	100 l	1
39203	600 mm	1200 mm	0,20 mm	110 l	1
39205	700 mm	1100 mm	0,20 mm	120 l	1



KESA ZA DJUBRE



Br.	Širina	Dužina	Debljina	Kom
38060	700 mm	1100 mm	0,08 mm	10
38063	700 mm	1100 mm	0,10 mm	3
38065	700 mm	1100 mm	0,20 mm	3



KESA ZA DJUBRE



Br.	Širina	Dužina	Debljina	Kom
38050	500 mm	600 mm	0,04 mm	25
38052	600 mm	800 mm	0,04 mm	25
38054	700 mm	1100 mm	0,04 mm	25

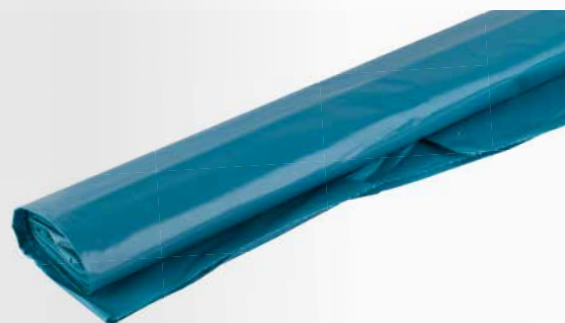

KESA ZA DJUBRE



Br.	Širina	Dužina	Debljina	Kom
38055	1200 mm	1000 mm	0,08 mm	5



VEZICA



Br.	Specifikacije	Kom
42365	1,25 100 mm	1
42366	1,25 125 mm	1
42367	1,25 140 mm	1
42368	1,25 160 mm	1



ALAT ZA VEZIVANJE

Br.	Specifikacije	Kom
50052		12
50050		1



ALAT ZA VEZIVANJE

Br.	Specifikacije	Kom
50051		2



UPOZORAVAJUĆA TRAKA - DALEKOVOD

Br.	Širina	Dužina	
38955	22 cm	20 m	1
38956	22 cm	50 m	1



UPOZORAVAJUĆA TRAKA - VODA

Br.	Širina	Dužina	
38957	22 cm	20 m	1
38958	22 cm	50 m	1



UPOZORAVAJUĆA TRAKA - GASNI

Br.	Širina	Dužina	
38959	22 cm	20 m	1
38960	22 cm	50 m	1



UPOZORAVAJUĆA TRAKA

Br.	Specifikacije	Dužina	
38944	ZÁKAZ VSTUPU, SK	80 mm 250 m	8
38945	VSTUP ZAKÁZÁN, CZ	80 mm 250 m	8



UPOZORAVAJUĆA TRAKA

Br.	Dužina	
38948	80 mm 250 m	8



UPOZORAVAJUĆA TRAKA

Br.	Dužina	
38946	80 mm 250 m	8



UPOZORAVAJUĆA TRAKA - SAMOLJEPIVA

Br.	Dužina	Specifikacije	
38947	48 mm 33 m	jel tako	48
38961	48 mm 33 m	levo	48



MARKIRNA TRAKA

Br.	Širina	Dužina	Debljina	
38949	50 mm	50 m	0,15 mm	36

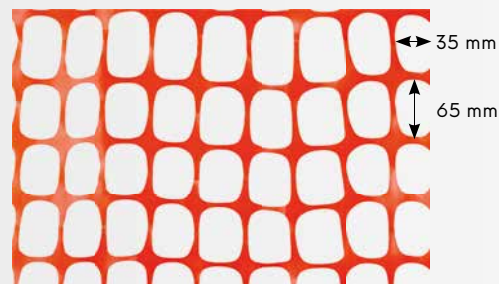

SIGURNOSNA OGRADA



Br.	Specifikacije	
42190	1,2 x 50 m HDPE 140g/m ²	1



TRAKA PVC

5x

Br.	Širina	Dužina	Debljina	
38931	19 mm	5 m	0,13 mm	100



TRAKA PVC, CRNA

Br.	Širina	Dužina	Debljina	
38932	19 mm	10 m	0,13 mm	10



TRAKA PVC

Br.	Širina	Dužina	Debljina	
38925	19 mm	10 m	0,13 mm	10



TRAKA PVC, CRNA

Br.	Širina	Dužina	Debljina	
38968	19 mm	10 m	0,19 mm	10



POJAČANA TRAKA CRNA

Br.	Širina	Dužina	
38927	19 mm	10 m	10



TRAKA TEKOTIL ZA TEPIH

Br.	Širina	Dužina	
38980	48 mm	10 m	24
38981	48 mm	20 m	24





OBOSTRANO LJEPLJIVA TRAKA

Br.	Širina	Dužina	
38924	50 mm	10 m	1
38964	50 mm	25 m	1



OBOSTRANO LJEPLJIVA TRAKA-PROZIRNA

				
Br.	Širina	Dužina		
38929	50 mm	10 m	1	
38966	50 mm	25 m	1	



OBOSTRANO LJEPLJIVA TRAKA-PROZIRNA

				
Br.	Širina	Dužina		
38990	19 mm	5 m	48	
38991	25 mm	5 m	36	



PROFESIONALNA DUCT TAPE TRAKA



Br.	Širina	Dužina	
38995	48 mm	25 m	24



ALU-TEKOMTIL TRAKA

Br.	Širina	Dužina	
38965	30 mm	10 m	1
38928	50 mm	10 m	72
38934	50 mm	45 m	24



PROFESIONALNA DUCT TAPE TRAKA



Br.	Širina	Dužina	
37275	48 mm	50 m	24



ZAŠTITNA TRAKA ZA FASADU I GIPS



Br.	Širina	Dužina	
37271	38 mm	20 m	24
37270	48 mm	20 m	24
37272	48 mm	50 m	24



ZAŠTITNA TRAKA ZA PROZORE

Za 30 dana



Br.	Širina	Dužina	
37273	48 mm	50 m	24



PAPIRNA MASKIRNA TRAKA PROFI



Br.	Širina	Dužina	
37263	38 mm	50 m	24
37264	48 mm	50 m	24



PVC LJEPLJIVA TRAKA



Br.	Širina	Dužina	
37266	30 mm	33 m	60
37267	38 mm	33 m	48
37268	50 mm	33 m	36



KREP TRAKA



Br.	Širina	Dužina	
37255	19 mm	50 m	12
37256	25 mm	50 m	12
37257	30 mm	50 m	7
37258	38 mm	50 m	6
37259	50 mm	50 m	6



TRAKA PVC



Br.	Širina	Dužina	
38942	50 mm	50 m	72





OBLOŽENA KAIŠEVIMA



Br.	Širina	Dužina	
38972	50 mm	50 m	1
38973	50 mm	100 m	1



ALU-SAMOLJEPIVA TRAKA



Br.	Širina	Dužina	
38963	48 mm	10 m	1
38943	48 mm	45 m	24



TRAKA PROTIV KLIZANJA

Br.	Širina	Dužina	Debljina	
37280	25 mm	15 m	0,8 mm	72
37281	50 mm	15m	0,8 mm	36



TRAKA SAMOVULKANIZIRAJUCA

Br.	Širina	Dužina	
38930	19 mm	5 m	100



TRAKA SAMOLEPLJIVA (FIBERGLASS)



Br.	Širina	Dužina	
38935	50 mm	20 m	60
38937	50 mm	45 m	36
38939	50 mm	90 m	24
38940	50 mm	153 m	24



FILC STAKLENI



Br.	Širina	Dužina	
38941	50 mm	25 m	40



TRAKA TEFLON



Br.	Širina	Dužina	Debljina	
38969	19 mm	15 m	0,2 mm	10



TRAKA TEFLON



Br.	Širina	Dužina	Debljina	
38933	12 mm	10 m	0,075 mm	10



TEFLON KONAC

· Za vodovodne i gasne instalacije



Br.	Širina	Dužina	
38926	2 mm	150 m	20



VELKRO TRAKA 3 KOM



Br.	Širina	Dužina	
37295	20 mm	150 mm	1
37296	20 mm	200 mm	1
37297	20 mm	250 mm	1



DISPENZERI ZA PAKETNU TRAKU

Br.	
38985	1



VELKRO TRAKA



Br.	Specifikacije	
45471	12 mm x 5 m	1

NEW



Prekidač za korak unazad
sa 3 položaja



• 360° rotirajuća glava

• drška otporna na udarce
najlon + fiberglas



• promena doze
9:1 / 18:1



FESTA

PIŠTOLJ ZA SILIKON SA POVRATNIM KORAKOM

Br. I No. Specifikacije | Specification

38027



1

NEW



povratni korak prekidač

FESTA

PIŠTOLJ ZA SILIKON SA POVRATNIM KORAKOM

Br. I No. Specifikacije | Specification

38028



1



FESTA

PIŠTOLJ ZA SILIKON KOBRA

Br.	Specifikacije	
38013		12



FESTA

PIŠTOLJ ZA SILIKON KOBRA

Br.	Specifikacije	
38001		24



FESTA

PIŠTOLJ ZA SILIKON KOBRA

Br.	Specifikacije	
38012		6



FESTA

PIŠTOLJ ZA SILIKON KOBRA

Br.	Specifikacije	
38025		1



PIŠTOLJ ZA SILIKON SA POVRATNIM KORAKOM

Br.	Specifikacije	
38010	Šestougaona	24



PIŠTOLJ ZA SILIKON KOBRA

Br.	Specifikacije	
38025		24



FESTA

PIŠTOLJ ZA SILIKON (HEMIC) 380 ML

Br.	Specifikacije	
38020		12



PIŠTOLJ ZA SILIKON SCORPION

Br.	Specifikacije	
38006		12



PIŠTOLJ ZA SILIKON

Br.	Specifikacije	
38002	6ti hran	24



PIŠTOLJ ZA SILIKON PLASTIČNI

Br.	Specifikacije	
38003	6ti hran	24



PIŠTOLJ ZA SILIKON (HROM)

Br.	Specifikacije	
38007		24



PIŠTOLJ ZA SILIKON POLUZATVORENI PVC

Br.	Specifikacije	
38008		24



PIŠTOLJ ZA SILIKON HOBI

Br.	Specifikacije	
38009		24

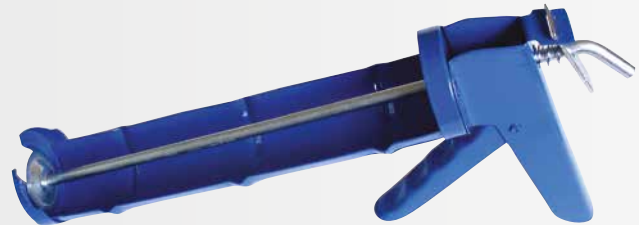

PIŠTOLJ ZA SILIKON HOBI

Br.	Specifikacije	
38000		24

**FESTA**

PIŠTOLJ ALU

Br.	Specifikacije	
38005	310 ml	20
38014	vrh 3 Kom	100

**FESTA**

PIŠTOLJ ALU

Br.	Specifikacije	
38004	600 ml	12
38014	vrh 3 Kom	100



FESTA

PISTOLJ ZA PUR PENU TEFLON

TEFLON

Br. 38018
Specifikacije



20



FESTA

PISTOLJ ZA PUR PENU TEFLON

TEFLON

Br. 38017
Specifikacije



20



TEFLON

FESTA

PIŠTOLJ ZA MONTAŽNU PENU PUR

TEFLON

Br. 38016
Specifikacije



20



TEFLON

FESTA

PIŠTOLJ OD PENE

TEFLON

Br. 38015
Specifikacije



20



PIŠTOLJ ZA MONTAŽNU PENU PUR

Br. 38031
Specifikacije



20



FESTA

PIŠTOLJ ZA MONTAŽNU PENU PUR

Br. 38022
Specifikacije
ABS

20



PIŠTOLJ PUR PENA

Br. 38021
Specifikacije

24



REZERVNA MLAZNICA ZA PIŠTOLJ ZA PU PJENU

· Za pistolj 38015, 38016, 38017, 38018

TEFLON

Br. Specifikacije

38030

5

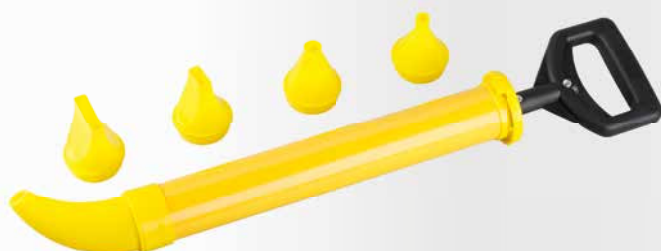

PIŠTOLJ ZA INJEKTIRANJE

· obim 1,5l



Br. Specifikacije

38026

5x vrh

25

KESA ZA FUGOVANJE



Br. Specifikacije

38042

3x vrh

6



FESTA

TOPLI VAZDUŠNI PIŠTOLJ SA REGULACIJOM TEMPERATURE

· Digitalni ekran

FESTA

TOPLI VAZDUŠNI PIŠTOLJ SA REGULACIJOM TEMPERATURE

Napon 230V / 50 Hz

Ulazna snaga 2000 W

Prekidač 0 - I (350°C) - II (600°C)

Pribor Oprema - 4 Kom

Napon 230V / 50 Hz

Ulazna snaga 2000 W

Prekidač 0 - I (50°C) - II (50 - 600°C)

Protok vazduha 250 - 500 l/min.

Pribor Oprema - 4 Kom



Br. Specifikacije

35320

2000 W



1



Br. Specifikacije

35322

2000 W



1

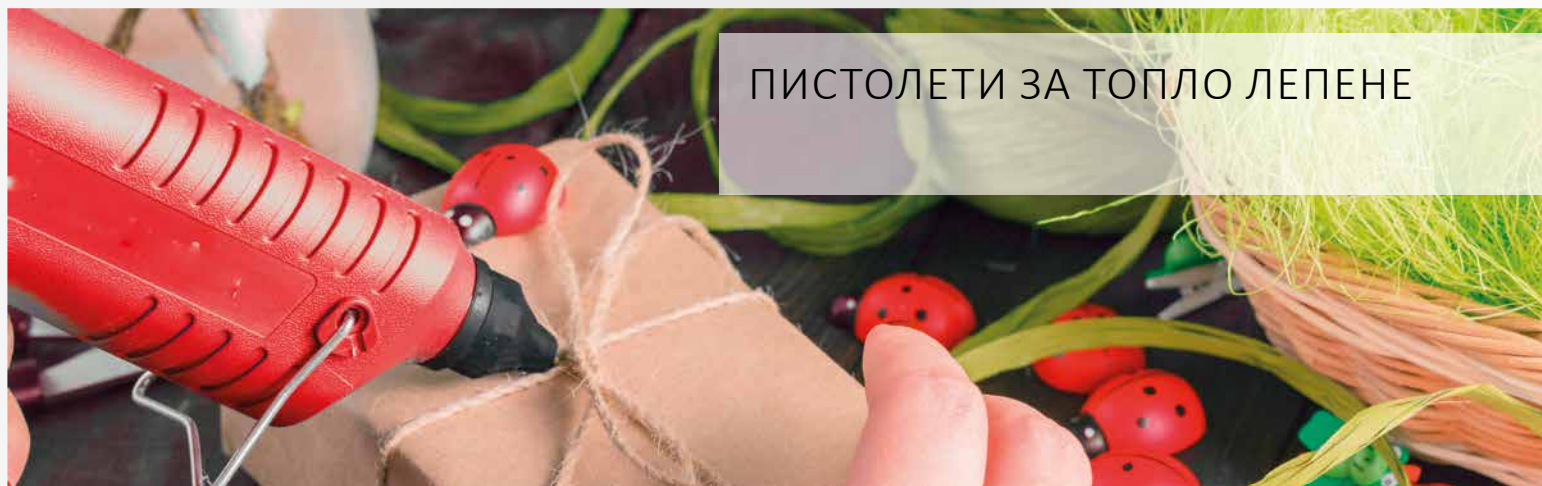

ПИСТОЛЕТИ ЗА ТОПЛО ЛЕПЕНЕ

FESTA

PISTOLJ ZA PLASTIKU - BEŽIČNI

· Ø epljivi štapić 11,2 mm



Br.	Specifikacije
89975	80 W 230 V



20



PISTOLJ ZA PLASTIKU

· Ø epljivi štapić 7,2 mm



Br.	Specifikacije
89970	15 W 230 V



25



PISTOLJ ZA PLASTIKU

· Ø epljivi štapić 11,2 mm



Br.	Specifikacije
89973	60 W 230 V



20



STAPNA MUNICIJA

Br.	Ø	Dužina		
89980	7,2 mm	100 mm	12 Kom	100
89988	7,2 mm	100 mm	1 kg	25



STAPNA MUNICIJA

Br.	Ø	Dužina		
89985	11,2 mm	200 mm	10 Kom	50
89987	11,2 mm	200 mm	1 kg	25



STAPNA MUNICIJA

Br.	Ø	Dužina		
89989	7,2 mm	100 mm	12 Kom	100
89990	11,2 mm	200 mm	10 Kom	50



ČETKI



ČETKA

Br.	Širina	Debljina	Dužina	
52212	20 mm	15 mm	40 mm	12
52213	30 mm	15 mm	45 mm	12
52214	40 mm	15 mm	45 mm	12
52215	50 mm	15 mm	50 mm	12
52216	60 mm	15 mm	60 mm	12
52217	70 mm	15 mm	65 mm	12
52218	80 mm	15 mm	65 mm	12
52220	100 mm	15 mm	70 mm	12



ČETKA

Br.	Širina	Debljina	Dužina	
52202	20 mm	12,5 mm	38 mm	12
52203	30 mm	13 mm	38 mm	12
52204	40 mm	14 mm	44 mm	12
52205	50 mm	16 mm	44 mm	12
52206	60 mm	17 mm	52 mm	12
52208	80 mm	17 mm	52 mm	12
52207	100 mm	18 mm	52 mm	12



ČETKA ZA BOJENJE RADIJATORA

Br.	Širina	Debljina	Dužina	
52283	25 mm	10 mm	44 mm	12
52284	38 mm	10 mm	44 mm	12
52285	50 mm	10 mm	44 mm	12
52286	62 mm	10 mm	50 mm	12
52288	76 mm	10 mm	50 mm	12



KOMPLET ČETKI

Br.	Specifikacije	
52070	20, 30, 50 mm	50

3x



KOMPLET ČETKI

5x



Br.	Specifikacije
52071	15 mm, 25 mm, 40 mm, 60 mm, 80 mm

50



STRUGAČ ZA BOJE I LAKOVE

Br.
37005

12



ČETKA OKRUGLA



Br.	Specifikacije
52075	Ø 90 mm

10



ČETKA ČETVRTASTA



Br.	Širina	Dužina
52076	170 mm	80 mm

10



ČETKA OKRUGLA

Br.	Specifikacije	Dužina
52077	Ø 105 mm	70 mm

12



ČETKA ČETVRTASTA

Br.	Širina	Dužina
52078	170 mm	70 mm

12

APPLICATION OF THE ROLLERS		Paints or varnishes (lacquers)												
Material	tickness of Pile mm	DISPERSION	ANTICORROSIVE	RESIN	OIL	WATER DIL.	POLYESTER	BINDER	GLAZING	LATEX	EPOXY	2-COMPONENT	THICK	ACRYLIC
PES	20	•						•		•			•	
PES	20	•	•			•		•		•				•
PAC	18	•						•		•				
PAC	12,13	•								•				
PAD	18,21	•								•				
PAD	13	•	•							•				
LAMBSKIN	23	•								•				
NYLON	13		•	•	•	•	•			•	•	•		
VELOUR	4		•	•			•				•	•	•	
MICROFIBRE	10					•			•	•				
MOLITAN				•		•								•



SET ZA FARBANJE

PAC
MADE IN EU

Br. 52600 polster 4 180 mm Ø 8 mm Ø 53 mm 18 mm 1

SET ZA FARBANJE - VESTAN

PES
MADE IN EU

Br. 52610 180 mm Ø 6 mm Ø 42 mm 20 mm 25
52605 250 mm Ø 6 mm Ø 42 mm 20 mm 20



SET ZA FARBANJE

- 1x Valjak PAD 13 mm/ 10 cm
- 1x Valjak PAC 12 mm/ 10 cm
- 1x Valjak PES 11 cm
- Drška + Posuda

MADE IN EU

Br. 52602 10



VALJAK ZA ČOŠKOVE

PAC
MADE IN EU

Br. 52601 sa drškom Ø 6 mm 18 mm 1



VALJAK POLYAKRYL

PAC MADE IN EU					
Br.					
52331	100 mm	Ø 6 mm	Ø 17 mm	12 mm	50
52334	250 mm	Ø 8 mm	Ø 48 mm	12 mm	10



VALJAK POLYAKRYL

PAC MADE IN EU					
Br.					
52391	polster 5 250 mm	Ø 8 mm	Ø 54 mm	18 mm	10



VALJAK POLYAKRYL

PAC MADE IN EU					
Br.					
52328	polster 5 250 mm	Ø 8 mm	Ø 54 mm	18 mm	10
52456	polster 7 250 mm	Ø 8 mm	Ø 67 mm	18 mm	10



VALJAK POLYAMID

PAD MADE IN EU					
Br.					
52428	polster 7 250 mm	Ø 8 mm	Ø 67 mm	18 mm	10



VALJAK POLYESTER

PES MADE IN EU					
Br.					
52315	polster 5 180 mm	Ø 8 mm	Ø 54 mm	20 mm	10



LAKIRNI VALJAK, NYLON

PAD MADE IN EU					
Br.					
52421	100 mm	Ø 6 mm	Ø 17 mm	13 mm	50
52424	250 mm	Ø 8 mm	Ø 48 mm	13 mm	10



VALJAK POLYESTER

PES MADE IN EU					
Br.					
52305	180 mm	Ø 6 mm	Ø 42 mm	20 mm	10
52306	250 mm	Ø 6 mm	Ø 42 mm	20 mm	10



VALJAK ZA LAKIRANJE, POLIESTER FINA PENA

MADE IN EU				
Br.				
52471	Ravno 100 mm	Ø 6 mm	Ø 35 mm	50

NEW

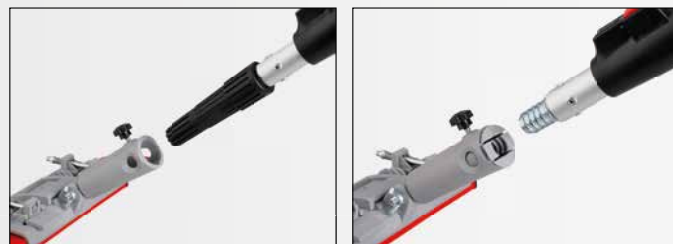

FESTA®

ŠTAP TELESKOPSKI

konac za 31610, 34203

Br.	Specifikacija
52011	88 - 140 cm



ŠTAP TELESKOPSKI

ALU

Br.	Dužina	Specifikacija	Objem
52010	120 cm	ALU	50
52012	240 cm	ALU	25



ŠTAP TELESKOPSKI

Br.	Dužina	Specifikacija	Objem
52020	300 cm	Čelik	10



ŠTAP TELESKOPSKI

Br.	Dužina	Specifikacija	Objem
52030	240 cm	fiberglass	6



KADICA ZA CEĐENJE

MADE IN EU



Br.	Specifikacije	Objem
52662	150 x 270 mm 100 mm	1
52666	260 x 290 mm 180 mm	1
52671	330 x 340 mm 250 mm	1

KANTA ZA BOJU

MADE IN EU

Br.	objem	Objem
52694	8 l	25
52695	12 l	20

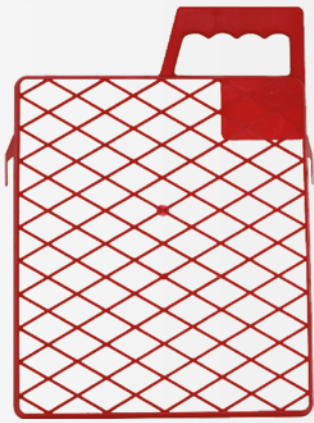

MREŽICA



Br.	Širina	Visina	
52652	230 mm	250 mm	100
52656	270 mm	290 mm	100



DRŽAČ VALJKA



Br.	Specifikacije	
52640	5 cm Ø 6 mm	100
52645	8,5 cm Ø 6 mm x 27 mm	100

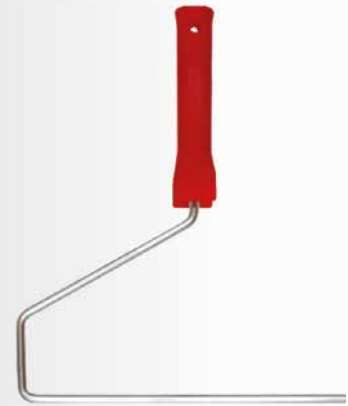

DRŽAČ VALJKA



Br.	Specifikacije	
52630	18 cm Ø 6 mm	100
52635	25 cm Ø 6 mm	100
52620	18 cm Ø 8 mm	50
52625	25 cm Ø 8 mm	50



SAMOLJ. ZAŠTITNA FOLIJA

Br.	Širina	Dužina	
37243	55 cm	30 m	60
37244	110 cm	30 m	30
37245	140 cm	30 m	30
37246	180 cm	15 m	30
37290	210 cm	20 m	30
37247	240 cm	15 m	30
37291	270 cm	16 m	30



KOMBINEZON SA KAPULJAČOM

Br.	Specifikacije	
50585	veličina M	1
50586	veličina L	1
50587	veličina XL	1
50588	veličina XXL	1



FOLIJA ZAŠTITNA

Br.	Specifikacije	
37248	1,2 x 2,2 m 100 µm Traka 45 mm x 25 m	25



FOLIJA ZAŠTITNA

Br.	objem	Debljina	
37250	4 x 5 m	0,007 mm	100
37251	4 x 12,5 m	0,007 mm	50
37252	2 x 50 m	0,007 role	20



FOLIJA ZAŠTITNA

Br.	Specifikacije	Debljina	
37253	4 x 5 m	0,03 mm	100



VALOVITI KARTON



Br.	Širina	Dužina	
54008	1 m	10 m	1



EKONOMIK ** STANDARD *** PROFI ****

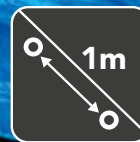

- Duplo varení spoj sa polipropilenskim kanopom
- Srebrni sloj koji odbija sunčevu svjetlost
- Alke na 1m



PE FOLIJA ZAŠTITNA EKONOMIK

· Plav



Br.	Specifikacije	
25369	2 x 2 m	50
25370	2 x 3 m	20
25371	3 x 4 m	10
25372	3 x 5 m	10
25373	4 x 5 m	10

Br.	Specifikacije	
25374	4 x 6 m	5
25376	5 x 8 m	5
25378	6 x 10 m	2
25379	8 x 12 m	2
25380	10 x 15 m	2



PE FOLIJA ZAŠTITNA STANDARD

· Plav-srebro



70 g/m²

Br.	Specifikacije		Br.	Specifikacije	
25155	2 x 2 m	50	25025	5 x 5 m	10
25006	2 x 3 m	50	25030	5 x 6 m	10
25009	3 x 3 m	35	25040	5 x 8 m	5
25012	3 x 4 m	20	25048	6 x 8 m	5
25015	3 x 5 m	10	25060	6 x 10 m	5
25016	4 x 4 m	10	25096	8 x 12 m	2
25020	4 x 5 m	10	25150	10 x 15 m	2
25024	4 x 6 m	10	25153	15 x 20 m	1



PE FOLIJA ZAŠTITNA STANDARD

· Zelen



70 g/m²

Br.	Specifikacije	
25179	2 x 2 m	50
25180	2 x 3 m	50
25195	2 x 8 m	20
25181	3 x 4 m	20
25182	3 x 5 m	10
25183	4 x 5 m	10

Br.	Specifikacije	
25184	4 x 6 m	10
25186	5 x 8 m	5
25188	6 x 10 m	5
25189	8 x 12 m	2
25190	10 x 15 m	2



PE FOLIJA ZAŠTITNA PROFÍ

· Plav-srebro



140 g/m²

Br.	Specifikacije	
25206	2 x 3 m	25
25212	3 x 4 m	10
25215	3 x 5 m	8
25220	4 x 5 m	8
25224	4 x 6 m	8
25230	5 x 6 m	8

Br.	Specifikacije	
25240	5 x 8 m	4
25248	6 x 8 m	3
25260	6 x 10 m	3
25296	8 x 12 m	2
25350	10 x 15 m	1



PE FOLIJA ZAŠTITNA PROFI

· Zelen

200 g/m²

Br.	Specifikacije		Br.	Specifikacije	
25160	2 x 3 m	15	25164	4 x 6 m	3
25171	2 x 8 m	1	25167	6 x 8 m	2
25162	3 x 5 m	5	25169	8 x 12 m	1
25163	4 x 5 m	4	25170	10 x 15 m	1

PE FOLIJA ZAŠTITNA - OKRUGLA

· Plav-srebro

120 g/m²

Br.	Specifikacije		Br.	Specifikacije	
25003	Ø 3,6 m	15	25004	Ø 4,5 m	5
25005	Ø 5,5 m	4	25002	Ø 6,5 m	3



ZATEZAČ TRAKE

4x

Br.	Specifikacije	
25400	20 cm	1



ALKE ZA ZAŠTITNU FOLIJU

Br.	Specifikacije	
25410	Aplikator ok + 25 ok	1



ALKE ZA ZAŠTITNU FOLIJU

10x

Br.	Specifikacije	
25001		1



KARABINJERI, LANCI, SPOJNICE, SAJLE ČELIČNE



SPANER SRAF

DIN 1480 Zn

Br.	Specifikacije	
50100	5 x 70 mm	10
50101	6 x 90 mm	10
50102	8 x 125 mm	10
50103	10 x 150 mm	10

Br.	Specifikacije	
50104	12 x 200 mm	10
50106	16 x 230 mm	10
50108	20 x 220 mm	10



KARABINJER

DIN 5299 C Zn

Br.	Specifikacije	
51204	4 mm	10
51205	5 mm	10
51206	6 mm	10
51207	7 mm	10
51208	8 mm	10

Br.	Specifikacije	
51209	9 mm	10
51210	10 mm	10
51211	11 mm	10
51212	12 mm	10



KARIKA NA NAVOJ

Zn

Br.	Specifikacije	
51241	4 mm	10
51242	5 mm	10
51243	6 mm	10
51244	7 mm	10

Br.	Specifikacije	
51245	8 mm	10
51246	10 mm	10
51247	12 mm	10



"S" KUKA

Zn

Br.	Specifikacije	
51271	3 mm	10
51272	4 mm	10
51273	5 mm	10
51274	6 mm	10

Br.	Specifikacije	
51275	7 mm	10
51276	8 mm	10
51278	10 mm	10



MATICA OKO

DIN 5820 Zn

Br.	Specifikacije	
51320	6 mm	10
51321	8 mm	10
51322	10 mm	10
51323	12 mm	10

Br.	Specifikacije	
51324	14 mm	10
51325	16 mm	10
51327	20 mm	10



SRAF OKO

DIN 5820 Zn

Br.	Specifikacije	
51300	6 mm	10
51301	8 mm	10
51302	10 mm	10
51303	12 mm	10
51304	14 mm	10

Br.	Specifikacije	
51305	16 mm	10
51306	18 mm	10
51307	20 mm	10
51308	22 mm	10

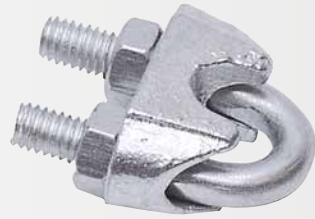

ZABICA ZA SAJLU

Zn

Br.	Specifikacije	
51280	3 mm	10
51281	5 mm	10
51282	6 mm	10
51283	8 mm	10

Br.	Specifikacije	
51284	10 mm	10
51286	12 mm	10
51287	14 mm	10
51288	16 mm	10



KARABINJER

Zn

Br.	Specifikacije	
51220	53 mm	10
51221	67 mm	10
51222	76 mm	10



OKRETNI KARABINER

Zn

Br.	Specifikacije	
51225	3,8 mm	10
51226	4,5 mm	10
51227	6,0 mm	10



LANAC KRATKA KARIKA

DIN 5685 A Zn

Br.	Veličina očiju	Dužina	
51402	2 x 10 mm	110 m	1
51403	3 x 16 mm	60 m	1
51404	4 x 21 mm	40 m	1
51405	5 x 23 mm	30 m	1

Br.	Veličina očiju	Dužina	
51406	6 x 24 mm	18 m	1
51407	7 x 50 mm	16 m	1
51408	8 x 32 mm	10 m	1
51410	10 x 39 mm	10 m	1

LANAC

DIN 5686 Zn

Br.	Ø	Dužina		Br.	Ø	Dužina	
51430	1,4 mm	150 m	1	51433	2,0 mm	118 m	1
51431	1,6 mm	150 m	1	51435	2,5 mm	70 m	1
51432	1,8 mm	150 m	1	51436	2,8 mm	50 m	1

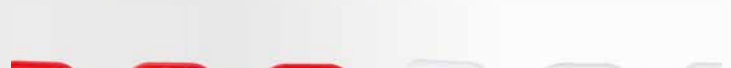

LANAC DUGA KARIKA

DIN 5685 C Zn

Br.	Veličina očiju	Dužina	
51412	2 x 12 mm	80 m	1
51413	3 x 26 mm	60 m	1
51414	4 x 32 mm	38 m	1
51415	5 x 35 mm	32 m	1

Br.	Veličina očiju	Dužina	
51416	6 x 43 mm	18 m	1
51417	7 x 50 mm	16 m	1
51418	8 x 54 mm	10 m	1
51420	10 x 65 mm	10 m	1

LANAC PLASTIČNI



Br.	Specifikacije	
51450	6 mm 25 m Crveno-beli	1



SPOJNICA ZA SAJLE I ZICU

DIN 5685 C Zn

Br.	Specifikacije	
51348	Ø 10 mm	10



SPOJNICA ZA SAJLE I ZICU

DIN 5685 C Zn

Br.	Specifikacije	
51338	Ø 5 mm	10
51341	Ø 10 mm	10



SPOJNICA ZA SAJLU

Zn

Br.	Specifikacije	
51257	Ø 14 mm	10
51258	Ø 16 mm	10
51259	Ø 18 mm	10
51260	Ø 20 mm	10
51261	Ø 22 mm	10
51262	Ø 24 mm	10
51263	Ø 26 mm	10
51264	Ø 28 mm	10
51265	Ø 30 mm	10



RUČNA DIZALICA

Zn

Br.	Kapacitet	Dužina lana	
26720	300 kg	8 m	1
26705	450 kg	8 m	1
26721	500 kg	8 m	1
26722	800 kg	8 m	1
26706	900 kg	8 m	1
26707	1350 kg	8 m	1

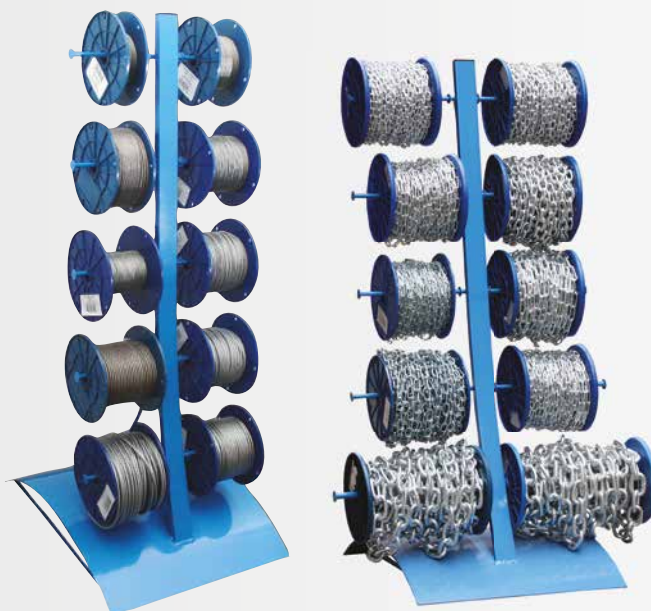

STALAK ZA SAJLE I LANCE

Br.	Specifikacije	
51196	Promotional stand for chains staffed	10
51197	Promotional stand for ropes staffed	10
51198	Promotional stand for chains	10
51199	Promotional stand for ropes	10



SAJLA ČELIČNA

Zn

Br.	Ø	Dužina	
51100	Ø 1 mm	500 m	1
51101	Ø 1,2 mm	500 m	1
51102	Ø 1,5 mm	500 m	1
51103	Ø 2 mm	200 m	1
51104	Ø 3 mm	200 m	1
51105	Ø 4 mm	100 m	1
51106	Ø 5 mm	75 m	1
51107	Ø 6 mm	75 m	1
51130	Ø 8 mm	75 m	1
51131	Ø 10 mm	50 m	1
51132	Ø 12 mm	50 m	1

SAJLA SA PVC

Zn

Br.	Ø	Dužina	
51108	Ø 2/3 mm	200 m	1
51109	Ø 3/4 mm	100 m	1
51110	Ø 4/5 mm	75 m	1
51111	Ø 5/6 mm	50 m	1



SAJLA ČELIČNA INOX

INOX

Br.	Ø	Dužina	
51120	Ø 1 mm	300 m	1
51121	Ø 1,2 mm	300 m	1
51122	Ø 1,5 mm	300 m	1
51123	Ø 2 mm	200 m	1
51124	Ø 3 mm	200 m	1
51125	Ø 4 mm	100 m	1
51126	Ø 5 mm	75 m	1
51127	Ø 6 mm	75 m	1



FESTA

REFLEKTOR LED



Br. Specifikacije

37611

1

REFLEKTOR HALOGEN



Br. Specifikacije

37600 120 W

37601 400 W

1

1

SIJALICA ZA REFLEKTOR

Br. Specifikacije

37604 120 W

37606 250 W

37605 400 W

1

1

1



FESTA

REFLEKTOR LED SA STALKOM

· Max. 180 cm



Br. Specifikacije

37615 20 W

37616 2 x 20 W

1

1

REFLEKTOR HALOGEN SA STALKOM

· Max. 180 cm

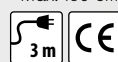

Br. Specifikacije

37602 400 W

37603 2 x 400 W



2

2



TELESKOPSKJE MERDEVINE

· max. 150 kg



Br.	Specifikacije	
48410	3,2 m 11 pregrada	1
48411	3,8 m 13 pregrada	1

TELESKOPSKJE SKLOPIVE MERDEVINE

· max. 150 kg



Br.	Specifikacije	
48415	1,9 / 3,8 m 6/12 pregrada	1



PREKLOPNA RADNA PLATFORMA

· max. 150 kg



Br.	Specifikacije	
48420		1



PODUPIRAČ

· 48449 Kavez za nosače



Br.	Specifikacije	
48452	160 - 290 cm	1
48453	180 - 320 cm	1
48454	200 - 360 cm	1
48455	250 - 440 cm	1
48456	260 - 380 cm	1
48457	220 - 400 cm	1

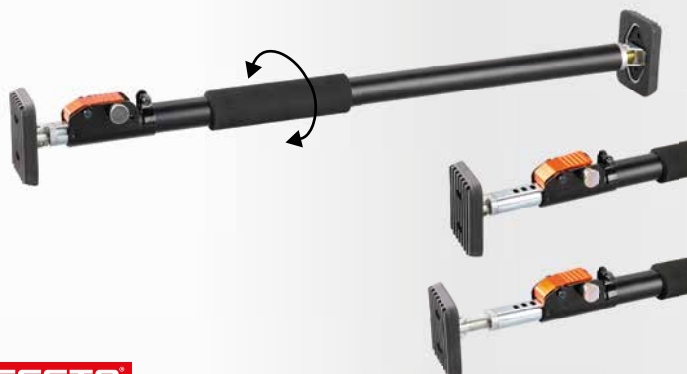

FESTA

PODUPIRAČ

· max. 40 kg



Br.	Specifikacije	
52060	66 - 115 cm	1
52065	160 - 290 cm	1



PODUPIRAČ



Br.	Specifikacije	
52050	50 - 115 cm	1
52055	115 - 290 cm	1



VIJCI ZA DRVO

Kom	
60	3,0 x 12 mm
50	3,0 x 16 mm
40	3,0 x 20 mm
50	3,5 x 20 mm
40	3,5 x 30 mm
25	4,0 x 30 mm
20	4,0 x 40 mm
15	5,0 x 50 mm
10	5,0 x 60 mm

310x

Br. Specifikacije
55642



1

VIJCI ZA DRVO + TIPLI

vijci za drvo		tipli	
Kom		Kom	
40	3,5 x 30 mm	40	5 x 25 mm
25	4,0 x 40 mm	25	6 x 30 mm
12	5,0 x 50 mm	12	8 x 40 mm
8	6,0 x 60 mm	8	10 x 50 mm

170x

Br. Specifikacije
55645



1

VIJCI ZA DRVO KOPLET

Kom	
350	3,0 x 16 mm
280	3,0 x 20 mm
220	3,0 x 25 mm
250	3,5 x 20 mm
240	3,5 x 25 mm
180	3,5 x 3, mm
280	4,0 x 16 mm
80	4,0 x 30 mm
40	4,0 x 40 mm
30	4,0 x 50 mm
25	5,0 x 50 mm
25	5,0 x 60 mm

2000x

Br. Specifikacije
55640 2000 Kom



1



VRATA ZA DIMNJAK



Br. Specifikacije
65062



1



VRATA ZA DIMNJAK KOMAX



Br. Specifikacije
65063 šedá
65064 bílá



1



VRATA ZA DIMNJAK POCINKOVANA



Br. Specifikacije
65065



1



332

WINLAND VRTNE MAKAZE



338

VRTNE MAKAZE



339

BAŠTENSKJE TESTERE



340

MAČETI, VRTNE ALAT



341

BAŠTENSKI ALATI



343

STRUNE ZA KOSILICE



344

BRUSEVI



345

ŠTAPOVI ZA PARADAJZ I
BAŠTU

346

NETKANE FOLIE



348

BAŠTENSKI PRIBOR ZA
ZALIVANJE

360

KOLICA I DRŽAČI CREVA



362

SPOJNICE ZA ZALIVNA
CREVA



364

BAŠTENSKÉ KANTE
ZA ZALIJEVANJE

365

PRSKALICE



367

GRABULJE I METLICE



372

VILE, LOPATE



378

KRAMPOVI



381

ČETKE I METLE

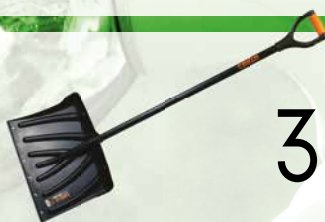

384

LOPATE ZA SNEG



386

DRZALJE



387

MREŽICE PROTIV
KOMARACA

BASTENSKI ALAT

330 - 397

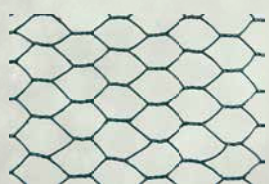

389

PLETIVA I ZICE



392

VIJAKA ZA ZEMLJU



394

MREŽA ZAŠTITNA



395

PRIBOR ZA ROSTILJ



VRTNE MAKAZE

- Profesionalne oštrice
- Visoka kvaliteta materijala
- Kvalitetna izrada
- Ergonomski rukohvati



MAKAZE

· Sečivo HCS SK - 5, japanski čelik

SK5

Br.	specifikacija	
45020	205 mm	10
44980	opruge za makaza	1



MAKAZE

· Sečivo HCS SK - 5, japanski čelik

SK5

Br.	specifikacija	
45023	205 mm	10
44980	opruge za makaza	1



MAKAZE

· Sečivo HCS SK - 5, japanski čelik

SK5

Br.	specifikacija	
45063	215 mm	10
44981	opruge za makaza	1



MAKAZE

· Sečivo HCS SK - 5, japanski čelik

SK5

TEFLON

Br.	specifikacija	
44972	215 mm	10
44981	opruge za makaza	1



MAKAZE

SK5

Br.	specifikacija	
45099	190 mm	10
44983	opruge za makaza	1



MAKAZE

SK5

Br.	specifikacija	
45098	220 mm	10
44983	opruge za makaza	1



MAKAZE

SK5

TEFLON

Br.	specifikacija	
45095	200 mm	10
44982	opruge za makaza	1



MAKAZE

• Sečivo HCS SK - 5, japanski čelik

SK5 TEFLON

Br.	specifikacija	
45096	220 mm	6
44982	opruge za makaza	1



MAKAZE

• Sečivo HCS SK - 5, japanski čelik

SK5

TEFLON

Br.	specifikacija	
45097	250 mm	10
44981	opruge za makaza	1



MAKAZE

INOX

Br.	specifikacija	
45089	160 mm	10



MAKAZE

INOX

Br.	specifikacija	
45088	160 mm	10



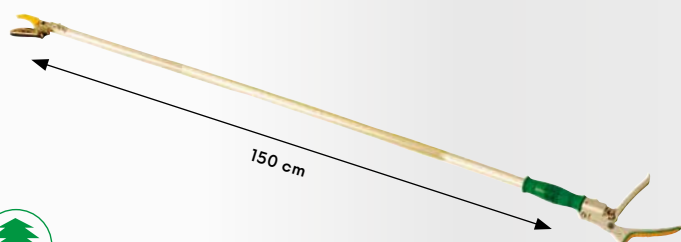

WINLAND®

MAKAZE - TELESKOPSKE

Br. specifikacija
45017



10



WINLAND®

REZERVNI NOŽEVI

• Za makaze 45095, 45027



Br. specifikacija
45094



20



WINLAND®

MAKAZE ZA GRANE

• Sečivo HCS SK - 5, japonski čelik



Br. specifikacija
44991 76 cm



12



WINLAND®

MAKAZE ZA GRANE TELESKOPSKE

• Sečivo HCS SK - 5, japonski čelik

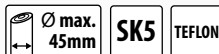

Br. specifikacija
44992 70 - 103 cm



10



WINLAND®

OPRUGE ZA MAKAZA

Br.	Za makaze	
44981	45021, 45025, 45063, 45097	1
44980	45020, 45023	1
44983	45098, 45099	1
44982	45027, 45095, 45096	1
44984	45110, 45014, 45026	1
44985	45018	1
44986	45019, 45029, 44970	1
44987	45021	1
44988	44971	1
44989	45015, 45016	1

MAKAZE ZA GRANE



WINLAND®

MAKAZE ZA ŽIVU OGRADU



Br. specifikacija
44996 61 cm, talasasto sečivo



12



MAKAZE ZA ŽIVU OGRADU



Br.	specifikacija	
44997	61 cm, ravna oštrica	12



MAKAZE ZA TRAVU OKRETNE 360°



Br.	specifikacija	
44998		6



NOŽ I DODACI ZA OSTRENJE 6 V 1



Br.	specifikacija	
45068		10



NOŽ I DODACI ZA OSTRENJE



Br.	specifikacija	
45048		20

MAKAZE



Br.	specifikacija	
45010	190 mm	12
44984	opruge za makaza	1

MAKAZE



Br.	specifikacija	
45014	190 mm	12
44984	opruge za makaza	1

MAKAZE



Br.	specifikacija	
45026	150 mm	12
44985	opruge za makaza	1

MAKAZE



Br.	specifikacija	
45018	210 mm kovane	10



MAKAZE

SK5 TEFLON



Br. 45019
specifikacija 210 mm

10



FESTA

MAKAZE

Najlonska drška

SK5 TEFLON NYLON



Br. 45021
specifikacija 200 mm

6



MAKAZE

ALU



Br. 45025
specifikacija 200 mm

12



MAKAZE

INOX



Br. 44970
specifikacija 210 mm

10



MAKAZE

TEFLON



Br. 45027
specifikacija 200 mm

10



MAKAZE

INOX ALU



Br. 44979
specifikacija 2020 mm

24



MAKAZE

INOX



Br. 44971
specifikacija 160 mm

10



MAKAZE



Br. 45016
specifikacija 180 mm

12



MAKAZE



Br.	specifikacija	
45015	190 mm, Ravne	12



NAVLAKA ZA MAKAZE

Br.	specifikacija	
37317		1



MAKAZE ZA TRAVU



Br.	specifikacija	
45011	300 mm	1



MAKAZE ZA TRAVU OKRETNE 180°



Br.	specifikacija	
45012	370 mm, Okretne 180°	1



MAKAZE ZA GRANE

· Najlonska drška



Br.	specifikacija	
44999	540 mm, oble	12



FESTA

MAKAZE ZA GRANE



Br.	specifikacija	
45000	750 mm, oble	6



FESTA

MAKAZE ZA GRANE



Br.	specifikacija	
45001	710 mm, oble	6

**FESTA**

MAKAZE ZA GRANE

TEFLON

Br.	specifikacija	
45002	750 mm, Sa graničnikom	12

**FESTA**

MAKAZE ZA GRANE TELESKOPSKE

TEFLON

Br.	specifikacija	
45003	660-900 mm, teleskopski	6



MAKAZE ZA ŽIVU OGRADU

TEFLON NYLON

Br.	specifikacija	
44995	440 160 mm	12

**FESTA**

MAKAZE ZA ŽIVU OGRADU

TEFLON

Br.	specifikacija	
45005	580 230 mm, Valovita oštrica	6



MAKAZE ZA ŽIVU OGRADU

Br.	specifikacija	
45009	500 190 mm, Valovita oštrica	6

**FESTA**

MAKAZE ZA ŽIVU OGRADU

TEFLON

Br.	specifikacija	
45006	580 230 mm, Ravna oštrica	6



MAKAZE ZA ŽIVU OGRADU

Br.	specifikacija	
45008	500 190 mm, Ravna oštrica	6

**FESTA**

MAKAZE ZA ŽIVU OGRADU TELESKOPSKE

TEFLON

Br.	specifikacija	
45007	670-870 230 mm, Valovita oštrica	6



FESTA

PREKLOPNA TESTERA



· Trostrano naoštreni zubi, termički ojačani zubi



Br.	specifikacija	
45061	150 mm	12



FESTA

TESTERA ZA GRANE PREKLOPNA



· Trostrano naoštreni zubi, termički ojačani zubi



Br.	specifikacija	
45060	180 mm	6



FESTA

TESTERA ZA GRANE



· Trostrano naoštreni zubi, termički ojačani zubi



Br.	specifikacija	
45062	260 mm	24



FESTA

TESTERA ZA GRANE



· Trostrano naoštreni zubi, termički ojačani zubi



Br.	specifikacija	
24152	300 mm	12



FESTA

TELESKOPSKA TESTERA



· Trostrano naoštreni zubi, termički ojačani zubi

Br.	specifikacija	
45033	230 - 490 cm 340 mm	1



TESTERA ZA GRANE SA KANAPOM

Br.	specifikacija	
45030	Pilka 300 mm Teleskop. mjerna šipka 240 cm	6
45031	Pilka 300 mm	6



TESTERA ZA GRANE SA KANAPOM

Br.	specifikacija	
45032	Metalna bez pile	10



FESTA
MACETA

TEFLON

Br.	specifikacija	
45069	440 mm	6

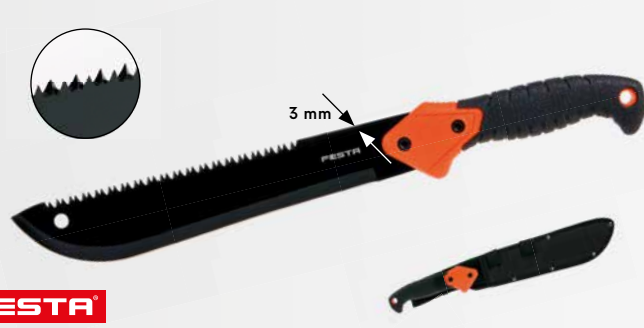

FESTA
MACETA

TEFLON

Br.	specifikacija	
44950	490 mm	4



MACETA ROSTFREI

INOX

Br.	specifikacija	
45083	430 mm	12
45084	600 mm	6



MACETA
Drvena drška (jasen)

Br.	specifikacija	
45081	510 mm	36
45082	710 mm	36



LOPATICA ŠIROKA ROSTFREI

INOX

Br.	specifikacija	
45056	360 mm	12



LOPATICA USKA ROSTFREI

INOX

Br.	specifikacija	
45057	350 mm	12



MOTIKA MALA ROSTFREI

INOX

Br.	specifikacija	
45058	270 mm	12



ALAT ZA PLJEVLJENJE SA LOPATICOM ROSTFREI

INOX

Br.	specifikacija	
45059	370 mm	12



LOPATICA ŠIROKA

NYLON

Br.	specifikacija	
45065	280 mm	1



LOPATICA USKA

NYLON

Br.	specifikacija	
45066	310 mm	1



BAŠTENSKA VILA

NYLON

Br.	specifikacija	
45067	290 mm	1



ALAT ZA CVEČE SET

HOBBY

4x

35

Br.	specifikacija	
45035	240 mm	35



SADILJKA "T"

Br.	specifikacija	
45038	280 mm	60



ŠTAP TRON. ZA PLJEVLJENJE

Br.	specifikacija	
44955	950 mm	16



NOŽ ZA KOROV

Br.	specifikacija	
45079	200 mm	1



NOŽ ZA KOROV

Br.	specifikacija	
45080	200 mm „L“	1



LOPATA NA SKLAPANJE

Navlaka

Br.	specifikacija	
61085	410 mm	6



SADILJKA

INOX

Br.	specifikacija	
45040	230 mm	60



BERAČICA ZA PLODOVE



Br.	specifikacija	
45041		75



BERAČICA ZA PLODOVE

Br.	specifikacija	
45039		50
45034	170 - 300 cm, Sa teleskop drskom	5



STRUNA ZA KOSILICU SA NAJLONSKIM CENTROM



Br.	specifikacija	
45530	2 mm x 15 m	1
45531	2,4 mm x 15 m	1
45532	3 mm x 15 m	1
45533	3,15 mm x 15 m	1
45534	4 mm x 15 m	1

STRUNA ZA KOSILICU



Br.	specifikacija	
45500	1,3 mm x 15 m	30
45502	1,3 mm x 15 m	30
45503	1,6 mm x 15 m	20
45505	1,6 mm x 15 m	20
45506	2 mm x 15 m	12
45508	2 mm x 15 m	12
45517	2 mm x 15 m	10
45509	2,4 mm x 15 m	12
45511	2,4 mm x 15 m	12
45512	2,4 mm x 15 m	12
45518	2,4 mm x 15 m	10
45523	2,7 mm x 15 m	10
45524	2,7 mm x 15 m	10
45513	3 mm x 15 m	10
45515	3 mm x 15 m	10
45516	3 mm x 15 m	10
45519	3 mm x 15 m	10



STRUNA ZA KOSILICU

Br.	specifikacija	
45520	2 mm x 162 m	10
45521	2,4 mm x 112 m	10
45528	2,7 mm x 90 m	10
45522	3 mm x 72 m	10
45525	2 mm x 162 m	10
45526	2,4 mm x 112 m	10
45529	2,7 mm x 90 m	10
45527	3 mm x 72 m	10



BRUS ZA KOSU

Br.	specifikacija	
45046	205 x 15 mm	100



BRUS ZA KOSU

Br.	specifikacija	
45370	250 x 33 x 18 mm	20

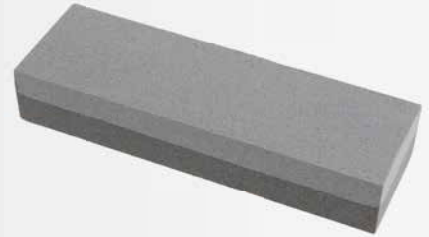

BRUS ZA KOSU

Br.	specifikacija	
45045	150 x 50 x 30 mm	10

NOŽ I DODACI ZA
OSTRENJE 6 V 1

Br.	specifikacija	
45068		10

NOŽ I DODACI ZA
OSTRENJE

Br.	specifikacija	
45048		20



BRUS

Br.	specifikacija	
16990	Ø 50 mm	50

NOŽ I DODACI ZA
OSTRENJE

Br.	specifikacija	
16991		20



TRAKA ZA VEZANJE

3x



Br.	specifikacija	
45472	3 cm x 3 m, 3 kom	36



TRAKA ZA VEZANJE



Br.	specifikacija	
45473	3 cm x 50 m	60

TRAKA ZA VEZANJE
VELCRO

Br.	specifikacija	
45471	12 mm x 5 m	1



ŽICA ZA VEZANJE PVC



Br.	specifikacija	
45043	30 m	30



ŽICA ZA VEZANJE PVC



Br.	specifikacija	
23845	3 mm x 8 m	30
23846	4 mm x 6 m	30
23847	5 mm x 4 m	30



KOLČIČ FIBERGLAS

Br.	specifikacija	
45036	180 cm Ø 7,9 mm	100



VEZICA NAZUBLJENA

50x

Br.	specifikacija	
23840		20



KOLČIČ ZA PARADAJZ SPIRALNI

Br.	specifikacija	
44041	1,2 m, Ø 5,5 mm Komaxit - green	10
44042	1,5 m, Ø 6 mm Komaxit - green	10
44043	1,8 m, Ø 6 mm Komaxit - green	10
45049	1,8 m, Ø 7 mm Komaxit - green	10
45044	1,8 m, Ø 7 mm Komaxit - silver	10
44050	2,2 m, Ø 7 mm Komaxit - green	10



SPOJNICA ZA KOLČIČE

Br.	specifikacija	
45670	8 mm	10
45671	11 mm	10
45672	16 mm	10
45673	20 mm	10



KOLČIČ PLASTIČNI

Br.	specifikacija		Br.	specifikacija		Br.	specifikacija	
45650	90 cm Ø 8 mm	25	45655	150 cm Ø 11 mm	25	45659	180 cm Ø 16 mm	25
45651	120 cm Ø 8 mm	25	45656	180 cm Ø 11 mm	25	45660	210 cm Ø 16 mm	25
45652	150 cm Ø 8 mm	25	45661	210 cm Ø 11 mm	25	45662	150 cm Ø 20 mm	10
45653	90 cm Ø 11 mm	25	45657	120 cm Ø 16 mm	25	45663	180 cm Ø 20 mm	10
45654	120 cm Ø 11 mm	25	45658	150 cm Ø 16 mm	25	45664	210 cm Ø 20 mm	10

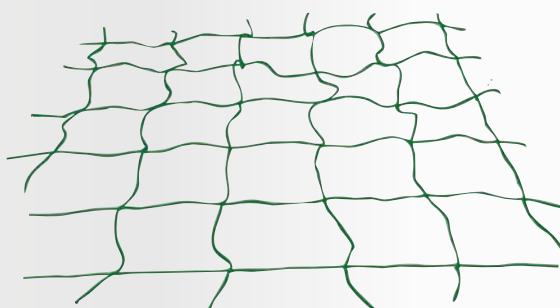

MREŽA ZAŠTITNA

Br.	specifikacija	Oko	
45560	2 x 10 m	10 x 10 cm	100

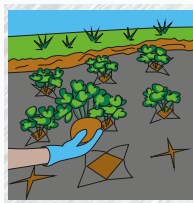

NETKANA FOLIJA

45 g/m²

Br.	specifikacija	
45535	1,6 x 5 m	18



NETKANA FOLIJA

50 g/m²

Br.	specifikacija	
45550	1,6 x 5 m	50
45551	1,6 x 10 m	20
45564	3,2 x 10 m	20
45552	1,6 x 50 m	u ulozu 1
45553	1,6 x 100 m	u ulozu 1
45562	3,2 x 50 m	u ulozu 1
45563	3,2 x 100 m	u ulozu 1



NETKANA FOLIJA

50 g/m²

Br.	specifikacija	
45556	1,6 x 5 m	50
45557	1,6 x 10 m	20
45565	3,2 x 10 m	20
45558	1,6 x 50 m	u ulozu 1
45559	1,6 x 100 m	u ulozu 1



NETKANA FOLIJA

17 g/m²

Br.	specifikacija	
45540	1,6 x 5 m	40
45541	1,6 x 10 m	40
45542	1,6 x 50 m	u ulozu 1
45543	1,6 x 100 m	u ulozu 1

PIN ZA PRIČVRŠĆIVANJE
MULČ. TKANINE**10x**

Br.	specifikacija	
45555	11,5 cm	1

BAŠTENSKA SKLOPIVA
STOLICA

• Reverzibilni

Br.	specifikacija	
45074	58 x 48 x 28 cm	4



PODLAGA

Br.	specifikacija	
45086	40 x 18 x 2 cm	50



TOVARNA KOLICA

DIMENZIJE

Visina:	111 cm
Širina:	55 cm
Zapremina rezervoara	12 l

KULTIVATOR RUČNI



KULTIVATOR RUČNI



Br.	specifikacija	12
45042	160 x 132 cm	12

Br.	specifikacija	12
44053		12
61251	160 cm drška	1

Br.	specifikacija	1
45085	12 l	1



KANTA



Br.	specifikacija	20
39192	30 l	20
39193	45 l	20

KANTA ZA LIŠČE SKLOPIVA

Br.	specifikacija	20
45047	55 x 70 cm, 3 držalje	20



SKLOPLJIVA PLATNENA KORPA

Br.	specifikacija	10
45093	40 x 25 x 23 cm	10

KESE ZA LIŠČE

Br.	specifikacija	50
44960	200 l 60 x 60 x 55 cm	50

- PROFESIONALNA ZALIVNA OPREMA
- KVALITETNI MATERIJALI
- MODERNI DIZAIN
- KOMPATIBILAN SA ROSA PROGRAMOM



PIŠTOLJ ZA PRSKANJE

- 7 funkcija
- front trigger with lock
- effortless flow control



Br. 45386 specifikacija



PIŠTOLJ ZA PRSKANJE

- adjustable flowing
- front trigger with lock
- effortless flow control



Br. 45388 specifikacija



MLAZNICA

- adjustable flowing



Br. 45389 specifikacija



KOMPLET SA MLAZNICOM

- adjustable flowing



Br. 45385 specifikacija



4 kom 12



FESTA
AQUATIC

SPOJNICA CREVO CREVO



Br. 45390
specifikacija

24

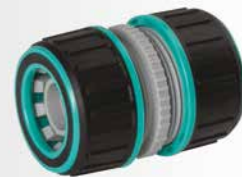

FESTA
AQUATIC

SPOJNICA CREVO CREVO



Br. 45391
specifikacija

24



FESTA
AQUATIC

SPOJNICA ČESMA CREVO



Br. 45392
specifikacija

24



FESTA
AQUATIC

SPOJNICA ČESMA CREVO



Br. 45393
specifikacija

24



FESTA
AQUATIC

SPOJNICA ČESMA CREVO STOP



Br. 45394
specifikacija

24



FESTA
AQUATIC

SPOJNICA ČESMA CREVO STOP



Br. 45395
specifikacija

24



FESTA
AQUATIC

ADAPTER



Br. 45396
specifikacija

24



FESTA
AQUATIC

ADAPTER



Br. 45397
specifikacija

24

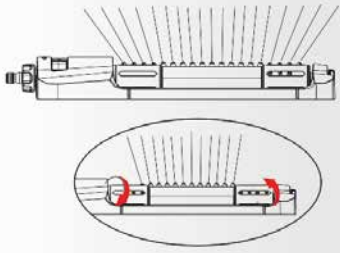

FESTA
AQUATIC
PRSKALICA

· 19 nozzles with 8 switchable (on/off) spray nozzles

2bar min 4bar max	Max 27L/min	318 m ²
----------------------	----------------	--------------------

Br. specifikacija

45398



6

FESTA
AQUATIC
PRSKALICA

· adjustable arms with nozzles

4bar max	Max 30L/min	360°	R 6m 113m ²
----------	----------------	------	---------------------------

Br. specifikacija

45399



12

FESTA
AQUATIC
RAZVODNIK

· podesivi protok vode

3/4"	1"
------	----

Br. specifikacija

45400



6



FESTA
AQUATIC
RAZVODNIK

· podesivi protok vode

3/4"	1"
------	----

Br. specifikacija

45401



6



ROSA

Watering system



ROSA
PIŠTOLJ ZA PRSKANJE

- 10 funkcija
- front trigger with lock

0,7 bar min
5,5 bar max



Br. specifikacija
45124

12



ROSA
PIŠTOLJ ZA PRSKANJE

- 10 funkcija
- trigger with lock
- podesivi protok vode

0,7 bar min
5,5 bar max



Br. specifikacija
45125

12



ROSA
PIŠTOLJ ZA PRSKANJE

- 7 funkcija
- trigger with lock

0,7 bar min
5,5 bar max



Br. specifikacija
45126

12



ROSA
PIŠTOLJ ZA PRSKANJE

- 7 funkcija
- trigger with lock
- podesivi protok vode

0,7 bar min
5,5 bar max



Br. specifikacija
45123 metal

12



ROSA
PIŠTOLJ ZA PRSKANJE

- 6 funkcija
- trigger with lock
- podesivi protok vode

0,7 bar min
5,5 bar max



Br. specifikacija
45117

12



ROSA
PIŠTOLJ ZA PRSKANJE

- 6 funkcija
- trigger with lock
- podesivi protok vode

0,7 bar min
5,5 bar max



Br. specifikacija
45118 metal head

12



ROSA

PIŠTOLJ ZA PRSKANJE

- 5 funkcija
- trigger with lock
- podesivi protok vode

0,7 bar min
5,5 bar max



Br. specifikacija

45110

12



ROSA

PIŠTOLJ ZA PRSKANJE

- Pištolj ruža
- podesivi protok vode

0,7 bar min
5,5 bar max



Br. specifikacija

45116

12



ROSA

PIŠTOLJ ZA PRSKANJE

- Metalni
- trigger with lock
- podesivi protok vode

0,7 bar min
5,5 bar max



Br. specifikacija

45120

12



ROSA

PIŠTOLJ ZA PRSKANJE

- trigger with lock
- podesivi protok vode

0,7 bar min
5,5 bar max



Br. specifikacija

45115

12



ROSA

PIŠTOLJ ZA PRSKANJE

- Metalni
- trigger with lock
- podesivi protok vode

0,7 bar min
5,5 bar max



Br. specifikacija

45122

metalni

12



ROSA

PIŠTOLJ ZA PRSKANJE + SPOJNICA

- trigger with lock
- podesivi protok vode

0,7 bar min
5,5 bar max

1/2"

2x



Br. specifikacija

45114

1/2 brza spojnica

12



ROSA

PIŠTOLJ ZA PRSKANJE

- trigger with lock
- podesivi protok vode

0,7 bar min
5,5 bar max



Br. specifikacija

45111

12



ROSA

MLAZNICA

- adjustable flowing

0,7 bar min
5,5 bar max



Br. specifikacija

45113

60



ROSA
MLAZNICA

· Klasičan spoj



Br. specifikacija
45112

32



ROSA
KOMPLET SA PIŠTOLJEM

· 6 funkcija
· trigger with lock
· podesivi protok vode



1/2" 4x



Br. specifikacija
45181

12



ROSA
KOMPLET SA MLAZNICOM

· adjustable flowing



1/2" 4x



Br. specifikacija
45180

12



ROSA
ROZDVOJKA - Y

· Sa ventilom



Br. specifikacija
45134

12



ROSA
SPOJNICA CREVO CREVO



1/2"



Br. specifikacija
45140

60



ROSA
SPOJNICA CREVO CREVO



1/2"



Br. specifikacija
45296

MOQ 20



ROSA
SPOJNICA ČESMA CREVO



1/2"



Br. specifikacija
45142

60



ROSA
SPOJNICA ČESMA CREVO



1/2"



Br. specifikacija
45298

MOQ 20



ROSA

SPOJNICA ČESMA CREVO STOP



Br. 45138 specifikacija



ROSA

SPOJNICA ČESMA CREVO STOP



Br. 45294 specifikacija

MOQ 20



MOQ 20



ROSA

SPOJNICA CREVO CREVO



Br. 45141 specifikacija



ROSA

SPOJNICA CREVO CREVO



Br. 45297 specifikacija

MOQ 20



MOQ 20



ROSA

SPOJNICA ČESMA CREVO

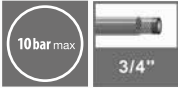

Br. 45143 specifikacija



ROSA

SPOJNICA ČESMA CREVO



Br. 45299 specifikacija

MOQ 20



MOQ 20



ROSA

SPOJNICA ČESMA CREVO STOP



Br. 45139 specifikacija



ROSA

SPOJNICA ČESMA CREVO STOP



Br. 45295 specifikacija

MOQ 20



MOQ 20



ROSA

ADAPTER



Br.	specifikacija	
45130	1/2" + 3/4"	60
45131	3/4" + 1"	60



ROSA

ADAPTER



Br.	specifikacija	
45289	1/2" + 3/4"	MOQ 20
45290	3/4" + 1"	MOQ 20

MOQ 20



ROSA

SPOJNICA I ADAPTER



2x



Br.	specifikacija	
45144		60



ROSA

SPOJNICA REDUCIR 1/2" - 3/4"



Br.	specifikacija	
45213	1/2" - 3/4"	60



ROSA

KONEKTOR SA VENTILOM

with water valve



Br.	specifikacija	
45135		60



ROSA

ADAPTER SA ŠELNOM



Br.	specifikacija	
45145		60



ROSA

ADAPTER



Br.	specifikacija	
45132		60



ROSA

ADAPTER



Br.	specifikacija	
45291		MOQ 20

MOQ 20





ROSA

ADAPTER SA SPOLJNIM NAVOJEM



Br. specifikacija
45133

60



ROSA

ADAPTER SA SPOLJNIM NAVOJEM



Br. specifikacija
45292

MOQ 20



ROSA

SPOJNICA



Br. specifikacija
45136

60



ROSA

SPOJNICA



Br. specifikacija
45293

MOQ 20



ROSA

SPOJNICA



Br. specifikacija
45137

60



ROSA

SPOJNICA



Br. specifikacija
45215

48



ROSA

SPOJNICA



Br. specifikacija
45218

48



ROSA

SPOJNICA ČESMA CREVO



Br. specifikacija
45219

48



ROSA

SPOJNICA REDUCIR 3/4" - 1"



Br. 45216 specifikacija 48



ROSA

ADAPTER



Br. 45217 specifikacija 48

ROSA

PRODAJNI SET

· Sadržaj kompleta:

- 45113 15 kom
- 45117 10 kom
- 4512015 kom
- 4513240 kom
- 4513140 kom
- 4513340 kom
- 4514225 kom
- 4514320 kom
- 4514020 kom



225x

Br. 45146 specifikacija 1



ROSA

PRSKALICA

· adjustable flowing



Br. 45214 specifikacija 48

ROSA

PRSKALICA

· Impulsna



Br. 45162 specifikacija 24



ROSA

PRSKALICA

· 8 funkcija



Br. 45154 specifikacija 48



ROSA

PRSKALICA

· Rotaciona
· 2 ramena



Br. 45153 specifikacija 24



ROSA

PRSKALICA

· Rotaciona
· 3 ramena



Br. 45152 specifikacija 24





ROSA

PRSKALICA ROTACIONA

· 17 rupa

0,7 bar min
5,5 bar max

ALU



Br. specifikacija

45158

6



ROSA

PRSKALICA

· Piramida

0,7 bar min
5,5 bar max



Br. specifikacija

45167

12



ROSA

PRSKALICA

· Ubodna

0,7 bar min
5,5 bar max



Br. specifikacija

45160

25



ROSA

PRSKALICA SA VENILOM

· Sa ventilom

0,7 bar min
5,5 bar max



Br. specifikacija

45156

12



ROSA

POSTOLJE ZA IMPULSNU PRSKALICU

0,7 bar min
5,5 bar max

3/4"



Br. specifikacija

45155

24



ROSA

PRSKALICA

· Sa stativom

0,7 bar min
5,5 bar max



Br. specifikacija

45163 impuls na stativu

20



ROSA

TIMER

· 0 - 120 min.

0,7 bar min
5,5 bar max

3/4"



Br. specifikacija

45147

24



ROSA

PRSKALICA IMPULSNA

· Mesing

0,7 bar min
5,5 bar max

3/4"



Br. specifikacija

45150

12



ROSA
PRSKALICA IMPULSNA

0,7 bar min
5,5 bar max
3/4"

Br.	specifikacija	
45151		12

ROSA
PRSKALICA UBODNA MLAZNA

0,7 bar min
5,5 bar max
3/4"

Br.	specifikacija	
45168	Plastična	12
45169	Metalna	12



ROSA
PRSKALICA UBODNA IMPULSNA

0,7 bar min
5,5 bar max

Br.	specifikacija	
45161	plastový hrot	20

ROSA
PRSKALICA UBODNA, ROTACIONA

· 3 ramena
· Dvosmerni

0,7 bar min
5,5 bar max
3/4"

Br.	specifikacija	
45164	Plastična	12



ROSA
TELO PRSKALICE POC.

3/4" Zn

Br.	specifikacija	
45159		12

ROSA
TELO PRSKALICE PLAST.

3/4"

Br.	specifikacija	
45179		12

ROSA
USMERIVAC CREVA

Br.	specifikacija	
45186		48

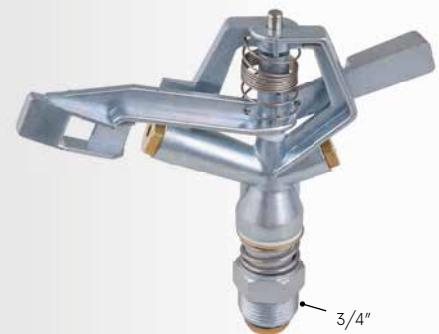

ROSA
PRSKALICA IMPULSNA METALNA

1"

Br.	specifikacija	
45185		20

ROSA
PRSKALICA IMPULSNA METALNA

3/4"

Br.	specifikacija	
45184		20

ROSA

KOMPLET DIHTUNGA

· Za artikal

- 45110, 45111, 45118,
- 45120, 45121, 45123,
- 45125, 45126, 45130,
- 45131, 45132, 45134,
- 45135, 45152, 45153,
- 45154, 45155, 45156,
- 45162, 45177, 45178,
- 45180, 45196, 45197,
- 45198



ROSA

DIHTUNZI ZA SPOJNICE

50x

Br.	specifikacija	
45175		1

Br.	specifikacija	
45187		1



ROSA

DRŽAČ BAS.CREVA

Br.	specifikacija	
45182	1/2" 40 m	4



ROSA

CREVO ZA POLIVANJE SA AUTOMATSKIM VRAĆANJEM

· Uključujući crevo 1/2" 20 m

0,7bar min	
5,5bar max	1/2"

Br.	specifikacija	
45176		1



ROSA

MOTALICA ZA CREVO SA TOČKOM

Br.	specifikacija	
45183	1/2" 60 m	5



ROSA

MOTALICA ZA CREVO SA TOČKOM

Br.	specifikacija	
45177	1/2" 60 m	5



ROSA

MOTALICA ZA CREVO

Br.	specifikacija	
45178	1/2" 60 m	5



ROSA
TUŠ BAŠTENSKI 1 NOGA

0,7bar min
5,5bar max

Br.	specifikacija	
45171	Podesiva	12



ROSA
TUŠ BAŠTENSKI 3 NOGE

0,7bar min
5,5bar max

Br.	specifikacija	
45170	3 noge	6



ROSA
TUŠ RUČNI SA VENILOM

0,7bar min
5,5bar max

Br.	specifikacija	
45172	Sa ventilom	12
45173	10 funkcija	12



ROSA
DRŽAČ BAS.CREVA

Br.	specifikacija	
45174		60



CREVO ZA POLIVANJE
TRANSPARENTAN



Br.	specifikacija	
45345	1/2" 25 m	1
45349	3/4" 25 m	1
45353	1" 25 m	1



CREVO ZA POLIVANJE
NE TRANSPARENTAN



Br.	specifikacija	
45360	1/2" 25 m	1
45364	3/4" 25 m	1
45366	1" 25 m	1



ROSA
SPIRALNO CREVO SET

0,7bar min
5,5bar max

Br.	specifikacija	
45300	7,5 m	6
45301	15 m	8



NOSAČ CREVA

• Max nosivost 30m creva 1/2"

Br.	specifikacija	
45350	Max. nosivost 20 kg	1



ROSA

SPOJNICA CREVO CREVO MS



Br. 45192 specifikacija 48



ROSA

SPOJNICA ČESMA CREVO MS



Br. 45194 specifikacija 48



ROSA

SPOJNICA CREVO ČESMA STOP MS



Br. 45190 specifikacija 48



ROSA

SPOJNICA ČESMA CREVO MS



Br. 45193 specifikacija 48



ROSA

SPOJNICA ČESMA CREVO MS



Br. 45195 specifikacija 48



ROSA

SPOJNICA CREVO ČESMA STOP MS



Br. 45191 specifikacija 48



ROSA

ADAPTER MS



Br. 45196 specifikacija Sa unutrašnjim navojem 1/2" + 3/4" 48



ROSA

ADAPTER MS



Br. 45197 specifikacija Sa unutrašnjim navojem 3/4" 48



ROSA

ADAPTER MS



Br. 45199 specifikacija Sa unutrašnjim navojem 1" 48



ROSA

ADAPTER MS



Br. 45198 specifikacija Sa unutrašnjim navojem 3/4 + 1" 48



ROSA

ADAPTER MS



Br. 45200 specifikacija Sa spoljnim navojem 3/4 48



ROSA

PRSKALICA MS



Br. 45206 specifikacija Podesiva 48



ROSA

SPOJNICA KLASIČNA MS



Br.	specifikacija	
45203	Spojnicica za 2 creva	48



ROSA

SPOJNICA KLASIČNA MS



Br.	specifikacija	
45204	Spojnicica za 3 creva	48



SPOJNICA



Br.	specifikacija	
45211	unutrašnji navoj 1"	25



SPOJNICA CREVA KLASIČNA

Br.	specifikacija	
45220	1/2" navoj 3/4"	10
45221	3/4" navoj 1"	10
45222	1" navoj 1"	10



ADAPTER

Br.	specifikacija	
45223	1/2" navoj 3/4"	10
45224	3/4" navoj 1"	10
45225	1" navoj 1"	10



REDUCIR ZA BAS.CREVO

Br.	specifikacija	
45226	1/2" - 3/4" zavit 1"	10
45227	1" - 3/4" zavit 1"	10
45228	1" - 1/2" zavit 1"	10



MLAZNICA ZA CREVO

Br.	specifikacija	
45229		10



ŠELNA POCINKOVANA

Br.	Prečnika	MOQ
45600	8 - 12 mm	2
45601	10 - 16 mm	2
45602	12 - 20 mm	2

Br.	Prečnika	
45603	16 - 25 mm	2
45604	20 - 32 mm	2
45605	25 - 40 mm	2
45606	30 - 45 mm	2
45607	32 - 50 mm	2
45608	40 - 60 mm	2
45609	50 - 70 mm	2
45610	60 - 80 mm	2
45611	70 - 90 mm	2
45612	80 - 100 mm	2
45613	90 - 110 mm	2
45614	100 - 120 mm	2
45615	110 - 130 mm	2
45616	120 - 140 mm	2
45617	130 - 150 mm	2
45618	140 - 160 mm	2
45619	150 - 170 mm	2



ŠELNA NERĐAJUĆA

Br.	Prečnika	Širina	MOQ
45620	8 - 12 mm	9 mm	2
45621	10 - 16 mm	9 mm	2
45622	12 - 20 mm	9 mm	2

Br.	Prečnika	Širina	
45623	16 - 25 mm	9 mm	2
45624	20 - 32 mm	9 mm	2
45625	25 - 40 mm	12 mm	2
45626	30 - 45 mm	12 mm	2
45627	32 - 50 mm	12 mm	2
45628	40 - 60 mm	12 mm	2
45629	50 - 70 mm	12 mm	2
45630	60 - 80 mm	12 mm	2
45631	70 - 90 mm	12 mm	2
45632	80 - 100 mm	12 mm	2
45633	90 - 110 mm	12 mm	2
45634	100 - 120 mm	12 mm	2
45635	110 - 130 mm	12 mm	2
45636	120 - 140 mm	12 mm	2
45637	130 - 150 mm	12 mm	2
45638	140 - 160 mm	12 mm	2
45639	150 - 170 mm	12 mm	2



BAŠTENSKI PRIBOR ZA ZALIVANJE



SLAVINA KUGLA

Br.	specifikacija	
45105		8



SLAVINA KUGLA

Br.	specifikacija	
45100	1/2"	12
45101	3/4"	10
45102	1"	6



KUGLA VENTIL

Br.	specifikacija	
45106	1/2"	12
45107	3/4"	10
45108	1"	8



VENTIL UGAONI

Br.	specifikacija	
45104	1/2" x 3/8"	10



KANTA PLASTIČNA



Br.	specifikacija	
45280	2,5 l	10
45283	5 l	10
45285	10 l	10
45286	12 l	10
45287	15 l	10



FESTA

**RUČNI PERAČ
POD PRITISKOM 12L**

Max pritisk	2,5 Bar
Kapacitet	12 l
Dužina creva	3 m
Mere	32 x 25 x 59 cm



Br.	specifikacija	
45249	ručni perač pod pritiskom 12 l	1
45273	spare nozzle	1
45274	spare pressure hose	1

FESTA

**ELEKTRIČNI PERAČ
POD PRITISKOM**

napěti/ frekvence	230 V/50 Hz
přikon	1500 W
maximalní tlak	120 Bar
pracovní tlak	80 Bar
průtok vody	6 l
délka hadice	5 m
krytí	IPX5
funkce	Auto Stop



Br.	specifikacija	
45270	električni perač pod pritiskom	1
45271	spare nozzle	1
45272	spare pressure hose	1



FESTA

PRSKALICA SA PRITISKOM

Br.	specifikacija	
45247	12 l	1
45248	16 l	1



Br.	specifikacija	
45263	Rezervno crevo za prskalicu	1
45251	Rezervni komplet brtvljenja	1
45254	Rezervna plastična mlaznica	1
45257	Plastična drška	1
45260	Rezervni štap - 370 mm	1
45267	Rezervni štap 45 - 250 cm	1
45268	Rezervni štap 65 - 260 cm	1



FESTA

PRSKALICA SA PRITISKOM

Br.	specifikacija	
45244	3 l	6
45245	5 l	6
45246	8 l	6



Br.	specifikacija	
45262	Rezervno crevo za prskalicu	1
45250	Rezervni komplet brtvljenja	1
45253	Rezervna plastična mlaznica	1
45256	Plastična drška	1
45261	Rezervni štap - 370 mm	1

**FESTA**

PRSKALICA SA PRITISKOM

Br.	typ	
45242	1,5 l	20
45241	2 l	20



ŠTAP ZA PRSKALICU

Br.	typ		
45267	45 - 250 cm	inox	1
45268	65 - 260 cm	fiberglass	1



REZERVNO CREVO ZA PRSKALICU

Br.	typ	
45263	Za prskalicu 45247, 45248	1
45262	Za prskalicu 45244, 45245, 45246	1



PRSKALICA FAJTALICA



Br.	typ	
45239	0,5 l	1
45240	0,7 l	1

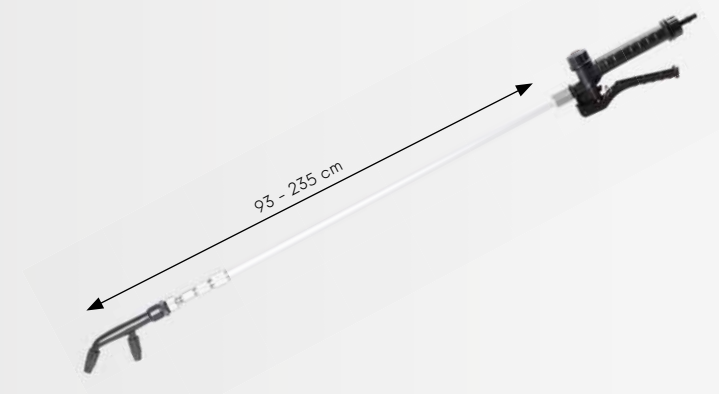

ŠTAP ZA PRSKALICU

Br.	specifikacija	
45269		1



ZVONO ZA PRSKANJE

Br.	velikost	Dužina	Širina	visina	
45265	small	230 mm	90 mm	130 mm	1
45266	big	370 mm	140 mm	200 mm	1

FESTA[®]



RAKE



FESTA

GRABLJE METLICA

Br.	Broj letvica	Širina	visina	
45327	13	240 mm	200 mm	12



FESTA

GRABLJE METLICA SA ALU DRŠKOM

MOQ
3

Br.	Broj letvica	Dužina drške	
61136	13	160 cm	3
61147	13	100 cm	3



FESTA

GRABLJE METLICA

Br.	Broj letvica	Širina	visina	
45328	23	480 mm	280 mm	12



FESTA

GRABLJE METLICA SA ALU DRŠKOM

MOQ
3

Br.	Broj letvica	Dužina drške	
61137	23	160 cm	3
61148	23	100 cm	3



FESTA

GRABLJE METLICA

Br.	Broj letvica	Širina	visina	
45329	35	760 mm	310 mm	1



FESTA

GRABLJE METLICA SA ALU DRŠKOM

MOQ
3

Br.	Broj letvica	Dužina drške	
61138	35	160 cm	3

**FESTA**

GRABLJE PLASTIČNE

Br.	Broj letvica	Širina	
45325	12	410 mm	12

**FESTA**

GRABLJE PVC SA ALU DRŠKOM

MOQ
3

Br.	Broj letvica	Dužina drške	
61139	12	160 cm	3

**FESTA**

GRABLJE PLASTIČNE

Br.	Broj letvica	Širina	
45326	18	580 mm	12

**FESTA**

GRABLJE PVC SA ALU DRŠKOM

MOQ
3

Br.	Broj letvica	Dužina drške	
61140	18	160 cm	3



PAJALICA

Br.	specifikacija	
45323	37 cm	16



PAJALICA SA ALU DRŠKOM

MOQ
3

Br.	specifikacija	Dužina drške	
61149	37 cm	160 cm (45330)	3

**FESTA**

GRABLJE METLICE TELESKOP PODESIVE

Zn

Br.	Broj letvica	rozsah	
44965	15	200 - 590 mm	12



GRABLJE METLICE PODESIVE

Zn

Br.	Broj letvica	váha	rozsah	
45050	15	1200 g	200 - 590 mm	25



FESTA

GRABLJE - METLICA

· Opružni čelik

Br.	Širina	Broj letvica	
45071	55 cm	22	1



FESTA

GRABLJE - METLICA SA DRVENOM DRŠKOM

MOQ
3

Br.	Širina	Dužina drške	
61150	55 cm	160 cm	3



GRABLJE - METLICA

Br.	Širina	Broj letvica	
45051	40 cm	22	60



GRABLJE - METLICA SA DRVENOM DRŠKOM

MOQ
3

Br.	Širina	Dužina drške	
61130	40 cm	160 cm	3



GRABLJE - METLICA

Br.	Širina	Broj letvica	
45052	45 cm	22	36



GRABLJE - METLICA SA DRVENOM DRŠKOM

MOQ
3

Br.	Širina	Dužina drške	
61131	45 cm	160 cm	3



GRABLJE - METLICA

MADE IN
EU

Br.	Širina	Broj letvica	
45320	60 cm	24	10



GRABLJE - METLICA SA DRVENOM DRŠKOM

MADE IN
EU

MOQ
3

Br.	Širina	Broj letvica	Dužina drške	
61132	60 cm	24	160 cm	3



GRABLJE - METLICA

MADE IN
EU

Br.	Širina	Broj letvica	
45055	50 cm	22	10



GRABLJE - METLICA SA DRVENOM DRŠKOM

MADE IN
EU

MOQ
3

Br.	Širina	Broj letvica	Dužina drške	
61133	50 cm	22	160 cm	3



GRABLJE - METLICA



Br.	Širina	Broj letvica	
45321	40 cm	23	20



GRABLJE - METLICA SA DRVENOM DRŠKOM

MOQ
3

Br.	Broj letvica	Dužina drške	
61134	23	160 cm	3



GRABLJE - METLICA



Br.	Širina	Broj letvica	
45054	40 cm	23	10



GRABLJE - METLICA SA DRVENOM DRŠKOM

MOQ
3

Br.	Širina	Broj letvica	Dužina drške	
61135	40 cm	23	160 cm	3



GRABLJE



Br.	Širina	Broj letvica	
45053	58 cm	16	35



GRABLJE SA DRVENOM DRŠKOM

MOQ
3

Br.	Širina	Broj letvica	Dužina drške	
61141	58 cm	16	160 cm	3



GRABLJE



Br.	Širina	Broj letvica	
45070	41 cm	14	4



GRABLJE SA DRVENOM DRŠKOM

MOQ
3

Br.	Širina	Broj letvica	Dužina drške	
61142	41 cm	14	160 cm	3



GRABLJE

Br.	Širina	Broj letvica	
61030	24 cm	10	24
61031	29 cm	12	24
61032	34 cm	14	24
61033	40 cm	16	24



GRABLJE SA DRVENOM DRŠKOM

MOQ
3

Br.	Širina	Broj letvica	Dužina drške	
61060	24 cm	10	160 cm	3
61061	29 cm	12	160 cm	3
61062	34 cm	14	160 cm	3
61063	40 cm	16	160 cm	3



GRABLJE

• Boja čekića

Br.	Širina	Broj letvica	
61045	30 cm	12	25
61046	39 cm	14	25
61047	45 cm	16	25



GRABLJE SA DRVENOM DRŠKOM

• Boja čekića

MOQ
3

Br.	Širina	Broj letvica	Dužina drške	
61143	30 cm	12	160 cm	3
61144	39 cm	14	160 cm	3
61145	45 cm	16	160 cm	3



GRABLJE

Br.	Širina	Broj letvica	
61048	35 cm	11 21	12



GRABLJE SA DRŠKOM

MOQ
3

Br.	Širina	Broj letvica	Dužina drške	
61146	35 cm	11 21	160 cm	3



GRABLJE FIBERGLASS DRŠKA

MOQ
3

Br.	Širina	Broj letvica	Dužina drške	
61034	34 cm	14	160 cm	3

LOPATE I VILE

FESTA®

FESTA®

AŠOV

· Pogodan za stakleničke radove

Br.	specifikacija	Dužina drške	
61008	19 x 28 cm	85 cm	5



FESTA®

AŠOV

Br.	specifikacija	Dužina drške	
61005	20 x 29 cm	120 cm	5



FESTA®

AŠOV

Br.	specifikacija	Dužina drške	
61006	19 x 28 cm	120 cm	5



FESTA®

AŠOV

· Za osobu veću od 180 cm

Br.	specifikacija	Dužina drške	
61157	20 x 29 cm	130 cm	5

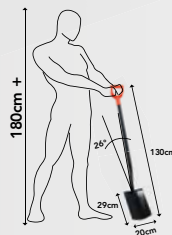

FESTA®

AŠOV

Br.	specifikacija	Dužina drške	
61158	19 x 28 cm	130 cm	5

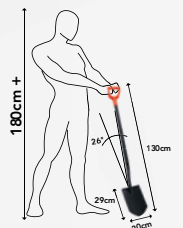

FESTA®

LOPATA STANDARD

Br.	specifikacija	Dužina drške	
61155	24 x 29 cm	120 cm	5



FESTA®

VILE

Br.	specifikacija	Dužina drške	
61156	19 x 28 cm	130 cm	5





FESTA

VILE

Br.	specifikacija	Dužina drške	
61007	18 x 28 cm	130 cm	5



VILE

Br.	specifikacija	Dužina drške	
61010	18 x 30 cm	95 cm	12



AŠOV

Br.	specifikacija	Dužina drške	
61029	19 x 30 cm	95 cm	12



AŠOV

Br.	specifikacija	Dužina drške	
61015	19 x 30 cm	95 cm	12



LOPATA ALUMINIJUMSKA



Br.	specifikacija	
61026	26 x 29 cm	10
61025	34 x 30 cm	10



LOPATA ALUMINIJUMSKA

· Drška bukva



MOQ
3

Br.	specifikacija	Dužina drške	
61057	26 x 29 cm	130 cm	3
61056	34 x 30 cm	130 cm	3



LOPATA ZA UGALJ

Br.	specifikacija	
61021	35 x 35 cm	10



LOPATA ZA UGALJ

MOQ
3

Br.	specifikacija	Dužina drške	
61089	35 x 35 cm	130 cm	3



LOPATA ŠPICASTA

- Boja čekića
- Drška bukva

MOQ
3

Br.	specifikacija	Dužina drške	
61050	26 x 28 cm	130 cm	3

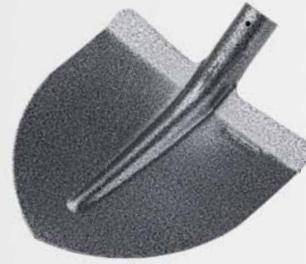

LOPATA ŠPICASTA

- Boja čekića

Br.	specifikacija	
61000	26 x 28 cm	12



LOPATA ŠPICASTA

- Drška bukva

MOQ
3

Br.	specifikacija	Dužina drške	
61088	26 x 28 cm	130 cm	3



LOPATA ŠPICASTA

Br.	specifikacija	
61020	26 x 28 cm	12



LOPATA STANDARD

- Boja čekića
- Drška bukva

MOQ
3

Br.	specifikacija	Dužina drške	
61051	24 x 29 cm	130 cm	3



LOPATA STANDARD

- Boja čekića

Br.	specifikacija	
61001	24 x 29 cm	12



LOPATA STANDARD

- Drška bukva

MOQ
3

Br.	specifikacija	Dužina drške	
61090	24 x 29 cm	130 cm	3
61053	24 x 29 cm	130 cm "T _n " Drška	3



LOPATA STANDARD

Br.	specifikacija	
61022	24 x 29 cm	12





LOPATA

Br.	specifikacija	
61058	25 x 27 cm	12



LOPATA

· Drška bukva

MOQ
3

Br.	specifikacija	Dužina drške	
61059	25 x 27 cm	130 cm	3



LOPATA USKA

· Boja čekića

Br.	specifikacija	
61002	19 x 27 cm	12



LOPATA USKA

· Boja čekića
· Drška bukva

MOQ
3

Br.	specifikacija	Dužina drške	
61052	19 x 27 cm	130 cm	3



LOPATA USKA

Br.	specifikacija	
61024	19 x 27 cm	12



LOPATA USKA

MOQ
3

Br.	specifikacija	Dužina drške	
61054	19 x 27 cm	130 cm	3



AŠOV

· Boja čekića

Br.	specifikacija	
61004	22 x 30 cm	12



AŠOV

· Boja čekića

MOQ
3

Br.	specifikacija	Dužina drške	
61161	22 x 30 cm	90 cm	3



AŠOV

MOQ
3

Br.	specifikacija	Dužina drške	
61097	19 x 30 cm	90 cm	3



AŠOV

Br.	specifikacija	
61019	22 x 30 cm	12



AŠOV KOVANI

Br.	specifikacija	Dužina drške	MOQ
61162	22 x 25 cm	90 cm	3
61223	drška	90 cm	1



AŠOV KOVANI

Br.	specifikacija	
61013	22 x 25 cm	12



AŠOV

· Boja čekića

MOQ
3

Br.	specifikacija	Dužina drške	
61163	21 x 30 cm	90 cm	3



AŠOV

· Boja čekića

Br.	specifikacija	
61003	21 x 30 cm	12



AŠOV

MOQ
3

Br.	specifikacija	Dužina drške	
61098	21 x 30 cm	90 cm	3



AŠOV

Br.	specifikacija	
61018	21 x 30 cm	12





AŠOV

Br.	specifikacija	
61014	14 x 37 cm	12



AŠOV

Br.	specifikacija	Dužina drške	
61164	14 x 37 cm	90 cm	MOQ 3
61203	drška	90 cm	1



VILE

Br.	specifikacija	
61009	20 x 32 cm	12



VILE

Br.	specifikacija	Dužina drške	
61165	20 x 32 cm	90 cm	MOQ 3 3



KOVANA VILA

Br.	specifikacija	
61012	22 x 30 cm	12



KOVANA VILA

Br.	specifikacija	Dužina drške	
61166	22 x 30 cm	90 cm	MOQ 3
61222	drška	90 cm	1



VILE

Br.	specifikacija	
61044	20 x 30 cm	12



VILE

Br.	specifikacija	Dužina drške	
61028	20 x 30 cm	90 cm	MOQ 3
61209	drška	90 cm	1



MOTIKA KOVANA ŠPICASTA

Br.	specifikacija	Dužina drške	MOQ	
61111	0,4 kg	120 cm	3	
61112	0,6 kg	120 cm	3	
61224	drška	120 cm	1	



MOTIKA KOVANA ŠPICASTA

Br.	specifikacija	A	B	MOQ	
61035	0,4 kg	180 mm	125 mm	1	
61036	0,6 kg	230 mm	160 mm	30	

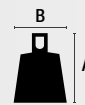

MOTIKA KOVANA ČETVRTASTA SA DRŠKOM

Br.	specifikacija	Dužina drške	MOQ	
61114	0,6 kg	120 cm	3	
61224	drška	120 cm	1	

MOTIKA KOVANA ČETVRTASTA

Br.	specifikacija	A	B	MOQ	
61038	0,6 kg	165 mm	135 mm	20	



KRAMP

MOQ
3

Br.	specifikacija	Dužina drške	MOQ	
61121	1,5 kg	95 cm	3	
61042	2,5 kg	95 cm	3	

KRAMP

Br.	specifikacija	MOQ	
61120	1,5 kg	6	
61040	2,5 kg	6	





MOTIKA

Br.	specifikacija	
61067	75 mm	1
61068	125 mm	1
61069	175 mm	1



MOTIKA

MOQ
3

Br.	specifikacija	Dužina drške	
61290	75 mm	120 cm	3
61291	125 mm	120 cm	3
61292	175 mm	120 cm	3



MOTIKA

Br.	specifikacija	
61070	140 mm	40



MOTIKA

MOQ
3

Br.	specifikacija	Dužina drške	
61293	140 mm	120 cm	3



MOTIKA

Br.	specifikacija	Dužina drške	
61294	140 mm	27 cm	MOQ 3
61221	drška	27 cm	1



MOTIKA

Br.	specifikacija	Dužina drške	
61295	140 mm	27 cm	MOQ 3
61221	drška	27 cm	1



MOTIKA

Br.	specifikacija	Dužina drške	
61296	175 mm	27 cm	MOQ 3
61221	drška	27 cm	1



MOTIKA

Br.	specifikacija	Dužina drške	
61297	175 mm	27 cm	MOQ 3
61221	drška	27 cm	1



120 cm

80 cm



Illustration photo

REKLAMNA POLICA ZA LOPATE I AŠOVE

Br.	specifikacija	
61077	stand with shovels, spades	1
61079	stand with pallet	1



Illustration photo

DRŽAČ ZA BAŠTENSKI ALAT

Br.	specifikacija	
51185	45 cm	15



• Rotirajuće gumene valjke

DRŽAČ ZA BAŠTENSKI ALAT

5x

Br.	specifikacija	
51184		12



SRP

Br.	specifikacija	
45490	450 mm	1



FESTA
METLA ŽIČANA

Br.	specifikacija		
22135	6 x 19 cm	wihout handle	8
22137	6 x 19 cm	with handle 140 cm	MOQ 3



FESTA
METLA PVC

Br.	specifikacija		
22136	6 x 19 cm	wihout handle	8
22138	6 x 19 cm	with handle 140 cm	MOQ 3



ČEL. ČETKA ZA ČIŠČENJE PLOČNIKA

Br.	Dužina drške		
52198	140 cm		1



ČETKA
MADE IN EU

Br.	specifikacija		
52119	29 cm		24



ČETKA SA LOPATICOM



Br.	specifikacija		
52168			26



ČETKA SA LOPATICOM



Br.	specifikacija		
52173			26



FESTA
LOPATA

Br.	specifikacija		
52176	22 x 23 cm		24

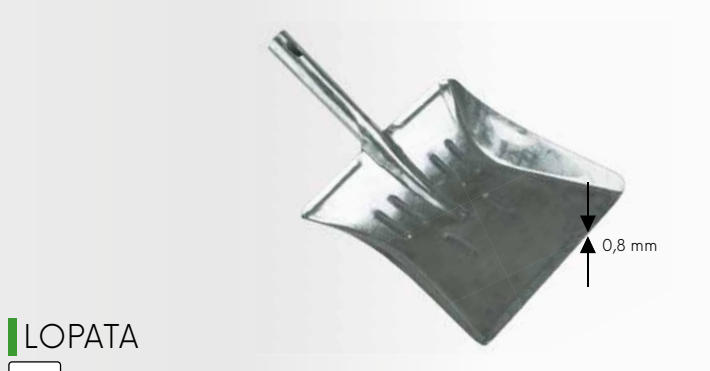

LOPATA



Br.	specifikacija		
52175	22 x 23 cm		50

ČETKA SA NASADOM



Br.	specifikacija	MOQ
52197	30 cm 120 cm Drvena	3



PAJALICA



Br.	specifikacija	Sa navojem	MOQ
52108	30 cm	Sa navojem	25
61172	drška 120 cm	Sa navojem	1



PAJALICA

Br.	specifikacija	Dužina drške	MOQ
61149	37 cm	160 cm	3



PAJALICA

Br.	specifikacija	MOQ
45323	37 cm	16



PAJALICA



Br.	specifikacija	Dužina drške	MOQ
52190	30 cm	150 cm	3
52191	40 cm	150 cm	3
52192	50 cm	150 cm	3
52193	60 cm	150 cm	3
52194	80 cm	150 cm	3



PAJALICA



Br.	specifikacija	MOQ
52101	30 cm	10
52102	40 cm	10
52103	50 cm	10
52104	60 cm	10
52105	80 cm	10



PAJALICA



Br.	specifikacija	Dužina drške	MOQ
52185	40 cm	150 cm	3
52186	50 cm	150 cm	3
52187	60 cm	150 cm	3
52188	70 cm	150 cm	3
52189	80 cm	150 cm	3



PAJALICA



Br.	specifikacija	MOQ
52160	40 cm	10
52161	50 cm	10
52162	60 cm	10
52163	70 cm	10
52164	80 cm	10





PAJALICA



Br.	specifikacija		
52114	28 cm	Sa navojem	1



ČETKA SA NASADOM



Br.	specifikacija	Dužina drške	
52116	28 cm	130 cm	3



ČETKA



Br.	specifikacija		
52113	30 cm	Sa navojem	26
52115	30 cm	Bez navoja	26



ČETKA SA NASADOM



Br.	specifikacija		
52195	30 cm	150 cm Drvena	3
52196	30 cm	130 cm ALU	3



Ø 23 mm

SPAHLA SA GUMOM

Br.	specifikacija		
15886	450 mm	Držalje Ø 23 mm	48
15887	600 mm	Držalje Ø 23 mm	48
15888	750 mm	Držalje Ø 23 mm	32



ČETKA SA NASADOM



Br.	specifikacija		
52109	25 cm	120 cm Drvena	12

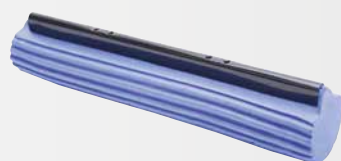

MOP-ZOGER

Br.	specifikacija		
52111	30 cm		1



MOP-ZOGER

Br.	specifikacija		
52110	30 cm		16



LOPATE ZA SNEG

**FESTA**

LOPATA ZA SNEG

Br.	specifikacija	
60006	46 x 34 cm	12
60206	46 x 34 cm, Sastavljeni	1

**FESTA**

LOPATA ZA SNEG

Br.	specifikacija	
60008	50 x 34 cm	12
60208	50 x 34 cm, Sastavljeni	1



LOPATA ZA SNEG



Br.	specifikacija	
60001	48 x 40 cm	10
60201	48 x 40 cm, Sastavljeni	1



LOPATA ZA SNEG

ALU

Br.	specifikacija	
60012	50 x 38 cm	12
60212	50 x 38 cm, Sastavljeni	1



STRUGAČ ZA LED

MOQ
3

Br.	specifikacija	
60022	20 cm	3



STRUGALICA ZA LED

Br.	specifikacija	
60018	15 cm	20
60019	20 cm	24
60020	30 cm	20
61201	drška 130 cm	10



SOL PROTIV ZAMRZAVANJA

Br.	specifikacija	
43300	10 kg	1
43301	25 kg	1



DRŠKA ZA METLE



Br.	specifikacija	
61172	120 cm Drvena sa navojem	1
61192	150 cm Drvena	pro 52195 1
61193	150 cm Drvena	pro 52185 - 94 1
61194	140 cm Drvena sa navojem	1



Ø 22 mm

DRŠKA ZA METLE



Br.	specifikacija		Br.	specifikacija	
61171	1,2 m	1	61175	1,6 m	1
61173	1,4 m	1	61176	1,7 m	1
61174	1,5 m	1	61177	1,8 m	1

DRŠKA ZA METLE



Br.	specifikacija	
52125	130 cm, sa finim navojem	1
52126	130 cm, sa navojem	1

DRŽALO ZA LOPATU I VILE



Br.	specifikacija	
61200	130 cm	10



DRŽALO ZA GRABLJE



system click
ON - OFF

Br.	specifikacija	
45330	161 cm	24
45331	100 cm	24

DRŽALO ZA LOPATU RAVNO



Br.	specifikacija	
61201	130 cm, rovná	10



DRŽALO ZA AŠOV



Br.	specifikacija	
61208	90 cm	10



DRŽALO ZA LOPATU T RAVNO



Br.	specifikacija	
61202	130 cm, ravno	10



DRŽALO ZA FANGLU



Br.	specifikacija	
61215	160 cm	10



DRŽALJE ZA MOTIKU SA PLAST. T RUKOHVATOM



Br.	specifikacija	
61207	100 cm	10



DRŽALO ZA KRAMP



Br.	specifikacija	
61204	95 cm, uska (pro 61120)	10
61205	95 cm	10



DRŽALO ZA MOTIKU



Br.	specifikacija	
61219	120 cm	10



DRŽALO ZA GRABLJE



Br.	specifikacija	
61183	150 cm	10
61184	160 cm	10
61189	170 cm	10
61190	180 cm	10



DRŽALO ZA GRABLJE



Br.	specifikacija	
61195	120 cm	10



DRŽALO ZA GRABLJE



Br.	specifikacija	vhodné pro	
61250	160 cm	45051, 61048	20
61251	160 cm	45052	20
61252	160 cm	45320	20
61253	160 cm	45053	20
61254	160 cm	45054	20
61255	160 cm	45070	20
61256	160 cm	45055	20



PLASTIČNI RUKOHVAT Y ZA DRŽALA

Br.	specifikacija	
61230		10

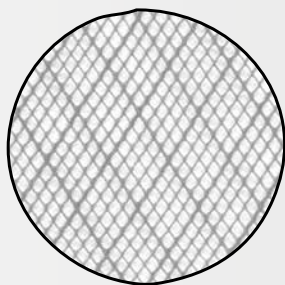

MREŽA PROTIV KOMARACA

Br.	specifikacija	
40100	1 x 25 m - PE beli	1
40120	1,2 x 25 m - PE beli	1

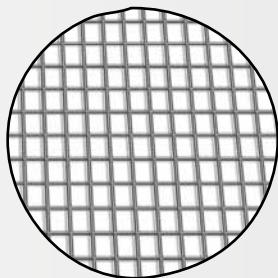

KOMARNIK

ALU Zn

Br.	specifikacija	
42101	1 x 30 m - ALUMINIUM	2
42103	1 x 30 m - Galvanizirana	2

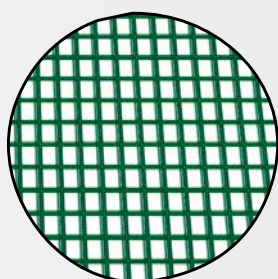

KOMARNIK

Br.	specifikacija	
42102	1 x 30 m - Zeleno lakirana	2

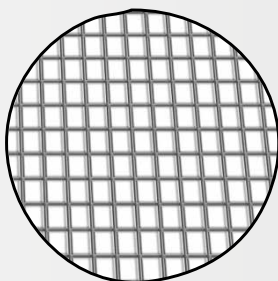

KOMARNIK FIBERGLASS

Br.	specifikacija		
41083	0,8 x 30 m	Beli	6
41103	1 x 30 m	Beli	6
41123	1,2 x 30 m	Beli	6
41153	1,5 x 30 m	Beli	6

Br.	specifikacija		
41082	0,8 x 30 m	Beli-sivi	6
41102	1 x 30 m	Beli-sivi	6
41122	1,2 x 30 m	Beli-sivi	6
41152	1,5 x 30 m	Beli-sivi	6

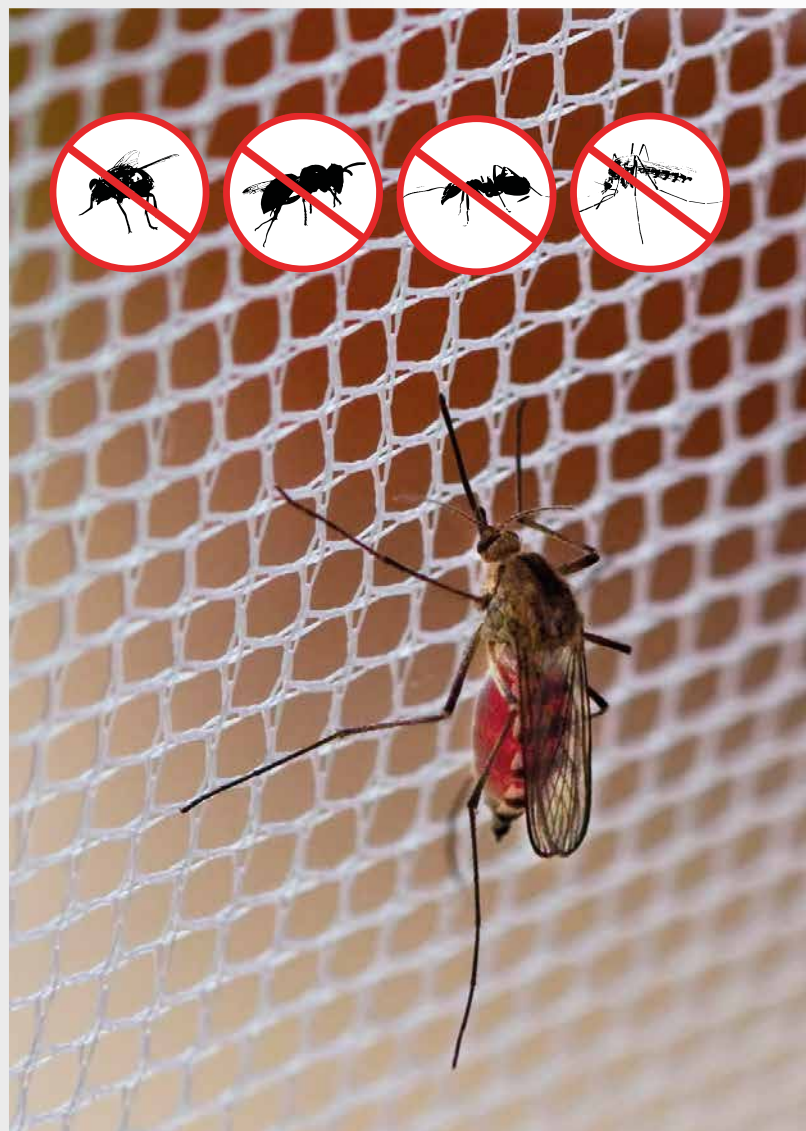

MREŽICE PROTIV KOMARACA

Br.	specifikacija		
41050	0,5 x 30 m	Sivi	6
41080	0,8 x 30 m	Sivi	6
41100	1 x 30 m	Sivi	6
41120	1,2 x 30 m	Sivi	6
41150	1,5 x 30 m	Sivi	6

Br.	specifikacija		
41081	0,8 x 30 m	Crni	6
41101	1 x 30 m	Crni	6
41121	1,2 x 30 m	Crni	6
41151	1,5 x 30 m	Crni	6

NEW



ZAVESNA NA VRATIMA PROTIV INSEKATA MAGNETNI, ANTRACIT



Br.	Specifikacija	
40077	100 x 220 cm	1

ZAVESA

· Promenljiva veličina 60 - 120 cm

Br.	specifikacija		
40075	4 x 35 x 220 cm	Beli	20
40076	4 x 35 x 220 cm	Crni	20



MREŽA PROTIV KOMARACA - BELI



Br.	specifikacija		
40050	150 x 130 cm	5,6 m	10
40052	150 x 180 cm	6,6 m	10
40054	150 x 90 cm	4,8 m	10
40056	220 x 75 cm 2 kom	5,8 m	10



MREŽA PROTIV KOMARACA - SIVI



Br.	specifikacija		
40051	150 x 130 cm	5,6 m	10
40053	150 x 180 cm	6,6 m	10
40055	150 x 90 cm	4,8 m	10



MREŽA PROTIV KOMARACA - CRNI



Br.	specifikacija		
40057	150 x 130 cm	5,6 m	10
40058	150 x 180 cm	6,6 m	10
40059	150 x 90 cm	4,8 m	10



ČIČAK TRAKA

Br.	specifikacija		
40060	9 mm 7 m		1



HEKOMEGON PLETIVO ZN

Zn

Br.	specifikacija	
42150	13 0,7 x 1000 mm - 50 m	1
42151	16 0,7 x 1000 mm - 50 m	1
42152	20 0,7 x 1000 mm - 50 m	1
42153	25 0,8 x 1000 mm - 50 m	1

HEKOMEGON PLETIVO ZN

Zn

Br.	specifikacija	
42155	13 0,7 x 1000 mm - 50 m	1
42156	16 0,7 x 1000 mm - 50 m	1
42157	20 0,7 x 1000 mm - 50 m	1
42158	25 0,8 x 1000 mm - 50 m	1

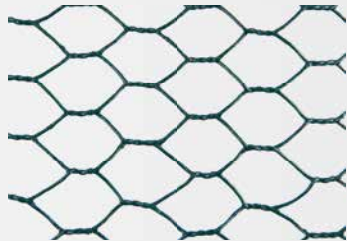

HEKOMEGON PLETIVO PVC

Zn

Br.	specifikacija	
42160	13 1 x 1000 mm - 25 m	1
42161	16 1 x 1000 mm - 25 m	1
42162	20 1 x 1000 mm - 25 m	1
42163	25 1 x 1000 mm - 25 m	1

PLETIVO PLASTIČNI

Br.	Oko	Ø žice	visina	length	
42175	15 x 9 mm	2 mm	40 cm	25 m	1
42176	15 x 9 mm	2 mm	65 cm	25 m	1
42177	15 x 9 mm	2 mm	90 cm	25 m	1
42178	15 x 9 mm	2 mm	120 cm	25 m	1
42179	15 x 9 mm	2 mm	25 cm	25 m	1

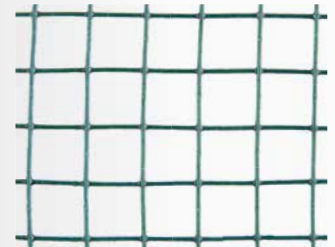
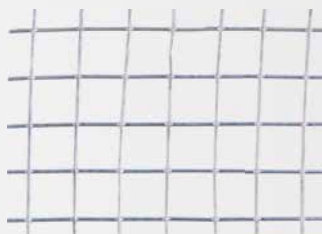

RABIC PUNKTOVAN

Zn

Br.	specifikacija		Br.	specifikacija	
42185	6 0,65 x 1000 mm - 25 m	1	42174	25 1,4 x 1000 mm - 25 m	1
42170	10 0,8 x 100 mm - 25 m	1	42186	13 1,05 x 1000 mm - 25 m	1
42171	13 0,8 x 1000 mm - 25 m	1	42187	25 2,0 x 1000 mm - 25 m	1
42172	16 1,2 x 1000 mm - 25 m	1	42188	50 2,0 x 1000 mm - 25 m	1
42173	19 1,4 x 1000 mm - 25 m	1			

RABIC PUNKTOVAN PVC

Br.	specifikacija	
42180	13 1,2 x 1000 mm - 25 m	1
42181	16 1,2 x 1000 mm - 25 m	1
42182	25 2,3 x 1000 mm - 25 m	1

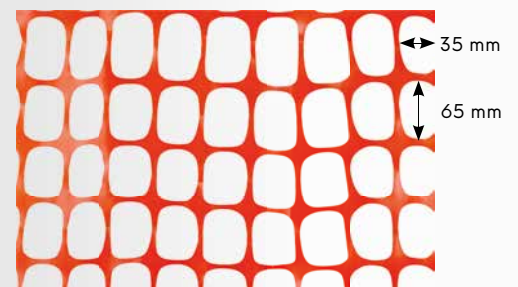

MREŽA PROTIV PTICA



Br.	specifikacija	
45570	2 x 5 m 18 x 18 mm	45
45571	2 x 10 m 18 x 18 mm	28
45572	4 x 5 m 18 x 18 mm	24
45573	4 x 10 m 18 x 18 mm	15

SIGURNOSNA OGRADA

Br.	specifikacija	
42190	1,2 x 50 m HDPE 140g/m ²	1

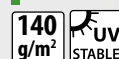

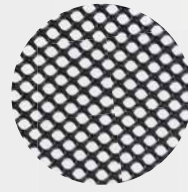

PLETIVO RABICO



Br.	specifikacija	
42312	1 m 50 bm, 16 x 16 mm	1

ZAŠTITNA MREŽA ZA DRVEČE

Sa samozatvaranjem



Br.	specifikacija	
45580	Ø 11 x 80 cm	1



ŽICA ZN



Br.	Ø žice	Dužina žice	
42203	0,6 mm	30 m	50

ŽICA



Br.	Ø žice	Dužina žice	
42207	0,8 mm	50 m	40
42208	0,8 mm	100 m	20
42209	0,9 mm	100 m	20
42240	1,0 mm	50 m	40
42210	1,0 mm	100 m	20
42211	1,2 mm	50 m	40
42212	1,2 mm	100 m	20
42213	1,4 mm	30 m	40
42214	1,4 mm	50 m	20
42217	1,8 mm	30 m	40
42218	1,8 mm	50 m	20

ŽICA



Br.	Ø žice	Dužina žice	
42219	2,0 mm	26 m	20
42220	2,0 mm	52 m	20
42221	2,0 mm	78 m	20
42228	3,15 mm	26 m	10
42229	3,15 mm	52 m	10
42230	3,15 mm	78 m	10



ŽICA ZELENA PVC

Br.	Ø žice	Dužina žice	Površina	
42201	0,6 mm	30 m	PVC	50
42202	0,9 mm	30 m	PVC	50

ŽICA PLASTIČNI

Br.	Ø žice	Dužina žice	
42244	1,4 mm	50 m	20
42248	1,8 mm	50 m	20
42249	2,0 mm	50 m	20

ŽICA PLASTIČNI

Br.	Ø žice	Dužina žice	
42251	2,6 mm	26 m	20
42252	2,6 mm	52 m	20
42253	2,6 mm	78 m	20
42255	3,4 mm	26 m	10
42256	3,4 mm	52 m	10
42257	3,4 mm	78 m	10



BODLJIKAVA ŽICA

Zn			
Br.	Ø žice	Dužina žice	
42260	1,7 mm	50 m	1
42261	1,7 mm	100 m	1

ZATEZAČ ŽICE

INOX			MOQ 50
Br.	specifikacija		
50040	Nerđajući kraj - Zelena	50	
50041	Nerđajući kraj - Crna	50	

ZATEZAČ ŽICE

10x			
Br.	specifikacija		
50042		10	



ZATEZAČ ŽIČANE OGRADE

Zn		
Br.	specifikacija	
50030	Mali Zn presvučen	50
50032	Mali PVC presvučen	50

ZATEZAČ ŽIČANE OGRADE

Zn		
Br.	specifikacija	
50031	Veliki Zn presvučen	50
50033	Veliki PVC presvučen	50



ZATEZAČ ŽIČANE OGRADE LT

Zn		
Br.	specifikacija	
50037	Mali Zn presvučen	50
50038	Mali PVC presvučen	50

ZATEZAČ ZA OGRADE

Br.	specifikacija	
50035	2 t	6
50036	4 t	4

NEW

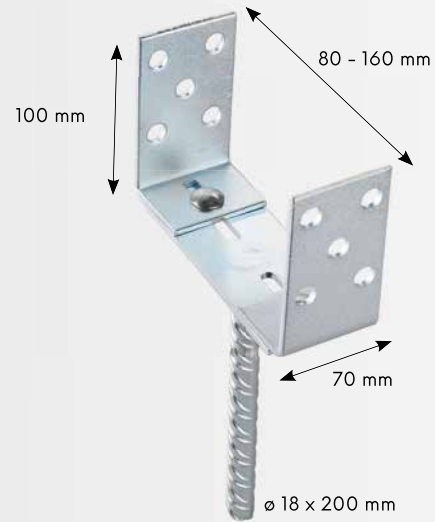
STUBNO SIDRENO
STOPALO PODESIVI

Zn

Br.	Specifikacija	tl.		
55465	80 - 160 x 70 mm	100 mm	4 mm	1



Ø 18 x 200mm

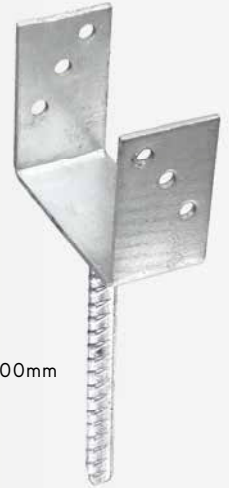

Ø 18 x 200mm

NOSAČ STUBA POCINČANI

Zn

Br.	specifikacija	tl.	
55436	70 x 75 mm	110 mm	4 mm
55437	80 x 90 mm	130 mm	4 mm

NOSAČ STUBA POCINČANI

Zn

Br.	specifikacija	tl.	
55429	70 x 60 mm	100 mm	4 mm
55433	81 x 60 mm	100 mm	4 mm
55430	91 x 60 mm	100 mm	4 mm
55431	101 x 60 mm	100 mm	4 mm
55432	121 x 60 mm	100 mm	4 mm



DRŽAČ STUBA USADNI - POCINKOVANA

Zn

Br.	Ø stopala	Dužina stopala	Debljina materijala	
55400	71 x 71 mm	750 mm	2 mm	1
55401	91 x 91 mm	750 mm	2 mm	1
55406	81 x 81 mm	750 mm	2 mm	1
55402	91 x 91 mm	900 mm	2 mm	1
55403	101 x 101 mm	900 mm	2 mm	1
55404	121 x 121 mm	900 mm	2 mm	1
55405	151 x 151 mm	900 mm	2 mm	1



NOSAČ ZA STUBOVE ČETVRTASTI - POCINKOVANI

Zn

Br.	Ø stopala	Dužina stopala	Debljina materijala	
55420	71 x 71 mm	150 mm	2 mm	1
55425	81 x 81 mm	150 mm	2 mm	1
55421	91 x 91 mm	150 mm	2 mm	1
55422	101 x 101 mm	150 mm	2 mm	1
55423	121 x 121 mm	150 mm	2 mm	1
55424	151 x 151 mm	150 mm	2 mm	1

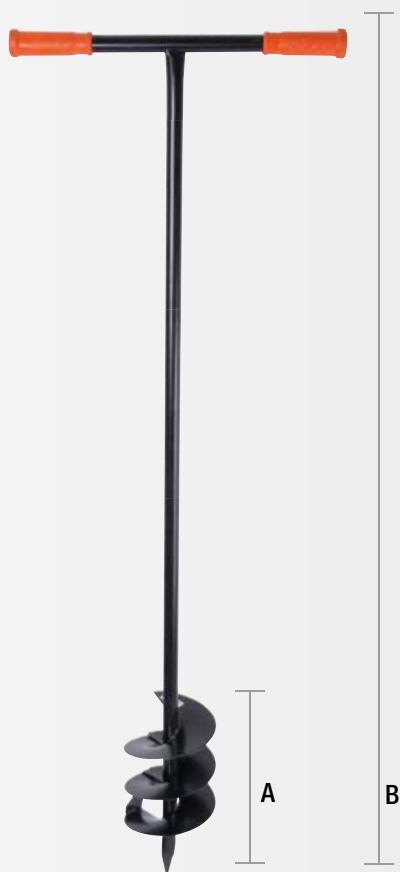

SVRDLO ZA BUŠENJE ZEMLJE

Br.	Ø	A	B	
61299	110 mm	270 mm	1200 mm	1
61300	140 mm	270 mm	1200 mm	1
61301	170 mm	270 mm	1200 mm	1
61302	200 mm	270 mm	1200 mm	1

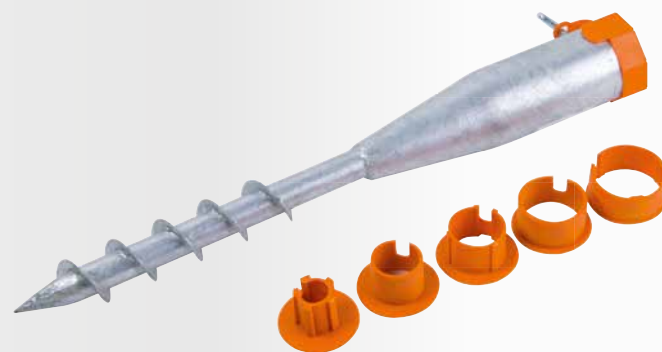

UNIVERZALNI SET ZA PRIČVRŠČIVANJE

· Reduction

- Ø 24 mm
- Ø 35 mm
- Ø 40 mm
- Ø 48 mm
- Ø 55 mm

Zn **6x**

Br.	Ø stopala	Dužina stopala	specifikacija	
55450	60 mm	550 mm	1 kom 5x smanjenje	8

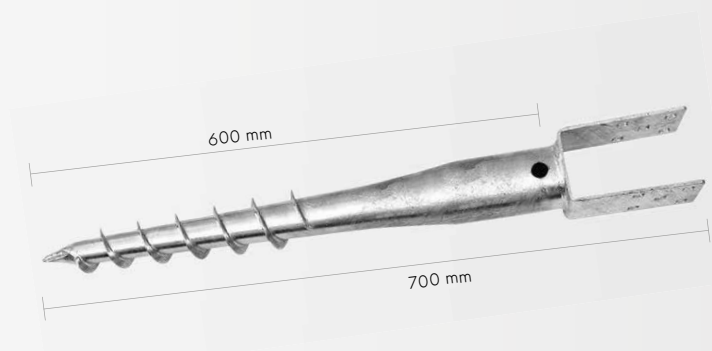

UNIVERZALNI SET ZA PRIČVRŠČIVANJE "U,"

Zn

Br.	Ø stopala	Dužina stopala	Debljina materijala	
55455	71 x 60 mm	100 mm	4 mm	1
55452	81 x 60 mm	100 mm	4 mm	1
55456	90 x 60 mm	100 mm	4 mm	1
55453	101 x 60 mm	100 mm	4 mm	1
55457	110 x 60 mm	100 mm	4 mm	1
55454	121 x 60 mm	100 mm	4 mm	1



PODNOŽJE STUBA SA VIJKOM ZA UGRADNJU

Zn

Br.	Ø stopala	visina stopala	konac	
55460	80 x 80 mm	150 mm	M16	10
55461	100 x 100 mm	150 mm	M16	10
55462	150 x 150 mm	150 mm	M24	10

ZAŠTITNE MREŽE

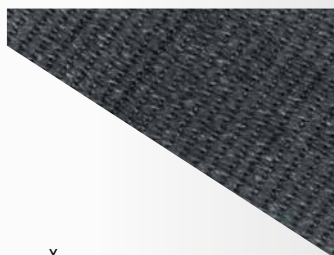
**MREŽA ZAŠTITNA HDPE
150 G/ M² ANTRACIT**

 · Štiti do 85%

Br.	specifikacija	
45496	1 x 10 m	1
45497	1,5 x 10 m	1
45498	1,8 x 10 m	1
45499	2 x 10 m	1

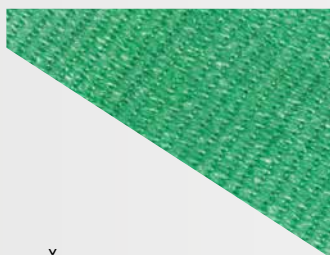
**MREŽA ZAŠTITNA OD SUNCA
HDPE 150 G/ M²**

 · Štiti do 85%

Br.	specifikacija	
45460	1 x 10 m	1
45461	1,5 x 10 m	1
45463	1,8 x 10 m	1
45462	2 x 10 m	1

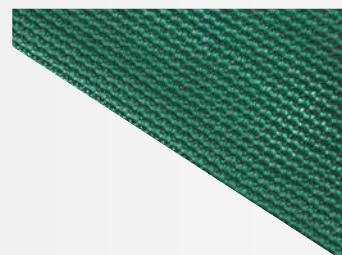

**MREŽA ZAŠTITNA OD SUNCA
HDPE 220 G/ M²**

 · Štiti do 95%

Br.	specifikacija	
45465	1 x 10 m	1
45466	1,5 x 10 m	1
45467	2 x 10 m	1

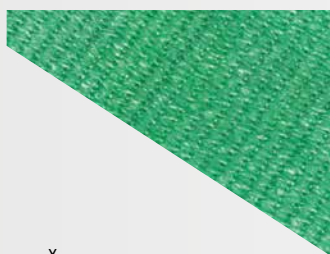

**MREŽA ZAŠTITNA OD
SUNCA HDPE 80 G/ M²**

Br.	specifikacija	
45450	1 x 10 m	1
45451	1,5 x 10 m	1
45453	1,8 x 10 m	1
45452	2 x 10 m	1

**MREŽA ZAŠTITNA OD SUNCA
HDPE 150 G/ M²**

 · Štiti do 85%

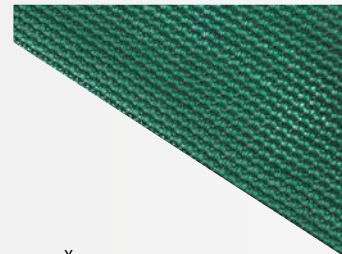
Br.	specifikacija	
45480	1,5 x 50 m	1

**MREŽA ZAŠTITNA OD
SUNCA HDPE 220 G/ M²**

 · Štiti do 95%

Br.	specifikacija	
45485	1,5 x 50 m	1

NEW

VEZICE

 · EN 50146
 · nylon

Br.	Specifikacija	
23875	120 mm 4,8 mm	1

KARIKA NA TKANINI ZA ZATAMNENJE

Br.	specifikacija	
45470		1



PRIBOR ZA ROŠTILJ



PRIBOR ZA ROŠTILJ SET

INOX 18x

Br. specifikacija
43077



6



PRIBOR ZA ROŠTILJ SET

INOX 3x

Br. specifikacija
43071 380 mm



16



PRIBOR ZA ROŠTILJ

INOX

Br. specifikacija
43072 360 mm



25



TACNA AL.ZA ROŠTILJ

4x

Br. specifikacija
43050 300 x 200 mm

50

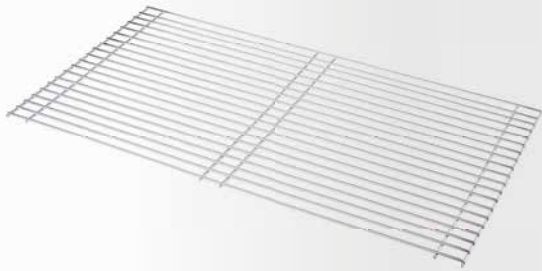

REŠETKA ZA ROŠTILJ

Br.	specifikacija	
43058	58 x 30 mm	20
43060	60 x 40 mm	20
43068	68 x 40 mm	16

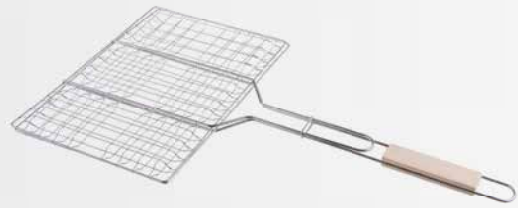

REŠETKA ZA GRIL

Br.	specifikacija	
43084	330 x 290 mm	50

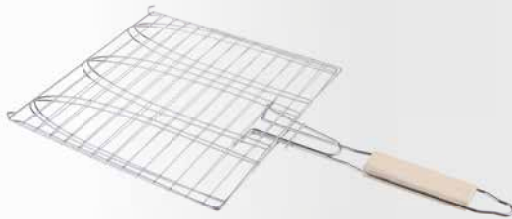

ROŠTILJ ZA RIBE

Br.	specifikacija	
43082	280 x 276 mm	50

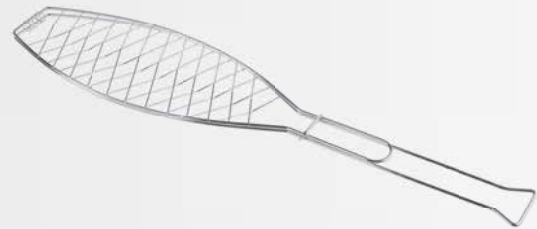

REŠETKA ZA PEČENJE RIBE

Br.	specifikacija	
43083	360 x 130 mm	12

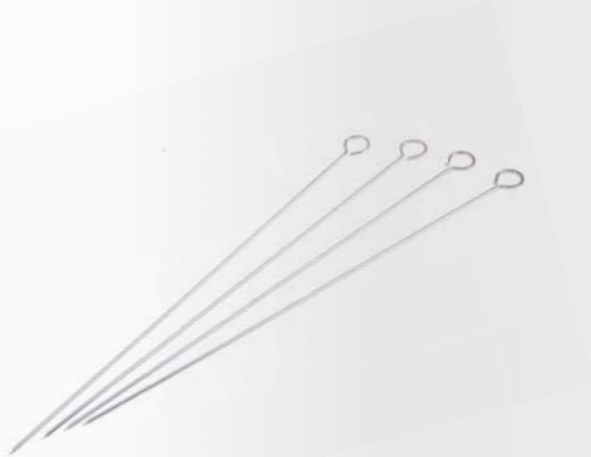

ŠTAPICI METALNI ZA RAŽNJIČE

Br.	specifikacija	
43086	Ø 3 x 380 mm	80



VILJUŠKA ZA ROŠTILJ

· S higijenskim atestom

Br.	specifikacija	
43097	100 cm	100



MOTOR ZA RAŽANJ 230V



Br. specifikacija
43090



24



MOTOR ZA RAŽANJ

· battery type D



Br. specifikacija
43089

48



ČETKA ZA ROŠTILJ 2 V 1

Br. specifikacija
43098 30 cm

10



ČETKA ZA ROŠTILJ 3V1

Br. specifikacija
43099

40



MEH ZA ROŠTILJ

Br. specifikacija
43087



1



400

KATANCI



404

POSTANSKI SANDUCICI,
SEFOVI

406

ZATEZACI



409

KANAP



411

PISTOLJ ZA PLASTIKU



413

DRZAČ STAKLA



415

SAJLA ZA KANALIZACIJU



417

PUMPICA ZA
PODMAZIVANJE, MIŠOLOVKA

418

LED LAMPE



421

PAPER STAND



422

OZAP SU5



426

KUBALA GRAĐEVINSKI ALAT

GVOŽDJARSKA OPREMA I OSTALI

398 - 431



KATANCI I BRAVE

**FESTA**SEF
SA ELEKTRONSKOM BRAVOM

- Tip brave: elektronska, mehanička
- Bezbedonosni ključ
- Dimenzije 350k250k250mm
- Težina 10 kg



Br.	Specifikacija
23270	

**FESTA**

UMETAK ZA BRAVU

Br.	Specifikacija
23001	65 mm · 175 g

10



UMETAK ZA BRAVU PUNKTOVAN NIKEL

Br.	Specifikacija
23000	65 mm · 75 g

15



FESTA

KATANAC



Br.	Specifikacija	
23261	25 mm	6
23262	32 mm	12
23263	38 mm	6



FESTA

KATANAC PRODUZENI



Br.	Specifikacija	
23211	25 mm	12
23212	32 mm	12
23213	38 mm	6



FESTA

KATANAC MS



Br.	Specifikacija	
23310	30 mm	10
23311	40 mm	10
23312	50 mm	6



FESTA

KATANAC MS



Br.	Specifikacija	
23125	25 mm	12
23130	30 mm	12
23135	35 mm	12



FESTA

KATANAC SIGURNOSNI



Br.	Specifikacija	
23274	60 mm	6
23275	70 mm	12



KATANAC ČELIČNI



Br.	Specifikacija	
23220	25 mm	6
23225	30 mm	6
23232	32 mm	6



KATANAC MS



Br.	Specifikacija		Br.	Specifikacija	
23020	20 mm	12	23040	40 mm	12
23025	25 mm	12	23050	50 mm	12
23030	30 mm	12	23060	60 mm	12
23035	35 mm	12			

KATANAC MS PRODUŽENI



Br.	Specifikacija	
23070	40 mm	12



KATANAC ČELIČNI



Br.	Specifikacija	
23010	50 mm	6

KATANAC OTPORAN NA VODU



Br.	Specifikacija	
23005	40 mm	6
23006	50 mm	6

FESTA

KATANAC ZA BICIKLE



Br.	Specifikacija	
23288	120 cm x Ø 10 mm	1

FESTA

KATANAC ZA BICIKLE



Br.	Specifikacija	
23287	65 cm x Ø 10 mm	1



FESTA

KATANAC ZA BICIKLE



Br.	Specifikacija	
23290	120 cm x Ø 8 mm	1
23291	150 cm x Ø 8 mm	20
23292	180 cm x Ø 8 mm	1



KATANAC ZA BICIKLE



Br.	Specifikacija	
23297	180 cm x Ø 8 mm	25



KATANAC ZA BICIKLE



Br.	Specifikacija	
23282	55 cm x Ø 8 mm	50
23284	65 cm x Ø 8 mm	50



KATANAC SA ŠIFROM

Br.	
23281	20



FESTA

PLASTICNI PRIVESAK

100x

Jak krug

Br.	
23391	50



PLASTICNI PRIVESAK

100x

Br.	
23390	1



REZA ZA KATANAC

Br.	Specifikacija	
51514	100 mm	25
51515	120 mm	25
51516	140 mm	25
51517	160 mm	25



REZA

Br.	Specifikacija	
51510	100 mm	12
51511	120 mm	12
51512	140 mm	12
51513	160 mm	12



POŠTANSKI SANDUČIĆI I
KASE



KUTIJA ZA KLJUČEVE



Br.	Specifikacija	
70140	250 x 180 x 80 mm - za 48 ključeva	12
70141	300 x 230 x 90 mm - za 90 ključeva	8



BLAGAJNA



Br.	Širina	Dubina	Visina	
70120	125 mm	95 mm	60 mm	1



BLAGAJNA



Br.	Širina	Dubina	Visina	
70121	152 mm	118 mm	80 mm	36



BLAGAJNA



Br.	Širina	Dubina	Visina	
70122	200 mm	160 mm	90 mm	20



BLAGAJNA



Br.	Širina	Dubina	Visina	
70123	250 mm	180 mm	90 mm	16



BLAGAJNA



Br.	Širina	Dubina	Visina	
70124	300 mm	240 mm	90 mm	10



BLAGAJNA



Br.	Širina	Dubina	Visina	
70125	370 mm	280 mm	90 mm	8



POŠTANSKO SANDUČE



Br.	Boja	Širina	Dubina	Visina	
70101	Belo	290 mm	360 mm	105 mm	5
70100	Smeđa	290 mm	360 mm	105 mm	5



POŠTANSKO SANDUČE



Br.	Boja	Širina	Dubina	Visina	
70102	Belo	310 mm	260 mm	90 mm	10
70103	Smeđa	310 mm	260 mm	90 mm	10



POŠTANSKO SANDUČE



Br.	Boja	Širina	Visina	Dubina	
70104	Belo	310 mm	360 mm	90 mm	6
70105	Smeđa	310 mm	360 mm	90 mm	5



POŠTANSKO SANDUČE



Br.	Boja	Širina	Dubina	Visina	
70108	Belo	370 mm	134 mm	364 mm	5



POŠTANSKO SANDUČE



Br.	Boja	Širina	Dubina	Visina	
70107	INOX	360 mm	100 mm	520 mm	6



POŠTANSKO SANDUČE



Br.	Boja	Širina	Dubina	Visina	
70106	INOX	360 mm	100 mm	360 mm	5



POŠTANSKO SANDUČE



Br.	Boja	Širina	Dubina	Visina	
70109	INOX	310 mm	90 mm	260 mm	6



POŠTANSKO SANDUČE



Br.	Boja	Širina	Dubina	Visina	
70110	INOX	310 mm	90 mm	360 mm	6



ZATEZAČI SA KUKAMA – ŠPANERI



FESTA
ZATEZAČ UNIV. SA KUKAMA



2x



Br.	Širina	Dužina	kapacitet	Kom	
51070	18 mm	2 m	100 kg	2	12



FESTA
ZATEZAČ UNIV. SA KUKAMA



Br.	Širina	Dužina	kapacitet	Kom	
51071	25 mm	3,5 m	300 kg	1	8



FESTA
ZATEZAČ UNIV. SA KUKAMA



Br.	Širina	Dužina	kapacitet	Kom	
51072	35 mm	4 m	500 kg	1	6



FESTA
ZATEZAČ UNIV. SA KUKAMA



Br.	Širina	Dužina	kapacitet	Kom	
51040	25 mm	6 m	1000 kg	1	1
51041	35 mm	8 m	2000 kg	1	1
51042	35 mm	8 m	3000 kg	1	1
51043	50 mm	10 m	5000 kg	1	1



FESTA
ZATEZAČ UNIV. SA KUKAMA



2x



Br.	Širina	Dužina	kapacitet	Kom	
51060	25 mm	5 m	750 kg	2	5



FESTA
ZATEZAČ UNIV. SA KUKAMA



Br.	Širina	Dužina	kapacitet	Kom	
51065	50 mm	10 m	960 kg	1	6



FESTA
ZATEZAČ UNIV. SA KUKAMA



Br.	Širina	Dužina	kapacitet	Kom	
51026	75 mm	5 m	3000 kg	1	4

NEW

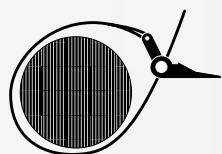

FESTA

ZATEZAČ UNIV.



Br.	Širina	Dužina	kapacitet	Kom	
51032	25 mm	5 m	500 kg	1	6



FESTA

ZATEZAČ UNIV. SA KUKAMA



Br.	Širina	Dužina	kapacitet	Kom	
51017	50 mm	6 m	480 kg	2	5
51018	50 mm	6 m	480 kg	1	10



ZATEZAČ UNIV. SA KUKAMA

Br.	Širina	Dužina	Specifikacija	
51022	25 mm	5 m	Kuke	40
51023	50 mm	5 m	Kuke	12



FESTA

ZATEZAČ UNIV.

PE

Omekšan EVA jastučić

Br.	Širina	Dužina	Kom	
51046	38 mm	4 m	1	20



ZATEZAČ UNIV. SA KUKAMA

Br.	Širina	Dužina	Specifikacija	
51030	50 mm	6 m	Kuke	20
51034	50 mm	8 m	Kuke	10



ZATEZAČ UNIV.

2x

Br.	Širina	Dužina	Kom	
51020	25 mm	2,5 m	2	100



ZATEZAČ UNIV.

PE

Br.	Širina	Dužina	Kom	
51045	25 mm	4 m	1	50



GUMENI ZATEZAČ

2x

Br.	Dužina	Ø	Kom	
51013	1,2 m	8 mm	2	1





GUMENI ZATEZAČ

2x

Br.	Dužina	Kom	
51008	1 m	2	25



25



GUMENI ZATEZAČ



Br.	Dužina	Ø	Kom	
51009	1 m	10 mm	1	25

25



SET ZATEZAČA

8x

- 2 x 0,4 m
- 2 x 0,6 m
- 1 x 0,8 m
- 1 x 1,0 m

Br.	Dužina	Ø	Kom	
51011	1 m	8 mm	8	10



10



GUMENI ZATEZAČ

2x



Br.	Dužina	Ø	Kom	
51001	80 cm	10 mm	2	50
51002	100 cm	10 mm	2	50
51003	150 cm	10 mm	2	50
51004	200 cm	10 mm	2	50

50



GUMENI ZATEZAČ

2x

Br.	Dužina	Ø	Kom	
51007	1 m	8 mm	2	25



25



GUMENI ZATEZAČ

Br.	Dužina	Ø	Specifikacija	
51010	80 cm	8 mm	8 kuka	50

50



GUMENI MREŽA

Br.	Dužina	Širina	
51015	80 cm	120 cm	20



20



GUMIRANO UŽE



Br.	Dužina	Ø	
51036	20 m	8 mm	10
51037	20 m	10 mm	6

10

6



KUKE

20x

Br.	Dužina	
51038	8 mm	30



ALU-KUKA

ALU

MOQ
2

Br.	Ø	Dužina	
51187	5 mm	50 mm	2
51200	6 mm	60 mm	2
51202	7 mm	70 mm	2

Br.	Ø	Dužina	
51201	8 mm	80 mm	2
51203	10 mm	100 mm	2



NAJLONSKO UŽE

Br.	Dužina	Ø	
51055	80 m	1,5 mm	50
51056	50 m	2 mm	50
51057	20 m	4 mm	50



PP KANAP

Br.	Težina	
50905	80 g	80
50906	100 g	100
50907	200 g	50



JUTANI KANAP

Br.	Težina	
50900	80 g (61 m)	1
50901	100 g (76 m)	1
50902	200 g (153 m)	1



UŽE



Br.	Dužina	Ø	
50915	5 m	8 mm	1
50916	25 m	8 mm	1
50917	25 m	10 mm	1
50918	25 m	12 mm	1
50919	25 m	14 mm	1



NAJLONSKO UŽE

Br.	Dužina	Ø	
51050	50 m	8 mm	10
51051	50 m	10 mm	4



PP KANAP

Br.	Težina	
50909	500 g (250 m)	1
50910	1000 g (500 m)	1
50911	5000 g (2500 m)	1



KANAP



Br.	Dužina	Ø	
50920	50 m	1 mm	80

NEW



VEZICE

· EN 50146
· nylon

50x

Br.	Specifikacija		
23875	120 mm	4,8 mm	1



VEZICE

100x

· EN 50146
· Найлон

Br.	Dužina	Širina	
23880	100 mm	2,5 mm	1
23882	150 mm	2,5 mm	1
23884	200 mm	3,6 mm	1



Ø 15 - 32 mm

VEZICE SA DRŠKOM

10x

UV
STABLE

Br.	Dužina	Širina	
23865	160 mm	7,5 mm	1



VEZICE, BIJELE

50x

· EN 50146
· Найлон

Br.	Dužina	Širina	
23850	120 mm	2,5 mm	1
23854	200 mm	3,6 mm	1
23856	250 mm	3,6 mm	1
23858	250 mm	4,8 mm	1
23860	300 mm	4,8 mm	1
23864	400 mm	4,8 mm	1
23866	500 mm	4,8 mm	1
23868	400 mm	7,6 mm	1
23870	500 mm	7,6 mm	1



FESTA

VELKRO TRAKA 3 KOM

3x

Br.	Širina	Dužina	
37295	20 mm	150 mm	1
37296	20 mm	200 mm	1
37297	20 mm	250 mm	1



VEZICE, CRNE

50x

· EN 50146
· Найлон

Br.	Dužina	Širina	
23810	120 mm	2,5 mm	1
23814	200 mm	3,6 mm	1
23816	250 mm	3,6 mm	1
23818	250 mm	4,8 mm	1
23820	300 mm	4,8 mm	1
23824	400 mm	4,8 mm	1
23826	500 mm	4,8 mm	1
23828	400 mm	7,6 mm	1
23830	500 mm	7,6 mm	1



VELKRO TRAKA

Br.	Specifikacija		
45471	12 mm x 5 m		1





FESTA

PISTOLJ ZA PLASTIKU



Br.	Specifikacija		
89975	80 W 230 V	Ø municija 11,2 mm	20



PISTOLJ ZA PLASTIKU



Br.	Specifikacija		
89973	60 W 230 V	Ø municija 11,2 mm	20



PISTOLJ ZA PLASTIKU



Br.	Specifikacija		
89970	15 W 230 V	Ø municija 7,2 mm	25



MUNICIJA ZA PISTOLJ ZA PLASTIKU

Br.	Ø	Dužina	Kom	
89985	11,2 mm	200 mm	10	50
89987	11,2 mm	200 mm	1 kg	25



MUNICIJA ZA PISTOLJ ZA PLASTIKU

Br.	Ø	Dužina	Kom	
89980	7,2 mm	100 mm	12	100
89988	7,2 mm	100 mm	1 kg	25



MUNICIJA ZA PISTOLJ ZA PLASTIKU

Br.	Ø	Dužina	Kom	
89990	11,2 mm	200 mm	10	50



MUNICIJA ZA PISTOLJ ZA PLASTIKU

Br.	Ø	Dužina	Kom	
89989	7,2 mm	100 mm	12	100

**FESTA**

TOPLI VAZDUŠNI PIŠTOLJ SA REGULACIJOM

napětí / frekvence	230V / 50Hz
příkon	2000W
poloha spínače	0 - I (350°C) - II (600°C)
příslušenství	nerezové nástavce - 4 Kom



Br. Specifikacija
35320 2000 W

5

FESTA

TOPLI VAZDUŠNI PIŠTOLJ SA REGULACIJOM TEMPERATURE

napětí / frekvence	230V / 50Hz
příkon	2000W
poloha spínače	0 - I (50°C) - II (50 - 600°C)
proud vzduchu	250 - 500 l/min.
příslušenství	nerezové nástavce - 4 Kom
	Digitalni ekran



Br. Specifikacija
35322 2000 W

5

NEW**FESTA**

DRŽAČ PLOČICA SA INDIKATOROM VAKUUMA

grube i strukturirane površine

Br. Specifikacija
36325 max. 220 kg



1



FESTA

DRZAČ STAKLA

Položaj	Nosivost
Horizontalni položaj	50 kg
Vertikalni položaj	50 kg

ALU

Br.	Specifikacija
36314	Jednodelni



20

DRZAČ STAKLA

Br.	Specifikacija
36305	Jednodelni



60



FESTA

DRZAČ STAKLA

Položaj	Nosivost
Horizontalni položaj	80 kg
Vertikalni položaj	100 kg

ALU

Br.	Specifikacija
36313	Dupli



20

DRZAČ STAKLA

Br.	Specifikacija
36306	Dupli



20



FESTA

DRZAČ STAKLA

Položaj	Nosivost
Horizontalni položaj	120 kg
Vertikalni položaj	150 kg

ALU

Br.	Specifikacija
36318	Triple



10

DRZAČ STAKLA

Položaj	Nosivost
Horizontalni položaj	80 kg
Vertikalni položaj	100 kg

Br.	Specifikacija
36319	Triple



10



VAGA RUČNA

Br.	Nosivost
24260	50 kg



10

VAGA RUČNA

Br.	Nosivost	Učestalost
24212	12,5 kg	48
24225	25 kg	6
24250	50 kg	6
24255	100 kg	6
24258	150 kg	6



PINCETA SA LED SVETLOM



Br.	Specifikacija
50005	95 mm



8



SET PINCETA INOX



Br.	Specifikacija
50004	



1

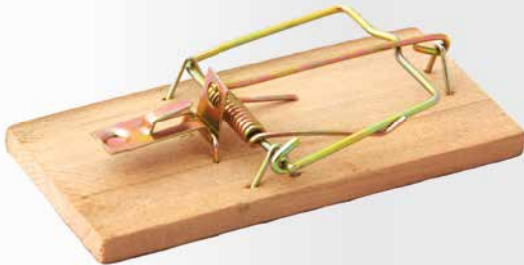

MIŠOLOVKA

2x

Br.	Specifikacija
70221	90 x 45 mm Drvena



1



MIŠOLOVKA

2x

Br.	Specifikacija
70220	97 x 47 mm Plastična



48

NEW



KLJUČ ZA ODZRAČIVANJE RADIJATORA SA KONTEJNEROM



Br.	Specifikacija
17459	50 ml

1



SAJLA ZA KANALIZACIJU

· mogućnost upotrebe sa bušilicom

Br.	Dužina	Ø
50014	6 m	6 mm



6



SAJLA ZA KANALIZACIJU

Br.	Dužina	Ø
50009	3 m	5 mm



40

SAJLA ZA KANALIZACIJU

Br.	Dužina	Ø
50010	3 m	10
50011	5 m	5
50012	10 m	3
50013	15 m	4



PUMPA ZA ČIŠĆENJE SLIVNIKA

Br.	Dužina	Ø
50015	385 mm	65 mm



30



ELEKTRICARSKA VODJICA ZA KABLOVE

Br.	Dužina	Ø
51181	8 m	5 mm
51182	10 m	5 mm



25

25

NEW

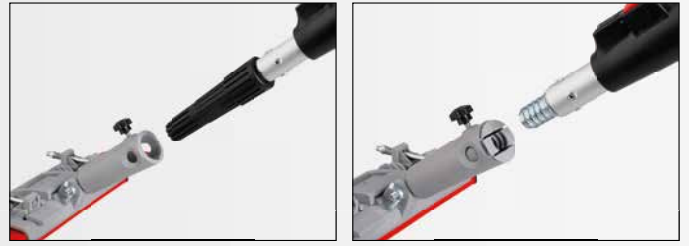

FESTA®

ŠTAP TELESKOPSKI

konac za 31610, 34203

Br.	Specifikacija
52011	88 - 140 cm



ŠTAP TELESKOPSKI

ALU

Br.	Dužina		
52010	120 cm	ALU	50
52012	240 cm	ALU	25



ŠTAP TELESKOPSKI

Br.	Dužina		
52020	300 cm	Čelik	10



ŠTAP TELESKOPSKI

Br.	Dužina		
52030	240 cm	fiberglass	6

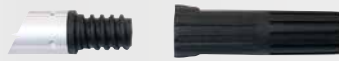

ALAT ZA SAKUPLJANJE SMEĆA

Rotirajuće za 90 °

Br.	Dužina
61235	81 cm



ALAT ZA SAKUPLJANJE SMEĆA

Max. 4 kg

Br.
61236





PUMPICA ZA PODMAZIVANJE

Br.	Specifikacija	
50020	300 ml	10

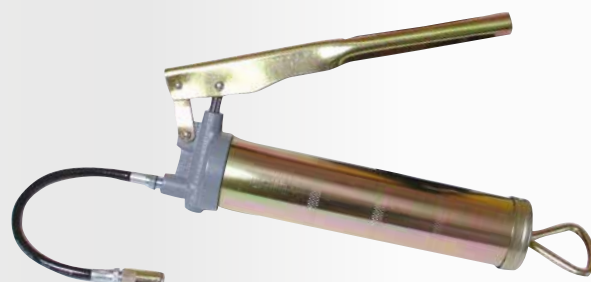

PUMPA ZA TOVATNU MAST

- bulk loading
- cartridge loading
- plnění čerpadlem

Br.	Specifikacija	
50022	400 ml	20



PUMPA ZA ISTAKANJE

Br.	Specifikacija	
50017		10



KANTICA ZA ULJE PVC

Br.	Specifikacija	
50019	90 ml	1



KLJUČ ZA SKIDANJE FILTERA

Br.	Specifikacija	
50021	60 x 140 mm	6



LEVAK

Br.	Specifikacija	
50025	60 x 140 mm	50



PRENOSNO CREVO SA SAMOUSISAVAJUĆIM VENTILOM

Br.	Dužina	Ø	
50026	180 cm	15 mm	24

TELA ZA OSVETLJENJE



FESTA

LED LAMPA



Br.	Specifikacija	
37645	200 mm	3 x AAA

MOQ
12



FESTA

NAGLAVNA LED LAMPA

Težina	42 g
izvor osvetljenja	1 x 1 W white LED + 2x red LED
Baterije	3 x AAA
Dimenzije	40 x 59 x 32 mm
Radni sati	45 h
Jačina osvetljenja	120 lumen
Doseg	60 m (100% battery)
Režimi svíceni	4



5 positions



Br.	Specifikacija
37641	2 kinds of light, white and red



FESTA

NAGLAVNA LED LAMPA



Br.	Specifikacija
37640	120 lumen + red light





FESTA
LED LAMPA

LED light 3x AA

Br. 37650

12



FESTA
LED LAMPA

ALU LED light 2xAA 80 lumen

Br. 37630 Specifikacija 185 mm 2 x AA

20

LED LAMPA

Perfom	0,6 W
boja svetlosti	700k
Baterije	2xD
Težina	138g
Doseg	30 m
osvetljenje	50 lm



ALU LED light 2xAA 80 lumen

Br. 37621 Specifikacija 185 mm

6



KONZOLA BELA

 MOQ
2

Br.	Specifikacija	
81100	100 x 75 mm	24
81101	125 x 100 mm	24
81102	150 x 125 mm	24
81103	200 x 150 mm	24
81104	250 x 200 mm	24
81105	300 x 250 mm	24
81106	350 x 300 mm	24



DRŽAČ (NOGA) REGALA

Br.	Specifikacija	
81053	50 cm	10
81054	80 cm	10
81056	150 cm	10
81057	200 cm	10



KONZOLA

Br.	Specifikacija	
81070	10 cm	10
81071	15 cm	10
81072	20 cm	10
81074	30 cm	10
81075	35 cm	10
81077	50 cm	10



PAPER STAND FESTA

Br. 81602 Specifikacija 60 x 40 x 175 cm - ENG



PAPER STAND FESTA POWER TOOLS

Br. 81603 Specifikacija 60 x 40 x 175 cm



PAPER STAND FOR LEVELING SYSTEMS

Br. 37179 Specifikacija 60 x 40 x 175 cm - ENG



PRODAJNE STALAŽE SU-5

POZOVITE NAS DA VAM INSTALIRAMO STALAŽNI
SISTEM

POLICA FESTA

Br.	Specifikacija	
81011	Stalaž FESTA CZ 200 x 100 cm	1
81011A	Stalaž 81011 + nalepnica AQUATIC	1
81011F	Stalaž 81011 + nalepnica FESTA CZ	1
81011G	Stalaž 81011 + nalepnica FESTA GB	1
81011H	Stalaž 81011 + nalepnica FESTA SK	1
81011R	Stalaž 81011 + nalepnica ROSA	1
81012	Polica CZ Dubina 40 cm	8
81013	Kukica 10 cm	10
81014	Kukica 16 cm	10
81015	Kukica 20 cm	10
81035	Kukica 20 cm	10
81016	Kukica 30 cm	10
81036	Kukica 30 cm	10
81022	wire basket - big, 50 cm	1
81023	wire basket - small, 40 cm	1
81024	partition - big, 50 cm	1
81025	partition - small, 40 cm	1



PRODAJNE STALAŽE SU-5



POZOVITE NAS DA VAM INSTALIRAMO STALAŽNI
SISTEM

Br.	Specifikacija	
81200	Stožac 40/2400 mm učvršćen	1
81201	Stožac 80/1108 mm	1
81202	Stožac 80/1208 mm	1
81203	Stožac 80/1408 mm	1
81204	Stožac 80/1608 mm	1
81205	Stožac 80/1808 mm	1
81206	Stožac 80/2000 mm	1
81207	Stožac 80/2108 mm	1
81208	Stožac 80/2208 mm	1
81209	Stožac 80/2308 mm	1
81210	Stožac 80/2408 mm	1
81211	Stožac 80/2600 mm	1
81212	Stožac 60/1000 mm	1
81213	Stožac 60/1208 mm	1
81214	Stožac 60/1408 mm	1
81215	Stožac 60/1608 mm	1
81216	Stožac 60/1808 mm	1
81217	Stožac 60/2108 mm	1
81218	Stožac 60/2208 mm	1
81225	Stožac 30/2108 mm prednji	1
81489	Stožac 60/2000 mm	1
81219	Nastavak stošca 80x30/100mm	1
81220	Nastavak stošca 80x30/400 mm	1
81221	Nastavak stošca 80x30/600 mm	1
81222	Nastavak stošca 60x30/400 mm	1
81223	Ugaoni stožac 90° 2100mm	1
81224	Ugaoni stožac 90° 2200mm	1
81226	Oslonac 80	1
81227	Oslonac 60	1
81228	Veza korpe sa policom 80	1
81229	Letva za učvršćenje	1
81230	Kuka za učvršćenje	1
81231	Slabo učvršćenje	1
81232	Učvršćenje vrhom	1
81233	Punjenje 400	1
81234	Punjenje 500	1
81235	Punjenje 600	1
81236	Punjenje 700	1
81237	Punjenje 800	1
81238	Niska konzola 200	1
81239	Niska konzola 300	1
81240	Niska konzola 400	1
81241	Niska konzola 500	1
81242	Visoka konzola 400	1
81243	Visoka konzola 500	1
81244	Visoka konzola 600	1
81245	Visoka konzola 700	1
81246	Niska konzola 300 dupla	1
81247	Niska konzola 400 dupla	1
81248	Niska konzola 500 dupla	1
81251	Konzola RR 80	1
81249	Visoka konzola dupla 500 sanduka	1
81250	Nosač visokog sanduka 400/2000	1
81252	Pregrada police sa udubljenjem	1
81253	Niska pregrada 300	1
81254	Niska pregrada 400	1
81255	Niska pregrada 500	1
81256	Niska pregrada 300 staklo	1
81257	Niska pregrada 400 staklo	1
81258	Niska pregrada 500 staklo	1
81259	Visoka pregrada 300 staklo	1
81262	Visoka pregrada 300 pleKomi-staklo	1
81263	Visoka pregrada 400 pleKomi-staklo	1
81264	Visoka pregrada 500 pleKomi-staklo	1
81260	Visoka pregrada 400 staklo	1
81261	Visoka pregrada 500 staklo	1
81265	Bočna Str. visokog sanduka 400/2000	1
81266	Bočne strane poklopca RR 80	1
81267	Bočne strane spremnika 500mm	1
81268	Bočne strane sanduka 500	1
81269	Gornji nosač 500 sanduka	1
81271	Bočne strane niske police 300 plastika	1
81272	Bočne strane niske police 400 plastika	1
81273	Bočne strane niske police 500 plastika	1
81274	Bočne strane visoke staklo 300/250	1
81275	Osigurač bočnih strana	1
81276	Bočne strane visoke staklo 500/250	1
81277	Bočne strane visoke police 400	1
81278	Bočne strane visoke police 500	1
81270	Nosač poklopca RR 80	1
81279	Nosač poklopca	1
81280	Bočne strane poklopca leve	1
81281	Bočne strane poklopca desne	1
81282	Krak za vešanje	1
81284	Krak dupla 400/10	1
81285	Krak dupla 300/8	1
81286	Krak 350	1
81287	Krak 500	1
81288	Krak 250	1
81289	Vešanje dupla 100	1
81290	Vešanje dupla 200	1
81291	Vešanje dupla 300	1
81292	Vešanje 130 V	1

Br.	Specifikacija	
81293	Vešanje 100	1
81294	Vešanje 200	1
81295	Vešanje 300	1
81296	Kuka sa šipkom 200	1
81297	Kuka sa šipkom 300	1
81298	Brava za sanduka	1
81299	Pregrada žičane 360mm visoka	1
81300	Pregrada žičane 460 mm visoka	1
81301	Pregrada žičane 560 mm visoka	1
81302	Pregrada žičane 560 mm niska	1
81303	Konzola 300 dupla L	1
81304	Konzola 300 dupla P	1
81305	Konzola 400 dupla L	1
81306	Konzola 400 dupla P	1
81307	Konzola 500 dupla L	1
81308	Konzola 500 dupla P	1
81309	Polica polukrug 300	1
81310	Polica polukrug 400	1
81311	Polica polukrug 500	1
81312	Podnožje polukrug 500	1
81313	Čelni podnožje polukrug 500	1
81314	Držač trake za cene 300 polukrug	1
81315	Držač trake za cene 400 polukrug	1
81316	Držač trake za cene 500 polukrug	1
81317	Polica polukrug 600	1
81318	Podnožje polukrug 600	1
81319	Čelni podnožje polukrug 600	1
81320	Trake za cene P 7,5x5 cm	1
81321	Trake za cene P 2,6x3,2 cm	1
81322	Trake za cene P 5,0x4,0 cm	1
81323	Polica šupljikavi 500/1000	1
81324	Vežnik stožer 80, modul 1	1
81325	Zadnji panel 10x100cm	1
81326	Zadnji panel 20x100cm	1
81327	Zadnji panel 40x100cm	1
81328	Zadnji panel šupljikavi 20x100 cm EUR	1
81329	Zadnji panel šupljikavi 40x100 cm EUR	1
81330	Veza korpe sa policom 8x100cm	1
81331	Veza korpe sa policom 6x100cm	1
81332	Sarka 100cm	1
81333	Polica staklo 985/300 sanduka	1
81334	Polica staklo 985/400 sanduka	1
81335	Polica drvena 47/98,5	1
81336	Polica žičana 1000/500	1
81337	Polica dubok 1000x500	1
81338	Polica 200/1000	1
81339	Polica 300/1000	1
81340	Polica 400/1000	1
81341	Polica 500/1000	1
81342	Polica 400/1000 RAL7015	1
81343	Polica 500/1000 RAL7015	1
81347	Kostur visoke saduke 1000/400	1
81348	Staklo kostura visoke saduke 1000/400	1
81349	Crčć	1
81350	Strop metalne police 500/100	1
81352	Čelna podrška visoka 1000 mm, staklo	1
81353	Čelna podrška visoka, pleKomi-staklo	1
81354	Čelna podrška niska 1000 mm, plastika	1
81355	Traka za cene, 1000mm	1
81356	Greben za crčć regala	1
81351	Greben za visoka pregrada, 1000	1
81357	Greben, 1000mm	1
81403	Greben za visoka pregrada, 1250 mm	1
81420	Greben za visoka pregrada, 625 mm	1
81358	Dupla žlijeb vrata saduka	1
81359	Držač trake za cene, 1000mm	1
81360	Vratašca vis. saduka 1000/2000	1
81361	Čelo poklopca, 1000mm	1
81362	Odbor poklopca, 1000mm	1
81363	Vratašca za ladica	1
81364	Vratašca za saduka	1
81365	Ogledalo za saduka	1
81366	Kostura vješanje modul 1	1
81367	Vješanje motka	1
81370	Koša žičana korpa	1
81371	Pult sa punom pločom 1000mm	1
81372	Podnožje pulta SU 5 1000mm	1
81373	Pult stakleni 1000mm	1
81374	Pult sa pločom od nerđajućeg č. 1000mm	1
81375	Pult sa punom pločom 600mm	1
81376	Polica za pult 600mm	1
81377	Pult stakleni 600mm	1
81378	Police za pult 1000mm	1
81379	Dugačka polica za pult	1
81380	Visoki segment pulta 90°	1
81381	Dvostruki žleb pulta 1000mm, par	1
81382	Pomična vratašca, pult 1000mm, par	1
81383	Ladica ispod ploče	1
81384	Žičana polica RDE 1000/360mm	1
81385	Žičana polica RDE 1000/460mm	1
81386	Žičana polica RDE 1000/560mm	1
81387	Traka za cene RDE 1000 mm	1
81388	Zadnji panel 100/1250mm puni	1

Br.	Specifikacija	
81389	Zadnji panel 200/1250mm puni	1
81390	Zadnji panel 400/1250mm puni	1
81391	Zadnji panel 200/1250mm šupljikavi	1
81393	Pokrivač korpe 80/1250mm	1
81392	Zadnji panel 400/1250mm šupljikavi	1
81394	Pokrivač korpe 60/1250mm	1
81395	Šarka 1250mm	1
81396	Polica 200/1250mm	1
81439	Šarka 1000 mm	1
81344	Polica 300/1000 pojačana	1
81345	Polica 400/1000 pojačana	1
81346	Polica 500/1000 pojačana	1
81397	Polica 300/1250mm	1
81400	Polica 300/1250mm, pojačana	1
81401	Polica 400/1250mm, pojačana	1
81402	Polica 500/1250mm, pojačana	1
81398	Polica 400/1250mm	1
81399	Polica 500/1250mm	1
81404	Niski čeon naslon 1250mm, bela plastika	1
81405	Traka za cene, 1250mm	1
81406	Greben 1250mm	1
81407	Držač trake za cene, 1250mm	1
81408	Celo poklopca, 1250mm	1
81409	Ploča poklopca, 600x1250mm	1
81410	Zadnji panel 100/625 puni	1
81411	Zadnji panel 200/625 puni	1
81412	Zadnji panel 400/625 puni	1
81413	Zadnji panel 400/625 šupljikavi	1
81414	Veza korpe sa policom 80/650	1
81415	Veza korpe sa policom 60/650	1
81416	Šarka, modul 3	1
81432	Sarka, 1330mm	1
81417	Polica 300/625	1
81418	Polica 400/625	1
81419	Polica 500/625	1
81421	Niski čeon naslon 625, bela plastika	1
81422	Traka za cene 625mm	1
81423	Greben 625mm	1
81424	Držač trake za cene, 625mm	1
81425	Zadnji panel 100/1330 puni	1
81457	Niski čeon naslon 200 plastika	1
81426	Zadnji panel 200/1330 puni	1
81427	Zadnji panel 400/1330 puni	1
81428	Zadnji panel 200/1330 šupljikavi S	1
81429	Zadnji panel 400/1330 šupljikavi S	1
81430	Pokrivač korpe 80/1330	1
81431	Pokrivač korpe 60/1330	1
81433	Polica 300/1330	1
81434	Polica 400/1330	1
81435	Polica 500/1330	1
81436	Traka za cene, 1330 mm	1
81437	Greben 1330 mm	1
81438	Držač trake za cene 1330 mm	1
81440	Polica žičana- korpa	1
81441	Zadnji panel 100 ugaoni	1
81442	Zadnji panel 400 ugaoni	1
81443	Čelo podnožja ugaono 500/1000 mm	1
81444	Čelo podnožja ugaono 600 mm	1
81445	Zadnji panel ugaono 400mm šupljikavi	1
81447	Polica 300 ugaono	1
81448	Polica 400 ugaono	1
81449	Polica 500 ugaono	1
81450	Polica 600 ugaono	1
81451	Držač trake za cene 300 ugaoni	1
81452	Držač trake za cene 400 ugaoni	1
81453	Držač trake za cene 500 ugaoni	1
81454	Traka za cene 300 ugaona	1
81455	Traka za cene 400 ugaona	1
81456	Traka za cene 500 ugaona	1
81458	Žičana polica- korpa U 1000/400	1
81459	Žičana polica- korpa U 1000/500	1
81460	Ugaono čelo podnožja 90°	1
81461	Zadnji panel ugaoni 100, stožac 60	1
81462	Zadnji panel ugaoni 200, stožac 60	1
81463	Zadnji panel ugaoni 400, stožac 80	1
81466	Zadnji panel ugaoni 100, stožac 80	1
81467	Zadnji panel ugaoni 400, stožac 60	1
81468	Polica ugaoni 90° 400mm	1
81469	Polica ugaoni 90° 500mm	1
81470	Ugaoni držač trake za cene 90° 400mm	1
81471	Ugaoni držač trake za cene 90° 500mm	1
81472	Traka za cene 90° 400mm ugaona	1
81473	Traka za cene 90° 500mm ugaona	1

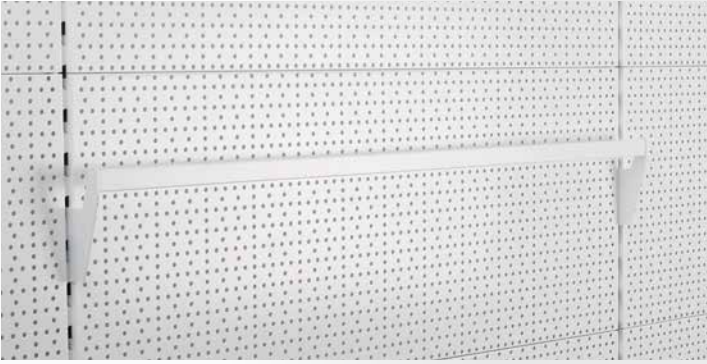

PRODAJNA KONZOLA

· Kompatibilno sa standom FESTA

Br.	Specifikacija	
81150	1000 × 50 × 135 mm	1

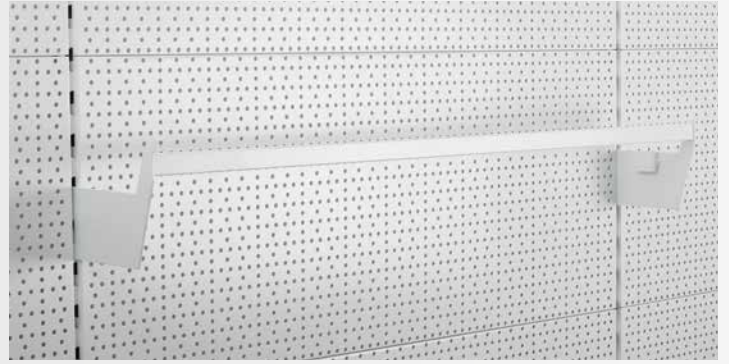

PRODAJNA KONZOLA

· Kompatibilno sa standom FESTA

Br.	Specifikacija	
81151	1000 × 150 × 135 mm	1

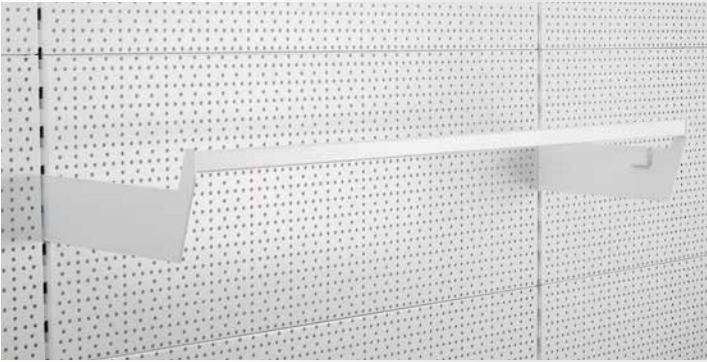

PRODAJNA KONZOLA

· Kompatibilno sa standom FESTA

Br.	Specifikacija	
81152	1000 × 350 × 135 mm	1

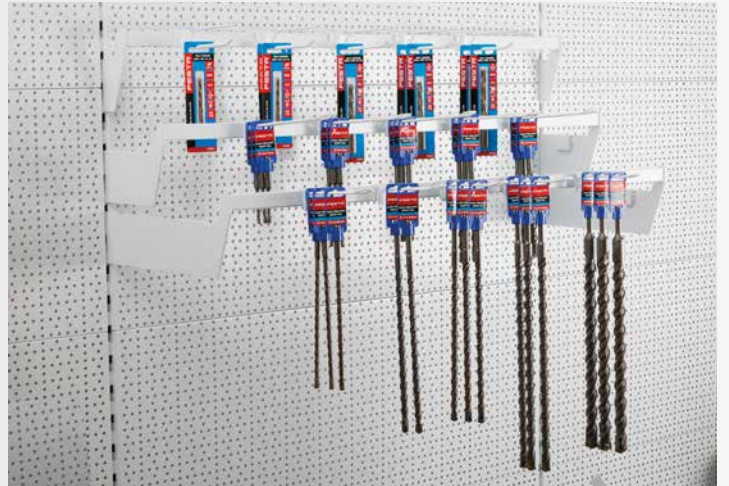

DRZAČ ZA CENE

· Kompatibilno sa standom FESTA

Br.	Specifikacija	
81155	1000 × 80 × 100 mm	1

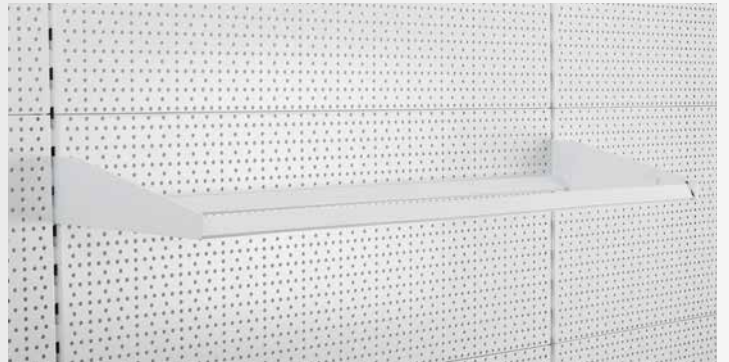

KONZOLA ZA REZNE PLOČE

· Kompatibilno sa standom FESTA

Br.	Specifikacija	
81170	1000 × 450 × 85 mm	1

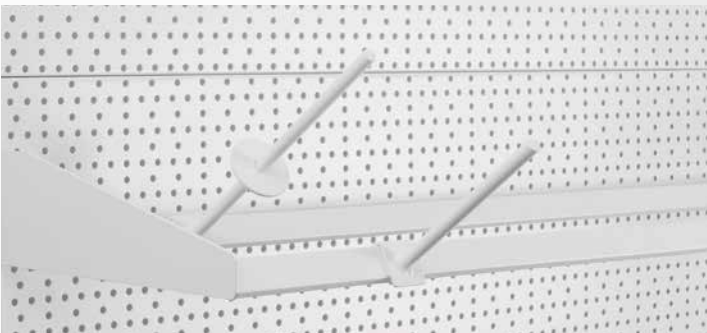

KUKE ZA REZNE PLOČE

· Kompatibilno sa standom FESTA

Br.	Specifikacija	
81186	150 mm	1
81185	250 mm	1



KUKA ZA AKUMULATORSKI ALAT

· Kompatibilno sa standom FESTA

Br.	Specifikacija	
81189		1

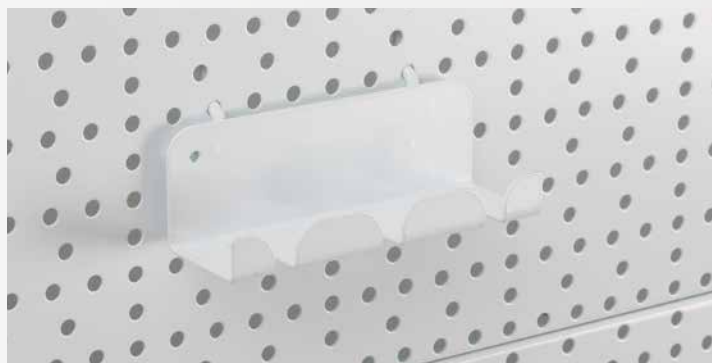

DRŽAČ ZA TESTERE

· Kompatibilno sa standom FESTA

Br.	Specifikacija	
81190		1



POLICE ZA REZNE PLOČE

· Kompatibilno sa standom FESTA

Br.	Specifikacija	
81191	220 x 220 x 200 mm	1

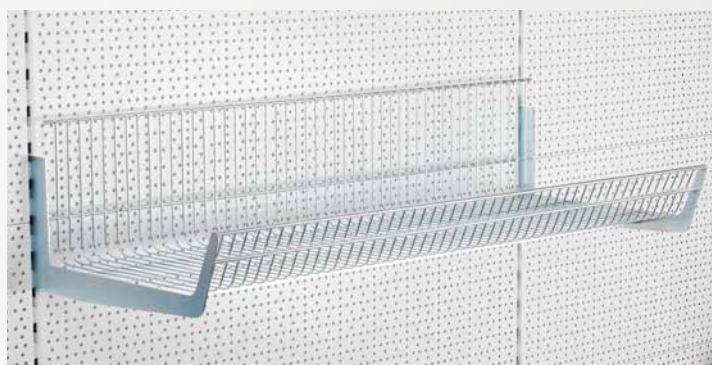

KOŠA ŽIČANA

· Kompatibilno sa standom FESTA

Br.	Specifikacija	
81160	1000 x 470 x 180 mm	1



PREGRAĐA

· Kompatibilno sa standom FESTA

Br.	Specifikacija	
81165	470 x 180 mm	1

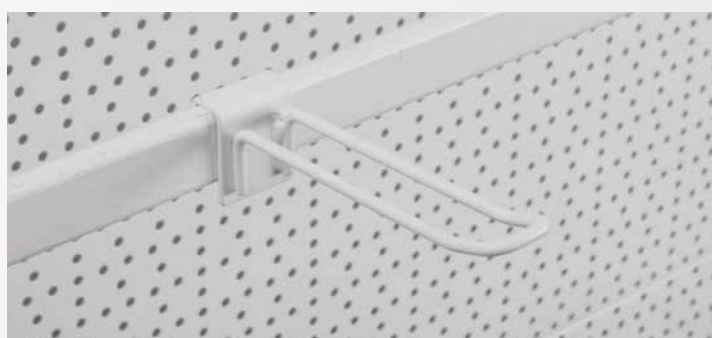

KUKA ZA HORIZONTALNU LAJSNU

· Kompatibilno sa standom FESTA

Br.	Specifikacija	
81175	120 mm	1
81178	180 mm	1



KUKA ZA HORIZONTALNU LAJSNU

· Kompatibilno sa standom FESTA

Br.	Specifikacija	
81180	120 mm	1



Kubala

GLETARICA ROST FREI

INOX

Br.	Specifikacija		
33100	130 x 270 mm	Glatka, 2 zaobljeni uglovi	10



Kubala

GLETARICA ROST FREI

INOX

Br.	Specifikacija		
33102	130 x 270 mm	Glatka, G-1 drška	10



Kubala

GLETARICA ROST FREI

INOX

Br.	Specifikacija		
33105	130 x 350 mm	Glatka, G-8 drška	6



Kubala

GLETARICA ROST FREI

INOX

Br.	Specifikacija		
33107	110 x 270 mm	Ugaona	10



Kubala

GLETARICA ROST FREI

INOX

Br.	Specifikacija		
33110	130 x 270 mm	Glatka, G-11 drška	10



Kubala

GLETARICA ROST FREI NAZUBJENA

INOX

Br.	Specifikacija		
33112	130 x 270 mm	Zubi 6 x 6, G-11 drška	10
33113	130 x 270 mm	Zubi 8 x 8, G-11 drška	10
33114	130 x 270 mm	Zubi 10 x 10, G-11 drška	10



Kubala

GLETARICA ROST FREI

INOX

Br.	Specifikacija		
33120	130 x 480 mm	Glatka, G-12 drška	10

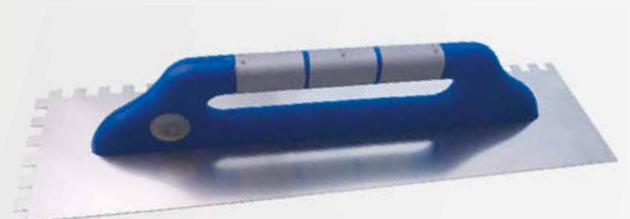

Kubala

GLETARICA ROST FREI NAZUBJENA

INOX

Br.	Specifikacija		
33123	130 x 480 mm	Zubi 8 x 8, G-12 drška	10
33124	130 x 480 mm	Zubi 10 x 10, G-12 drška	10



Kubala

GLETARICA ROST FREI

INOX

Br.	Specifikacija	
33127	130 x 480 mm	2 zaobljeni uglovi



Kubala

GLETARICA ROST FREI

INOX

Br.	Specifikacija	
33131	80 x 200 mm	G-1 drška
33132	75 x 95 x 240 mm	Tapez G-1 drška



Kubala

GLETARICA NAZUBIJENA

INOX

Br.	Specifikacija	
33135	130 x 270 mm	Kosi zubi 8 mm, G-1 drška



Kubala

GLETARICA NAZUBIJENA

INOX

Br.	Specifikacija	
33137	130 x 270 mm	Zubi, G-1 drška



Kubala

GLETARICA ROST FREI

INOX

Br.	Specifikacija	
33140	50 mm	20
33141	60 mm	20
33142	80 mm	20
33143	100 mm	20



Kubala

GLETARICA PLASTIČNA ABS

Br.	Specifikacija	
33150	130 x 240 mm	12

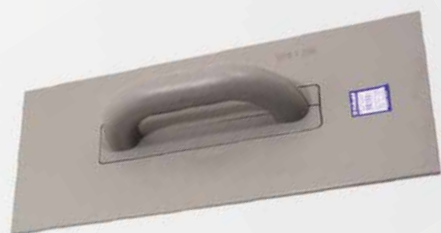

Kubala

GLETARICA PLASTIČNA

Br.	Specifikacija	
33151	180 x 400 mm	1
33152	130 x 600 mm	1



Kubala

GLETARICA PLASTIČNA

Br.	Specifikacija	
33154	130 x 270 mm	G-17 drška

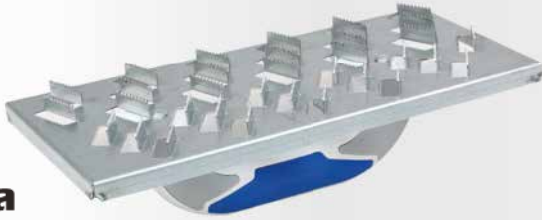

Kubala

GLETARICA SA CELICNIM TRAKAMA

Zn

MOQ
2

Br.	Specifikacija	MOQ
32328	285 x 145 mm	10



Kubala

DRŽAČ BRUSNE MREŽICE

Br.	Specifikacija	MOQ
33160	105 x 210 mm Gumeni	20

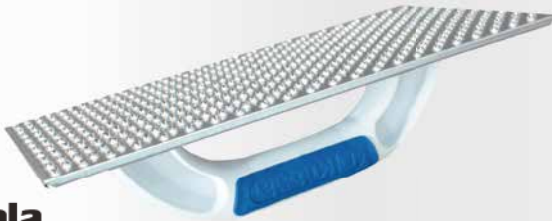

Kubala

BRUSNA GLETARICA

INOX

MOQ
2

Br.	Specifikacija	MOQ
33162	130 x 270 mm	20
33163	180 x 400 mm	10
33164	160 x 380 mm	10

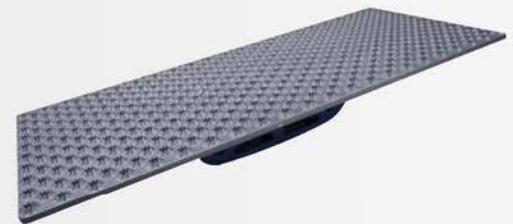

Kubala

PLASTIČNA BRUSNA GLETARICA

MOQ
2

Br.	Specifikacija	MOQ
33165	165 x 365 mm	10



Kubala

BRUSNA GLETARICA

MOQ
2

Br.	Specifikacija	MOQ
33169	160 x 380 mm Rupe, G-16 drška	10



Kubala

BRUSNA GLETARICA

MOQ
2

Br.	Specifikacija	MOQ
33167	130 x 270 mm G-17 drška	20
33168	160 x 380 mm G-17 drška	10
33170	180 x 400 mm G-17 drška	10



Kubala

ŠPAKLA ROST FREI

INOX

Br.	Specifikacija	
33200	40 mm	20
33201	60 mm	20
33202	80 mm	20
33203	100 mm	20



Kubala

ŠPAKLA ROST FREI

INOX

Br.	Specifikacija	
33205	130 x 90 mm	20



Kubala

ŠPAKLA ROST FREI

INOX

Br.	Specifikacija	
33206	130 x 37 mm	20



Kubala

ŠPAKLA ROST FREI

INOX

Br.	Specifikacija	
33207	150 mm Odvijač philips	30



Kubala

ŠPAKLA ROST FREI

INOX

Br.	Specifikacija	
33208	350 x 90 mm	10



Kubala

ŠPAKLA ROST FREI

INOX

Br.	Specifikacija	
33209	335 x 37 mm	20



Kubala

ŠPAKLA ROST FREI

INOX

Br.	Specifikacija	
33210	150 mm G-15 drška	10
33211	250 mm G-15 drška	10
33212	350 mm G-15 drška	10



Kubala

ŠPAKLA ROST FREI

INOX

Br.	Specifikacija	
33215	600 mm AL, G-14 drška	10



Kubala
ŠPAKLA PLASTIČNA

Br.	Specifikacija		
33220	145 mm	Guma	10



Kubala
ŠPAKLA PLASTIČNA

Br.	Specifikacija		
33221	245 mm	Guma	10



Kubala
GLETARICA PLASTIČNA

Br.	Specifikacija		
33155	95 x 240 mm	Gumeni	5



Kubala
SET FASADNI

Br.	Specifikacija		
33250			1



Kubala
KANTA

Br.	Specifikacija		
33254	16 l	Mrežica, točkiće	1
33255	20 l	Mrežica, točkiće	1



Kubala
SET FASADNI

Br.	Specifikacija		
33252			1



Kubala
REZERVNI VALJCI ZA PRANJE

Br.	Specifikacija		
33257	Valjaci za kanta		1



Kubala
REZERVNI VALJCI ZA PRANJE

Br.	Specifikacija		
33256	Valjaci za kanta		1
33258	Valjaci za kanta		1



Kubala

SPONE – DISTANCERI SMART LEVEL

Kajlice 33247, 33248, 33249

100x

Br.	Specifikacija	
33247	1 mm	15
33248	2 mm	15
33249	3 mm	15

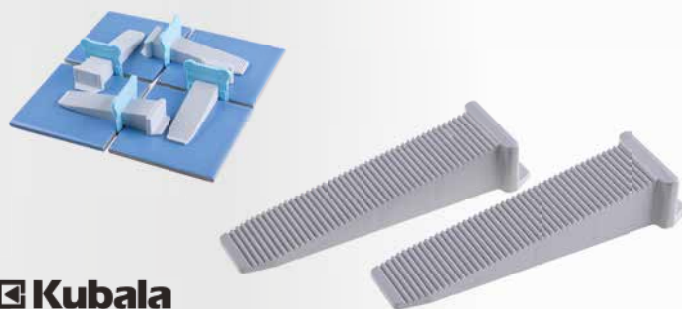

Kubala

KAJLE ZA NIVELACIJU

50x

Br.	Specifikacija	
33246	Smart Level	15



Kubala

FANGLA PLASTIČNA

Br.	Specifikacija	
33270	175 mm	20



Kubala

POSUDA ZA GIPS

Br.	Specifikacija	
33275	0,5 l	20



Kubala

GLADILICA SA GUMOM

Br.	Specifikacija	
33280	200 mm	10
37010	135 mm	20



Kubala

VALJAK

Br.	Specifikacija	
33289	85 x 230 mm	15



Kubala

STRUGALICA ZA FARBA

Br.	Specifikacija	
33285	60 mm	1
33286	Rezervno sečivo 60 mm	1



Kubala

BURGIJA ZA POROBETON

Br.	Specifikacija	
33291	60 mm	1
33292	80 mm	1
33293	120 mm	1



Kubala

PLASTIČNA UGAONA

Br.	Specifikacija	
33298	250 x 80 x 50 mm	1
33299	300 x 115 x 65 mm	1





AUTOMOTIVE 432 - 443





HIDRAULIČNA JEDNORUČNA DIZALICA

Šipka na izvlačenje omogućava malu početnu prilagodljivu visinu i maksimalno podizanje. Dvostruki sigurnosni propusni ventil. Nazubljene prihvate dizalice omogućava čvrst prihvata uz površinu. Široko postolje osigurava stabilnost i snagu. Sve kritične tačke su pojačane radi produženja roka trajanja dizalice i povećanja sigurnosti



Br.	Specifikacija	Nosivost	Minimalna visina	Visina podizanja	Prilagodljiva visina	Dimenzije postolja	Težina	
26800		2 000 kg	181mm	116 mm	48 mm	88 x 92 mm	2,6 kg	1
26801		3 000 kg	194 mm	118 mm	60 mm	92 x 100 mm	3,3 kg	1
26802		5 000 kg	216 mm	127 mm	70 mm	96 x 112 mm	4,5 kg	1
26803		8 000 kg	230 mm	147 mm	80 mm	103 x 118 mm	5,7 kg	1
26804		10 000 kg	230 mm	150 mm	80 mm	110 x 123 mm	6,8 kg	1
26805		12 000 kg	230 mm	155 mm	80 mm	116 x 134 mm	7,3 kg	1
26806		15 000 kg	230 mm	150 mm	80 mm	133 x 136 mm	8,4 kg	1
26807		20 000 kg	242 mm	150 mm	60 mm	144 x 152 mm	11 kg	1

HIDRAULIČNA JEDNORUČNA DIZALICA - TELESKOPSKA

Šipka na izvlačenje omogućava malu početnu prilagodljivu visinu i maksimalno podizanje. Dvostruki sigurnosni propusni ventil. Nazubljene prihvate dizalice omogućava čvrst prihvata uz površinu. Široko postolje osigurava stabilnost i snagu. Sve kritične tačke su pojačane radi produženja roka trajanja dizalice i povećanja sigurnosti.



Br.	Specifikacija	Nosivost	Minimalna visina	Visina podizanja	Prilagodljiva visina	Težina	
26815		2 000 kg	150 mm	160 mm	60 mm	4,7 kg	1
26816		4 000 kg	160 mm	170 mm	60 mm	6,4 kg	1
26817		6 000 kg	215 mm	270 mm	-	8,9 kg	1
26819		10 000 kg	228 mm	284 mm	89 mm	10,2 kg	1



RUČNA DIZALICA



Br.	Specifikacija	Nosivost	Minimalna visina	Maksimalna visina	Težina	
26844		1 000 kg	88 mm	380 mm	2,5 kg	1
26845		2 000 kg	120 mm	395 mm	3,5 kg	1



HIDRAULIČNA PRIJENOSNA DIZALICA – KOLICA



Br.	Specifikacija	Nosivost	Minimalna visina	Maksimalna visina	Težina	
26820		2 000 kg	130 mm	345 mm	9,6 kg	1
26826		2 000 kg	89 mm	359 mm	14,2 kg	1
26824		3 000 kg	145 mm	500 mm	37,2 kg	1
26825		2 500 kg	85 mm	455 mm	34,8 kg	1



HIDRAULIČNA PRIJENOSNA DIZALICA – KOLICA + 2 POTPORNJA

Okretna ručka za 360°



Br.	Specifikacija	Nosivost	Minimalna visina	Maksimalna visina	Težina	
26829	Hidraulična dizalica - kolica	2 000 kg	130 mm	350 mm	10,5 kg	1
	2 komada podupirača	2 000 kg	275 mm	420 mm	5 kg (pair)	



PODESIVA POTPORNJA DIZALICA

1 kom. = 1 par. Zupčasti prijenos za finu prilagodbu sa dvostrukom kočnicom. Čvrsta čelična ručka. Velik dosjed, sklopna konstrukcija okvira. Postolje od kovanog željeza.

Br.	Specifikacija	Nosivost	Minimalna visina	Maksimalna visina	Težina	
26857	Sa zaporom	2 000 kg	275 mm	420 mm	4,8 kg	1
26858	Sa zaporom	3 000 kg	285 mm	425 mm	6,3 kg	1
26859	Sa zaporom	6 000 kg	393 mm	593 mm	13 kg	1
26853		12 000 kg	465 mm	715 mm	28 kg	1



HIDRAULIČNA KRAN DIZALICA

Za podizanje i fiksiranje dijelova kod montaže i demontaže u automobilima. Nosač kрана ima nekoliko pozicija za izvlačenje. Kran se lako sklapa za skladištenje.

Br.	Specifikacija	Nosivost	Minimalna visina	Maksimalna visina	Težina	
26862		2 000 kg	0	2360 mm	88 kg	1



PRENOSNA ŠIPKA ZA DIZANJE

Produljenje za ruku dizalice, ovisno o nagibu.
Jamstvo za sigurno i balansirano fiksiranje motora.



Br.	Specifikacija	Nosivost	Dužina	Prilagodljivost ruci kрана	Težina	
26871		500 kg	1500 mm	150 mm	20,3 kg	1



26880

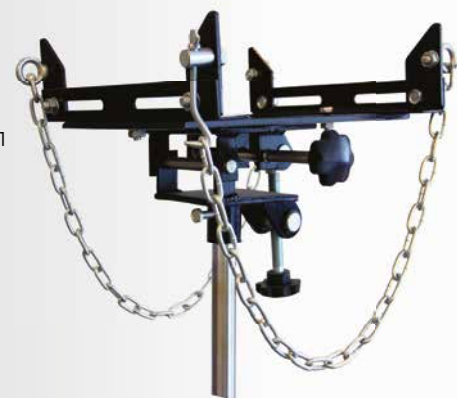

26881

PRIJENOSNA DIZALICA

Lagana montaža i demontaža dijelova (motori, prijenosnici, osovine i sl.).



Br.	Specifikacija	Nosivost	Dužina	Prilagodljivost ruci kрана	Težina	
26880	Prijenosna dizalica	500 kg	1100 mm	1900 mm	30,0 kg	1
26881	Nastavak za dizalicu sa mogućnošću proširenja	500 kg	1100 mm	1900 mm	15,0 kg	1



NC KOMPLET

Hidraulična oprema za popravak karoserije vozila.
Opremljena stepnim cilindrom sa 14 dodatnih priključaka.
Široka primjena u popravcima karoserije automobila i kamiona, naročito u uvjetima rada bez mogućnosti napajanja ostalim izvorima energije.
Tijekom upotrebe cilindra, priključci (nastavci) mogu gurati, vući podizati ili izvlačiti u vertikalnom i horizontalnom pravcu. Lako prenosiva oprema u svom koferu.



Br.	Specifikacija	Nosivost	Visina podizanja	Težina	
26886		4 000 kg	125 mm	17,0 kg	1
26888		10 000 kg	135 mm	32,0 kg	1



26920



26921



26922

STALAK ZA MOTOR

Pokretni stalak za montiranje i rad na demontiranim motorima. Univerzalna stega za pričvršćivanje motora i njegovo okretanje.



Br.	Specifikacija	Nosivost	Težina	
26920		450 kg	20 kg	1
26921		560 kg	27 kg	1
26922	Sklopivi	675 kg	35 kg	1

RUČNO VITLO

Zn

Visokokvalitetno pocinčano vitlo sa izrazito otpornom i jakim sajlom.



Br.	Specifikacija	Ø Promjer sajle	Naziv Maksimalno zatezanje	Duljina sajle	
26705		4,0mm	450 kg	10 m	1
26706		5,0mm	900 kg	10 m	1
26707		6,0mm	1350 kg	10 m	1
26720		4,0mm	300 kg	10 m	1
26721		4,0mm	500 kg	10 m	1
26722		5,0mm	800 kg	10 m	1

LANČANA DIZALICA – KOTUR



Br.	Specifikacija	Nosivost	Minimalna visina	Visina podizanja	Broj koluta	Ilanac	Težina	
26700		500 kg	280 mm	3 000 mm	1	6 mm	7,5 kg	1
26701		1 000 kg	300 mm	3 000 mm	1	6 mm	9 kg	1
26702		2 000 kg	380 mm	3 000 mm	2	6 mm	12 kg	1



26897

26943

KOMPRESOR ZA OPRUGE

26897 - Za zamjenu Mc Pherson opruga/amortizera na samom vozilu

26943 - Za vađenje Mc Pherson opruga/amortizera iz vozila, hrpavi čelični profili za veću stabilnost



Br.	Specifikacija	Nosivost	Ø Promjer komprimirane opruge	Prilagodljivost	Težina	
26897	Kompresor za opruge	1 000 kg	100-200 mm	150 mm	24,5 kg	1
26943	Kompresor za opruge	1 000 kg	400 mm	210-570 mm	35 kg	1



HIDRAULIČNA PREŠA

Br.	Specifikacija	Prilagodljivost	Nosivost	Težina	
26940		0 - 610 mm	12 000 kg	43 kg	1
26941		0 - 880 mm	20 000 kg	75 kg	1

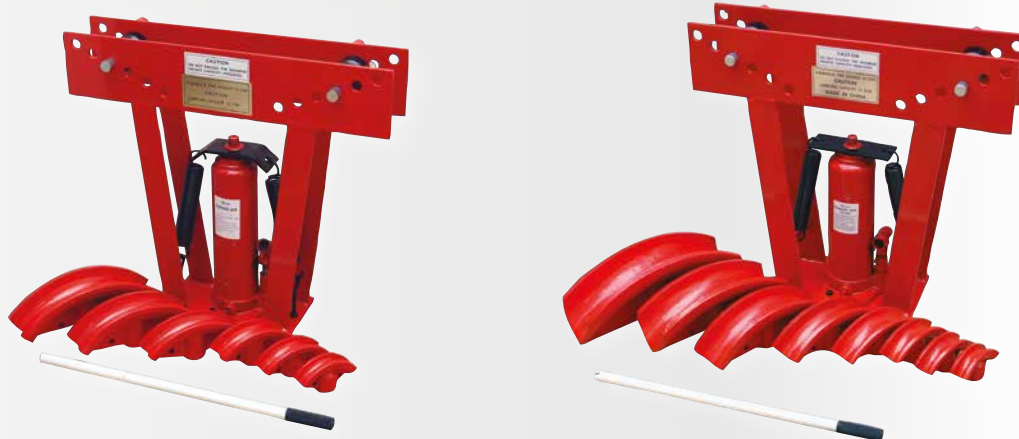

HIDRAULIČNI SAVIJAČ CIJEVI

Br.	Specifikacija	Nosivost	Visina podizanja	Kalup za savijanje	Težina	
26895		12 000 kg	232 mm	1 2", 3 4", 1", 1-1 4", 1-1 2", 2"	36 kg	1
26896		16 000 kg	238 mm	1 2", 3 4", 1", 1-1 4", 1-1 2", 2", 2-1 2", 3"	65 kg	1



HIDRAULIČNI DUGAČKI KLIP



Br.	Specifikacija	Nosivost	Min. Dužina (mm)	Maks. visina (mm)	Težina	
26911	Hidraulični dugački klip, jednostruka pumpa	5 000 kg	620	1100	12 kg	2
26912	Hidraulični dugački klip, jednostruka pumpa	8 000 kg	620	1100	13 kg	2
26914	Hidraulični dugački klip, dvostruka pumpa	5 000 kg	620	1100	12 kg	2
26915	Hidraulični dugački klip, dvostruka pumpa	8 000 kg	620	1100	14 kg	2



POSUDA ZA PRANJE DELOVA

Za uobičajeno pranje predmeta (delova, mašinskih delova, itd.)



Br.	Specifikacija	Kapacitet spremnika	Volumen spremnika za otapala	Protok	Maksimalna temperatura otapala	Težina	
26961		90 l	45 l	10-12 l/min.	50°C	25 kg	1
26963		180l	150 l	20 l/min	50°C	42 kg	1

REZERVOAR ZA ULJE – ISTAKAČ ULJA

Ulje je izvučeno iz motora u spremnik kroz posudu.
Spremnik je opremljen opremom za ispušavanje.
Ulje može biti ispušano iz spremnika pod tlakom zraka kroz crijevo.



Br.	Kapacitet spremnika	Maks. tlak	Težina	
26954	90 l	0,5 MPa	28 kg	1



IZVLAKAČ LEŽAJEVA – RADAPCIGER



Br.	Max. promjer	Dubina	
23734	Ø 100 mm	50-95 mm	1
23735	Ø 150 mm	100-150 mm	1
23736	Ø 200 mm	110-190 mm	1



IZVLAKAČ LEŽAJEVA – RADAPCIGER



Br.	Max. promjer	Dubina	
23730	Ø 100 mm	50-95 mm	12
23731	Ø 150 mm	100-150 mm	2
23732	Ø 200 mm	110-190 mm	2

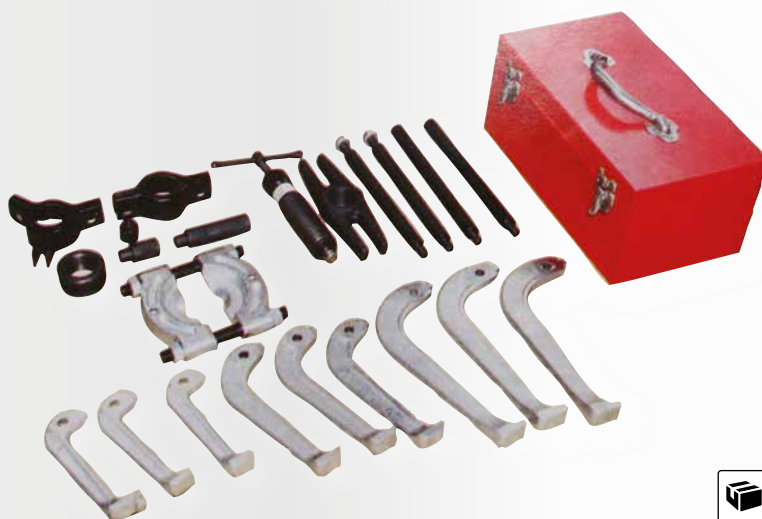

HIDRAULIČNI IZVLAKAČ

Hidraulični set za izvlačenje uključujući vijak za izvlačenje sa pripadajućim vilicama i 3 kompleta po 3 kraka i španera. U čeličnom koferu.

Br.	Specifikacija	Nosivost	Težina	
26891		12 000 kg	18 kg	1



REZERVNI DELOVI ZA KABINET ZA PESKARANJE

Č.p.		
26973	rukavice	1
26974	mlaznice	1
26975	folija 53,5 x 26 cm	1
26976	pleksiglas 60 x 30 cm	1
26977	staklo 60 x 30 cm	1

KABINA ZA PESKARENJE 220L

Br.	Potrošnja zraka	Vanjske dimenzije	Unutarnje dimenzije	Maks. tlak	Težina	
26972	420-710 l/min.	1500 x 830 x 630 mm	600 x 840 x 630 mm	8 bar	38 kg	1

**FESTA****POKRETNI ORMAR ZA ALAT**

Br.	Putovanja ladice	Crtač	Vanjske dimenzije	
26986	Klizna	7	680 x 460 x 1020 mm	1

**POKRETNI ORMAR ZA ALAT**

Gornji dio se može umetnuti u donji dio kabine.

Br.	Specifikacija	Putovanja ladice	Crtač	ladice dimenzije	Vanjske dimenzije	Težina	
26985	Gornji dio	Klizna	3	151,5 x 225 x 40 mm	600 x 260 x 340 mm	11,5 kg	1
			2	511 x 225 x 40 mm			
	Donji dio	Klizna	1	511 x 225 x 85 mm	616 x 330 x 742 mm	16,4 kg kg	
			2	511 x 308 x 85 mm			



MAGNETNI TANJIR



Br.	Specifikacija	
26996	200 x 20 mm	1



ZATEZAČ ZA OGRADE



Br.	Specifikacija	
50035	2 t	6
50036	4 t	4



ZASTITNA KOLICA ZA KOLENA



Br.	
37135	1



AUTOMEHANIČARSKA LEŽALJKA

Podstavljeno sjedište sa plastičnom posudom za alat.

Br.	Specifikacija	
26988	360 x 365 x 365 mm	1



MINI HIDRAULIČNA DIZALICA ZA MOTOR

Br.	
26998	1

broj artikla	strana	broj artikla	strana	broj artikla	strana	broj artikla	strana	broj artikla	strana	broj artikla	strana
10002	26	12020	31	13275	51	13452	32	14077	35	15230	40
10003	26	12030	31	13276	52	13453	32	14080	34	15235	40
10005	26	12050	31	13277	55	13454	32	14090	35	15310	40
10008	26	12110	31	13278	51	13455	32	14091	35	15315	40
10025	26	12120	31	13279	50	13456	32	14220	36	15318	40
10033	26	12130	31	13280	51	13457	32	14225	36	15320	40
10035	26	12150	31	13281	55	13458	32	14230	36	15325	40
10043	26	12210	31	13282	55	13459	32	14235	36	15330	40
10045	26	12220	31	13284	50	13460	32	14240	36	15335	40
10048	26	12230	31	13285	55	13461	32	14250	36	15340	40
10110	27	12250	31	13290	92	13462	32	14350	36	15415	41
10120	27	12433	31	13293	92	13463	32	14360	36	15418	41
10130	27	12435	31	13294	92	13464	32	14370	36	15420	41
10330	27	13010	32	13295	57	13465	32	14380	36	15425	41
10332	27	13020	32	13296	57	13466	32	14399	36	15430	41
10334	27	13021	32	13350	56	13467	32	14410	37	15510	41
10336	27	13022	32	13351	56	13468	32	14411	37	15515	41
10430	27	13023	32	13352	56	13469	32	14415	36	15518	41
10450	27	13111	32	13353	56	13470	32	14417	36	15520	41
10490	27	13120	32	13354	56	13471	32	14420	36	15525	41
10996	27	13205	54	13355	56	13472	32	14421	36	15530	41
10998	27	13206	54	13360	56	13473	32	14425	37	15535	41
10999	27	13207	54	13361	56	13500	30	14430	37	15540	41
11002	29	13208	54	13362	56	13501	30	14435	37	15615	41
11003	29	13210	32	13363	56	13502	30	14440	37	15620	41
11005	29	13211	32	13364	56	13503	30	14450	37	15625	41
11006	29	13212	54	13365	56	13504	30	14451	37	15630	41
11007	29	13214	53	13399	33	13505	30	14455	37	15710	41
11008	29	13216	53	13400	33	13506	30	14456	37	15715	41
11082	29	13217	53	13401	32	13507	30	14457	37	15720	41
11083	29	13218	53	13402	32	13508	30	14458	37	15725	41
11085	29	13219	53	13403	32	13509	30	14471	37	15730	41
11102	29	13220	32	13404	32	13510	30	14472	37	15735	41
11103	29	13222	53	13405	32	13511	30	14473	37	15740	41
11105	29	13223	53	13406	32	13512	30	14474	37	15810	42
11106	29	13224	53	13407	32	13513	30	14480	35	15812	42
11107	29	13225	53	13408	32	13514	30	14485	37	15815	42
11110	29	13226	53	13409	32	13515	30	14485	42	15818	42
11200	29	13227	53	13410	32	13516	30	14486	37	15820	42
11201	29	13228	53	13411	32	13517	30	14486	42	15825	42
11202	29	13229	53	13412	32	13518	30	14490	37	15830	42
11204	29	13230	53	13413	32	13519	30	14491	37	15850	42
11205	29	13231	53	13414	32	13520	30	14492	37	15853	42
11206	29	13235	53	13415	32	13521	30	14493	37	15855	42
11207	29	13236	53	13416	32	13522	30	14494	37	15860	42
11208	29	13237	53	13417	32	13523	30	15003	39	15870	42
11209	29	13238	53	13418	32	13524	30	15004	39	15880	42
11210	29	13240	55	13419	32	13525	30	15005	39	15885	259
11220	28	13241	55	13420	32	13526	30	15006	39	15886	259
11221	28	13242	55	13421	32	13527	30	15008	39	15886	383
11226	28	13243	55	13422	32	13528	30	15010	39	15887	259
11239	28	13244	55	13423	32	13529	30	15012	39	15887	383
11259	28	13245	55	13424	32	13530	30	15015	39	15888	259
11260	28	13246	54	13425	32	13531	30	15018	39	15888	383
11311	30	13249	56	13426	32	13532	30	15020	39	15889	259
11312	30	13250	56	13427	32	13533	30	15033	38	15904	43
11313	30	13251	56	13428	32	13534	30	15034	38	15906	43
11314	30	13252	56	13429	32	14001	34	15035	38	15908	43
11323	28	13253	56	13430	32	14002	34	15036	38	15910	43
11325	28	13254	56	13431	32	14003	34	15037	38	15912	43
11327	28	13255	57	13432	32	14004	34	15039	38	15915	43
11333	29	13256	57	13433	32	14006	34	15103	39	15920	43
11335	29	13257	57	13434	32	14007	34	15104	39	15954	43
11337	29	13258	57	13435	32	14008	34	15105	39	15956	43
11338	29	13259	57	13436	32	14009	34	15106	39	15958	43
11343	28	13260	55	13437	32	14010	33	15108	39	15960	43
11345	28	13261	52	13438	32	14011	33	15110	39	15962	43
11347	28	13262	50	13439	32	14012	33	15112	39	15965	43
11353	28	13263	50	13440	32	14013	34	15115	39	15970	43
11355	28	13264	51	13441	32	14015	33	15118	39	15980	44
11356	28	13265	50	13442	32	14017	33	15120	39	15981	44
11358	28	13266	50	13443	32	14019	33	15204	40	15983	31
11360	28	13267	50	13444	32	14025	37	15205	40	15985	31
11410	30	13268	51	13445	32	14030	33	15206	40	15988	31
11416	29	13269	50	13446	32	14035	34	15208	40	15989	31
11420	30	13270	50	13447	32	14040	34	15210	40	15990	44
11425	30	13271	50	13448	32	14045	34	15212	40	15991	44
11444	30	13272	51	13449	32	14060	35	15215	40	15992	44
11445	30	13273	51	13450	32	14070	35	15218	40	15993	44
12010	31	13274	52	13451	32	14075	35	15220	40	15996	42

broj artikla	strana	broj artikla	strana	broj artikla	strana	broj artikla	strana	broj artikla	strana	broj artikla	strana
15997	42	16085	167	16991	177	17083	69	17211	73	17351	114
15998	42	16086	167	16991	344	17084	66	17212	74	17352	114
15999	42	16090	165	16998	163	17085	66	17213	74	17353	114
16002	162	16091	165	16999	163	17086	66	17214	74	17357	114
16003	162	16095	167	17001	62	17089	70	17215	74	17359	114
16004	163	16100	164	17002	62	17090	70	17216	75	17360	114
16005	163	16105	164	17003	62	17091	70	17217	75	17361	114
16006	163	16110	164	17004	62	17092	70	17218	75	17380	85
16010	163	16115	164	17005	62	17093	70	17219	75	17381	85
16010	163	16120	164	17006	62	17094	62	17220	77	17382	85
16011	162	16125	164	17007	62	17095	62	17222	77	17383	85
16011	162	16130	166	17008	62	17096	62	17224	77	17384	85
16011	163	16131	164	17009	62	17097	62	17225	76	17385	85
16012	162	16135	166	17010	62	17098	62	17226	76	17386	85
16012	162	16136	165	17011	62	17099	62	17227	76	17390	86
16012	163	16137	165	17012	66	17100	62	17229	78	17391	86
16013	163	16140	166	17013	66	17101	61	17230	79	17392	86
16013	163	16141	169	17014	66	17102	61	17231	79	17393	86
16016	163	16142	165	17015	69	17103	61	17233	79	17394	86
16017	163	16143	165	17016	69	17104	61	17234	79	17395	86
16019	162	16144	165	17017	69	17105	61	17235	80	17396	86
16021	169	16145	165	17019	69	17108	62	17236	80	17397	86
16022	173	16146	166	17020	68	17109	65	17237	80	17398	86
16023	167	16147	166	17021	68	17110	62	17238	110	17400	86
16024	169	16150	164	17022	68	17111	70	17238	78	17401	85
16025	166	16151	164	17023	65	17112	70	17240	81	17402	85
16026	169	16198	176	17024	62	17116	70	17241	81	17405	85
16028	169	16199	176	17025	64	17117	70	17242	81	17406	85
16029	166	16201	173	17026	179	17121	70	17243	81	17407	85
16030	168	16202	63	17027	179	17122	70	17244	81	17410	85
16031	168	16209	175	17028	68	17125	63	17245	78	17411	85
16032	168	16210	174	17029	68	17126	63	17247	111	17412	85
16033	168	16211	174	17033	66	17127	63	17250	77	17413	85
16034	166	16212	173	17034	65	17128	63	17255	77	17414	85
16035	168	16218	174	17035	65	17130	63	17259	111	17415	85
16036	168	16219	174	17036	65	17133	63	17260	110	17416	85
16037	167	16220	174	17037	179	17135	63	17261	91	17420	85
16038	168	16221	174	17038	69	17137	63	17262	91	17421	85
16041	168	16222	175	17039	68	17138	63	17292	81	17422	85
16042	170	16223	175	17040	64	17140	61	17294	81	17427	85
16042	284	16224	175	17041	64	17142	61	17295	81	17450	91
16043	169	16225	173	17042	64	17145	61	17296	81	17451	91
16046	169	16226	175	17043	64	17146	61	17297	81	17455	86
16049	170	16227	175	17044	64	17148	61	17298	81	17456	86
16050	170	16228	175	17045	64	17155	71	17299	81	17458	86
16051	170	16229	173	17046	68	17156	71	17300	69	17459	86
16052	170	16230	173	17047	64	17158	72	17301	69	17460	88
16053	169	16231	127	17048	68	17159	72	17302	69	17461	88
16054	170	16231	173	17050	72	17160	72	17303	69	17462	88
16055	169	16232	65	17050	179	17165	71	17304	69	17463	88
16056	284	16232	176	17051	68	17167	71	17305	69	17464	88
16057	167	16234	173	17052	68	17169	71	17306	69	17465	88
16058	167	16235	174	17053	68	17170	71	17308	82	17466	88
16059	170	16236	174	17054	68	17175	71	17309	82	17467	88
16060	172	16281	177	17055	68	17177	71	17310	82	17468	88
16061	172	16282	177	17056	68	17180	63	17311	82	17469	88
16062	171	16300	180	17057	68	17181	63	17312	82	17470	88
16063	171	16301	180	17058	68	17182	178	17313	82	17471	88
16064	171	16303	180	17059	66	17183	178	17314	82	17472	88
16065	171	16304	180	17060	66	17185	72	17315	82	17473	88
16066	164	16310	180	17061	66	17186	71	17316	82	17475	89
16066	171	16310	180	17062	66	17187	139	17317	82	17476	89
16067	171	16311	180	17063	67	17188	139	17318	82	17480	88
16068	171	16311	180	17064	67	17189	139	17319	82	17481	88
16069	170	16311	180	17065	67	17190	64	17320	82	17482	88
16070	170	16312	180	17066	67	17191	64	17321	82	17483	88
16070	172	16312	180	17067	67	17192	64	17322	82	17484	88
16071	167	16315	179	17068	67	17193	64	17324	82	17485	88
16071	172	16315	179	17069	67	17197	88	17327	82	17486	88
16072	172	16320	180	17070	67	17198	88	17330	82	17487	87
16073	172	16321	143	17071	67	17199	88	17332	82	17488	87
16074	167	16321	180	17072	67	17200	88	17333	82	17489	87
16074	172	16401	72	17075	67	17201	88	17334	82	17490	87
16075	172	16405	72	17076	67	17202	88	17335	77	17491	87
16077	171	16406	72	17077	67	17203	91	17336	77	17492	87
16078	171	16407	72	17078	69	17204	91	17337	77	17493	87
16081	171	16408	72	17079	66	17205	91	17338	77	17494	87
16082	170	16420	72	17080	66	17206	91	17345	76	17495	87
16083	172	16990	177	17081	66	17208	77	17346	76	17496	87
16084	172	16990	344	17082	66	17210	73	17350	114	17501	90

broj artikla	strana	broj artikla	strana	broj artikla	strana	broj artikla	strana	broj artikla	strana	broj artikla	strana
17506	89	17631	87	17851	83	18066	94	18416	99	18607	106
17508	89	17632	87	17852	83	18067	94	18417	99	18608	98
17512	89	17633	87	17853	83	18070	94	18418	97	18610	106
17526	89	17640	90	17854	83	18071	94	18419	99	18611	106
17528	89	17642	90	17855	83	18072	94	18420	99	18612	106
17532	89	17643	90	17856	83	18075	94	18421	109	18613	106
17533	89	17644	90	17860	82	18076	94	18422	95	18614	106
17534	89	17645	90	17861	82	18077	94	18423	96	18615	106
17539	89	17650	90	17862	82	18080	94	18424	95	18618	106
17548	87	17651	90	17863	82	18081	94	18425	98	18619	105
17549	87	17652	90	17864	82	18082	94	18426	96	18619	86
17550	87	17653	90	17865	82	18083	94	18430	109	18620	103
17551	87	17654	90	17866	82	18084	94	18431	99	18621	103
17552	87	17655	90	17867	82	18085	94	18433	98	18623	103
17553	87	17656	90	17868	82	18086	94	18435	100	18625	103
17554	87	17657	90	17869	82	18087	94	18437	96	18627	103
17555	87	17658	90	17870	82	18088	94	18440	109	18628	103
17556	87	17659	90	17871	82	18089	94	18450	98	18630	103
17557	87	17660	87	17872	82	18090	94	18451	98	18631	103
17558	87	17661	87	17873	82	18091	94	18455	94	18632	103
17559	87	17662	87	17874	82	18092	94	18456	94	18632A	102
17560	87	17663	87	17875	82	18101	97	18460	94	18633	103
17561	87	17664	87	17876	82	18102	97	18466	113	18633A	102
17562	87	17665	87	17877	82	18103	97	18468	113	18634	103
17563	87	17666	87	17878	82	18104	97	18476	113	18635	103
17564	87	17667	87	17879	82	18105	97	18477	113	18636	103
17565	87	17668	87	17880	82	18106	97	18490	112	18636A	102
17566	87	17669	87	17881	82	18107	97	18491	112	18637	103
17567	87	17670	87	17882	82	18108	97	18492	112	18637A	102
17568	87	17671	87	17883	82	18110	98	18493	112	18638	103
17569	87	17672	87	17884	82	18113	93	18494	114	18638A	102
17570	87	17674	87	17885	82	18114	93	18495	114	18639	103
17571	87	17675	87	17886	82	18115	93	18496	112	18640	103
17572	87	17676	87	17887	82	18116	93	18497	112	18641	103
17573	87	17677	87	17888	82	18118	93	18498	112	18645	103
17574	87	17678	87	17889	82	18120	93	18499	114	18646	103
17575	87	17679	87	17890	82	18124	93	18500	112	18680	103
17576	87	17680	90	17891	82	18125	93	18508	113	18685	103
17577	87	17681	90	17892	82	18201	97	18510	113	18750	103
17578	87	17682	90	17895	83	18202	97	18511	113	18751	103
17579	87	17683	87	17896	83	18203	97	18512	113	18753	103
17580	87	17685	88	17897	83	18204	97	18513	113	18755	103
17581	87	17761	88	17898	83	18210	93	18514	113	18760	103
17582	87	17769	88	17902	83	18211	93	18515	113	18761	103
17583	87	17788	88	17904	83	18212	93	18516	113	18762	103
17584	87	17789	88	17905	83	18215	93	18518	113	18763	103
17585	87	17795	88	17907	83	18216	93	18519	113	18764	103
17586	87	17806	88	17910	83	18301	97	18520	113	18765	103
17587	87	17810	82	17912	83	18302	97	18521	113	18766	103
17589	87	17811	82	17913	83	18303	97	18522	113	18767	103
17590	87	17812	82	17914	83	18304	97	18523	113	18768	103
17591	87	17820	82	17916	83	18310	93	18524	113	18769	103
17592	87	17821	82	17922	83	18311	93	18527	113	18770	103
17593	87	17822	82	17924	83	18312	93	18548	113	18771	103
17600	91	17823	82	17925	83	18313	93	18559	113	18772	103
17601	91	17824	82	17926	83	18321	93	18562	113	18775	103
17603	91	17825	82	17927	83	18322	93	18567	113	18776	103
17605	88	17826	82	17930	83	18340	95	18572	113	18777	103
17606	88	17827	82	17931	83	18350	94	18575	113	18795	105
17607	88	17828	82	17932	83	18351	94	18576	113	18796	105
17608	88	17829	82	17933	83	18352	94	18577	113	18797	105
17609	88	17830	82	17934	83	18353	94	18578	113	18798	105
17610	88	17831	82	17935	83	18354	94	18579	113	18799	106
17611	88	17832	82	17943	83	18355	94	18580	113	18800	104
17612	88	17835	83	17944	83	18356	94	18581	113	18801	104
17613	88	17836	83	17970	104	18357	94	18582	113	18802	104
17614	88	17837	83	17971	104	18358	94	18583	113	18803	104
17615	88	17838	83	17972	104	18359	94	18584	113	18804	104
17616	88	17839	83	17973	104	18360	94	18585	113	18805	104
17617	88	17840	83	17974	104	18400	97	18586	113	18806	104
17620	90	17841	83	17975	104	18401	97	18587	113	18807	104
17621	90	17842	83	17976	104	18402	95	18588	113	18810	104
17622	87	17843	83	17980	104	18403	95	18589	113	18811	104
17623	87	17844	83	17981	104	18404	95	18593	113	18812	104
17624	87	17845	83	17982	104	18408	100	18600	105	18813	104
17625	87	17846	83	17983	104	18409	100	18601	105	18814	104
17626	87	17847	83	18062	94	18410	96	18602	106	18815	104
17628	87	17848	83	18063	94	18411	96	18603	81	18816	104
17629	87	17849	83	18064	94	18413	96	18604	86	18817	104
17630	87	17850	83	18065	94	18415	99	18605	106	18820	104

broj artikla	strana	broj artikla	strana	broj artikla	strana	broj artikla	strana	broj artikla	strana	broj artikla	strana
18821	104	18957	84	19115	142	19410	126	19537	185	19607	185
18822	104	18960	84	19124	118	19410	202	19538	185	19608	185
18823	104	18961	84	19136	118	19411	126	19539	185	19609	185
18824	104	18963	84	19148	118	19411	202	19540	185	19610	185
18825	104	18971	84	19149	118	19412	126	19540	185	19610	185
18826	104	18993	107	19150	117	19412	202	19541	185	19611	185
18827	104	18994	107	19151	117	19415	125	19542	185	19612	185
18827A	102	19001	116	19200	120	19416	125	19543	185	19613	185
18828	104	19002	116	19202	120	19418	126	19544	185	19614	185
18828A	102	19003	116	19208	121	19418	202	19545	185	19615	185
18829	104	19004	116	19209	121	19419	126	19545	185	19615	185
18830	104	19005	116	19211	121	19419	202	19546	185	19616	185
18830A	102	19006	116	19245	120	19421	125	19547	185	19617	185
18831	104	19008	116	19246	120	19422	125	19548	185	19618	185
18831A	102	19010	116	19247	120	19423	125	19550	185	19619	185
18832	104	19015	116	19248	120	19424	125	19550	185	19620	185
18835	104	19020	116	19249	120	19425	125	19552	185	19620	185
18836	104	19021	116	19251	121	19426	125	19552	185	19621	185
18837	104	19022	116	19252	121	19427	125	19553	185	19622	185
18838	104	19023	116	19253	121	19429	202	19554	185	19623	185
18839	104	19024	116	19254	120	19430	119	19555	185	19624	185
18840	104	19025	116	19255	120	19431	119	19555	185	19625	185
18841	104	19026	116	19265	120	19432	119	19556	185	19625	185
18842	104	19028	116	19270	120	19433	119	19557	185	19626	185
18843	104	19030	116	19271	120	19434	119	19558	185	19627	185
18844	104	19031	116	19272	120	19435	119	19558	185	19628	185
18845	104	19032	116	19290	120	19436	126	19559	185	19629	185
18846	104	19034	116	19293	120	19436	202	19560	185	19630	185
18847	104	19036	116	19294	120	19440	119	19560	185	19630	185
18850	104	19041	115	19295	120	19441	119	19561	185	19631	185
18851	104	19042	115	19297	121	19442	119	19562	185	19632	185
18852	104	19043	115	19301	123	19443	119	19562	185	19633	185
18853	104	19044	115	19303	118	19450	127	19563	185	19634	185
18855	104	19045	115	19306	123	19451	127	19564	185	19635	185
18856	104	19046	115	19308	123	19455	127	19565	185	19635	185
18860	104	19050	116	19310	123	19457	127	19565	185	19636	185
18861	104	19051	118	19312	123	19458	128	19567	185	19637	185
18862	104	19052	118	19314	123	19459	128	19568	185	19638	185
18863	104	19053	116	19326	123	19460	126	19568	185	19639	185
18864	104	19054	116	19328	123	19462	124	19569	185	19640	185
18865	104	19055	116	19330	123	19463	124	19570	185	19640	185
18866	104	19056	116	19332	123	19464	124	19570	185	19641	185
18867	104	19057	116	19333	123	19465	124	19573	185	19642	185
18868	105	19058	116	19335	123	19469	124	19574	185	19643	185
18869	105	19059	116	19337	123	19470	126	19575	185	19644	185
18870	105	19060	118	19340	122	19472	203	19575	185	19645	185
18871	105	19061	117	19356	124	19473	203	19576	185	19645	185
18872	105	19062	117	19357	124	19474	203	19577	185	19646	185
18873	105	19063	117	19370	123	19477	203	19578	185	19647	185
18874	105	19064	117	19371	123	19478	203	19579	185	19648	185
18900	108	19065	118	19374	124	19480	203	19580	185	19649	185
18901	108	19066	116	19380	122	19481	203	19580	185	19650	185
18905	108	19067	116	19381	122	19482	203	19581	185	19650	185
18906	108	19068	116	19382	122	19483	203	19583	185	19651	185
18907	109	19069	116	19383	122	19485	202	19584	185	19652	185
18909	108	19070	116	19384	122	19486	202	19585	185	19653	185
18910	100	19071	116	19385	122	19487	202	19585	185	19654	185
18915	109	19074	115	19387	122	19490	127	19586	185	19655	185
18916	109	19075	115	19388	122	19491	127	19587	185	19656	185
18920	84	19076	115	19389	122	19492	127	19588	185	19657	185
18921	84	19077	115	19390	123	19493	127	19589	185	19658	185
18922	84	19081	115	19391	122	19494	127	19590	185	19659	185
18925	84	19082	115	19392	123	19495	127	19590	185	19660	185
18926	84	19083	115	19393	124	19496	127	19591	185	19661	185
18927	84	19084	115	19394	124	19497	127	19593	185	19662	185
18928	84	19085	115	19395	124	19498	127	19594	185	19663	185
18929	84	19086	115	19396	124	19499	127	19595	185	19664	185
18930	84	19088	115	19397	124	19501	127	19595	185	19665	185
18931	84	19090	115	19398	119	19502	127	19596	185	19669	185
18934	84	19092	115	19399	119	19510	128	19597	185	19670	186
18937	84	19095	115	19400	126	19515	128	19598	185	19671	186
18939	84	19096	115	19401	126	19520	128	19599	185	19672	186
18944	84	19097	115	19402	126	19530	185	19600	185	19673	186
18945	84	19098	115	19403	126	19530	185	19600	185	19673	186
18948	84	19100	117	19404	126	19532	185	19601	185	19674	186
18950	84	19106	115	19405	126	19533	185	19603	185	19675	186
18951	84	19108	115	19406	126	19534	185	19604	185	19676	186
18954	84	19109	115	19407	126	19535	185	19605	185	19677	186
18955	84	19110	128	19408	126	19535	185	19605	185	19678	186
18956	84	19115	118	19409	126	19536	185	19606	185	19678	186

broj artikla	strana	broj artikla	strana	broj artikla	strana	broj artikla	strana	broj artikla	strana	broj artikla	strana
19679	186	19743	186	20235	187	20493	191	20767	194	20942	197
19680	186	19743	186	20240	187	20494	191	20768	194	20943	197
19681	186	19744	186	20245	187	20495	191	20769	194	20944	197
19682	186	19745	186	20250	187	20496	191	20770	194	20945	197
19683	186	19746	186	20255	187	20508	195	20771	194	20946	197
19683	186	19747	186	20260	187	20510	195	20772	194	20947	197
19684	186	19748	186	20270	187	20511	195	20773	194	20948	197
19685	186	19748	186	20280	187	20512	195	20774	194	20949	197
19686	186	19749	186	20290	187	20513	195	20775	194	20950	196
19687	186	19750	186	20296	187	20514	195	20776	194	20952	196
19688	186	19751	186	20300	189	20515	195	20777	194	20954	196
19688	186	19752	186	20305	189	20516	195	20778	194	20956	197
19689	186	19753	186	20310	189	20520	195	20779	194	20957	204
19690	186	19753	186	20311	189	20521	195	20780	194	20958	204
19691	186	19754	186	20315	190	20522	195	20781	194	20960	209
19692	186	19755	186	20316	189	20523	195	20782	194	20961	209
19693	186	19756	186	20317	189	20524	195	20783	194	20963	209
19693	186	19757	186	20320	190	20525	195	20784	194	20965	209
19694	186	19758	186	20321	190	20526	195	20785	194	20966	209
19695	186	19758	186	20333	188	20673	194	20786	194	20967	90
19695	186	19759	186	20334	188	20674	194	20787	194	20968	90
19696	186	19760	186	20335	188	20675	194	20788	194	20969	90
19697	186	19761	186	20336	188	20676	194	20789	194	20970	209
19698	186	19762	186	20337	188	20677	194	20790	194	20971	209
19698	186	19763	186	20338	188	20678	194	20791	194	20972	209
19699	186	19763	186	20350	203	20680	194	20792	194	20973	209
19700	186	19764	186	20360	180	20682	194	20793	194	20980	204
19701	186	19765	186	20361	180	20684	194	20794	194	20981	204
19701	186	19766	186	20363	71	20685	194	20795	194	20982	204
19702	186	19767	186	20365	209	20686	194	20796	194	20983	204
19703	186	19768	186	20379	199	20687	194	20797	194	20984	204
19703	186	19768	186	20380	190	20688	194	20798	194	20990	197
19704	186	19769	186	20381	208	20690	194	20799	194	20991	197
19705	186	19770	186	20385	193	20691	194	20805	195	20992	197
19705	186	19771	186	20386	193	20692	194	20820	195	20999	195
19706	186	19772	186	20387	193	20694	194	20825	194	21010	236
19707	186	19772	186	20390	193	20696	194	20855	194	21011	236
19708	186	19773	186	20391	193	20697	194	20861	194	21012	236
19708	186	19774	186	20395	193	20698	194	20862	194	21015	236
19709	186	19775	186	20396	193	20724	204	20870	194	21018	236
19710	186	19776	186	20397	193	20725	204	20871	194	21023	236
19711	186	19776	186	20400	187	20726	204	20872	194	21110	236
19711	186	19777	186	20401	187	20727	204	20873	194	21111	236
19712	186	19778	186	20402	187	20728	204	20874	194	21112	236
19713	186	19779	186	20403	187	20729	204	20875	194	21115	236
19713	186	19780	186	20404	187	20730	204	20876	194	21118	236
19714	186	19781	186	20405	187	20731	204	20877	194	21123	236
19715	186	19781	186	20406	187	20732	204	20878	194	21130	236
19716	186	19782	186	20407	187	20733	204	20879	194	21135	236
19717	186	19783	186	20408	187	20734	204	20880	194	21140	236
19718	186	19783	186	20409	187	20735	204	20881	194	21150	236
19718	186	19784	186	20410	187	20736	204	20890	195	21180	236
19719	186	19785	186	20411	187	20737	204	20891	195	21190	236
19720	186	19786	186	20412	187	20738	204	20895	195	21192	239
19721	186	19786	186	20413	187	20739	204	20896	204	21194	239
19722	186	19787	186	20414	187	20740	204	20897	204	21195	237
19723	186	19788	186	20415	187	20741	204	20898	204	21200	234
19723	186	19789	186	20416	187	20743	106	20899	204	21201	234
19724	186	19790	186	20417	187	20743	197	20901	205	21203	234
19725	186	19791	186	20418	187	20744	197	20905	204	21204	234
19726	186	19792	186	20419	187	20744	208	20910	204	21210	234
19727	186	19793	186	20420	187	20745	208	20911	204	21211	234
19728	186	19794	186	20421	187	20748	194	20912	204	21212	234
19728	186	19795	186	20422	187	20749	194	20913	204	21215	234
19729	186	19796	186	20423	187	20750	194	20915	204	21218	234
19730	186	19797	186	20424	187	20751	194	20916	204	21219	234
19731	186	19798	186	20425	187	20752	194	20917	204	21220	234
19732	186	19799	186	20426	187	20753	194	20918	204	21223	234
19733	186	19800	186	20427	187	20754	194	20919	204	21224	234
19733	186	19801	186	20428	187	20755	194	20920	204	21301	235
19734	186	19802	186	20429	187	20756	194	20921	204	21303	235
19735	186	19841	187	20430	187	20757	194	20922	204	21306	239
19736	186	19842	187	20450	205	20758	194	20923	204	21308	239
19737	186	19845	187	20460	205	20759	194	20924	204	21311	235
19738	186	19885	187	20487	191	20760	194	20936	196	21312	235
19738	186	19895	187	20488	191	20761	194	20937	197	21315	235
19739	186	20210	205	20489	191	20762	194	20938	197	21318	235
19740	186	20220	187	20490	191	20764	194	20939	197	21323	235
19741	186	20225	187	20491	191	20765	194	20940	197	21324	235
19742	186	20230	187	20492	191	20766	194	20941	197	21326	235

broj artikla	strana	broj artikla	strana	broj artikla	strana	broj artikla	strana	broj artikla	strana	broj artikla	strana
21327	235	21803	240	22031	212	22113	218	22222	238	22535	184
21410	235	21804	240	22032	212	22115	218	22224	238	22540	184
21411	235	21810	216	22033	213	22116	218	22225	238	22542	184
21412	235	21811	216	22034	213	22117	218	22228	238	22545	184
21415	235	21812	216	22035	213	22120	219	22229	238	22548	184
21418	235	21813	216	22036	213	22121	219	22230	239	22550	184
21423	235	21814	216	22037	211	22122	219	22232	239	22555	184
21424	235	21831	216	22038	211	22123	219	22234	239	22560	184
21425	237	21832	216	22039	211	22124	219	22236	239	22565	184
21426	237	21834	216	22040	211	22125	219	22238	239	22568	184
21427	237	21850	218	22041	214	22126	219	22240	238	22570	184
21428	237	21851	218	22042	214	22129	219	22242	238	22575	184
21430	237	21852	218	22043	214	22130	219	22244	238	22580	184
21431	237	21853	218	22044	214	22132	219	22246	238	22585	184
21432	237	21854	218	22045	216	22133	219	22248	238	22590	184
21440	204	21855	218	22046	216	22134	219	22251	238	22595	184
21441	204	21856	218	22047	216	22135	381	22252	238	22600	184
21442	204	21857	218	22048	216	22136	381	22253	238	22602	184
21443	204	21858	218	22049	216	22137	381	22254	238	22605	184
21444	204	21859	218	22050	216	22138	381	22255	238	22610	184
21445	204	21860	218	22051	216	22140	241	22258	238	22615	184
21446	204	21861	218	22052	216	22141	241	22259	238	22620	184
21450	205	21862	218	22053	216	22142	241	22260	238	22625	184
21451	205	21863	218	22054	216	22143	241	22263	238	22630	184
21452	205	21864	218	22055	216	22145	241	22264	238	22701	214
21453	206	21900	210	22056	216	22146	241	22266	238	22702	214
21454	206	21901	210	22057	216	22147	241	22269	238	22703	214
21530	205	21902	210	22058	212	22148	241	22270	238	22704	214
21540	206	21903	210	22059	212	22150	241	22273	238	22705	214
21541	206	21904	210	22060	214	22151	241	22274	238	22706	214
21701	217	21905	210	22061	214	22155	241	22275	238	22707	214
21702	217	21906	210	22062	214	22156	241	22277	238	23000	400
21703	217	21907	211	22063	214	22158	213	22280	238	23001	400
21704	217	21908	211	22064	214	22159	213	22281	238	23005	402
21705	217	21909	211	22065	215	22160	216	22285	239	23006	402
21706	217	21910	211	22066	215	22161	216	22286	239	23010	402
21709	217	21911	211	22067	217	22162	216	22294	239	23020	402
21715	217	21912	211	22068	215	22163	216	22300	222	23025	402
21716	217	21913	211	22069	215	22164	216	22301	222	23030	402
21717	217	21914	211	22070	215	22166	216	22302	222	23035	402
21718	217	21920	210	22071	215	22167	216	22303	222	23040	402
21719	217	21925	210	22072	215	22168	216	22305	222	23050	402
21720	217	21926	210	22073	214	22170	221	22307	222	23060	402
21721	217	21930	212	22074	214	22171	221	22309	222	23070	402
21724	217	21931	212	22075	217	22172	221	22310	222	23125	401
21732	217	21935	212	22076	217	22173	221	22311	222	23130	401
21734	217	21936	212	22077	217	22174	221	22312	222	23135	401
21735	217	21937	212	22078	213	22178	220	22313	222	23140	401
21736	217	21940	212	22079	213	22180	220	22314	222	23150	401
21737	217	21941	212	22080	213	22181	220	22315	222	23160	401
21740	217	22001	210	22081	213	22182	220	22317	222	23211	401
21741	217	22002	210	22082	213	22183	220	22318	222	23212	401
21742	217	22003	210	22083	215	22184	220	22319	222	23213	401
21743	217	22004	211	22084	215	22185	220	22320	222	23214	401
21744	217	22005	211	22085	215	22186	220	22322	222	23215	401
21750	217	22006	211	22086	213	22188	221	22324	222	23220	401
21751	217	22007	210	22087	214	22189	221	22326	222	23225	401
21752	217	22008	210	22088	215	22190	221	22328	222	23232	401
21753	217	22009	210	22090	215	22195	221	22329	222	23240	401
21754	217	22010	210	22091	215	22197	221	22332	222	23250	401
21780	241	22011	210	22092	215	22198	221	22333	222	23260	401
21781	241	22012	211	22093	215	22199	221	22335	222	23261	401
21782	241	22013	211	22095	215	22200	199	22337	222	23262	401
21783	241	22014	211	22096	216	22201	199	22340	222	23263	401
21784	241	22015	211	22097	216	22202	221	22343	222	23264	401
21786	241	22016	211	22098	216	22203	221	22345	222	23265	401
21787	241	22017	211	22099	216	22204	221	22350	222	23266	401
21788	241	22018	212	22100	218	22205	221	22351	222	23274	401
21789	241	22019	212	22101	218	22206	220	22355	222	23275	401
21790	241	22020	212	22102	218	22207	220	22357	222	23281	403
21792	241	22021	212	22103	218	22208	220	22365	222	23282	403
21793	241	22022	212	22104	218	22209	220	22370	222	23284	403
21794	241	22023	211	22105	218	22211	238	22398	222	23287	402
21795	241	22024	211	22106	218	22212	238	22399	222	23288	402
21796	241	22025	211	22107	218	22215	238	22510	184	23290	403
21798	215	22026	212	22108	218	22216	238	22515	184	23291	403
21798	241	22027	212	22109	218	22217	238	22520	184	23292	403
21800	240	22028	212	22110	218	22218	238	22525	184	23297	403
21801	240	22029	212	22111	218	22219	238	22530	184	23310	401
21802	240	22030	212	22112	218	22220	238	22532	184	23311	401

broj artikla	strana	broj artikla	strana	broj artikla	strana	broj artikla	strana	broj artikla	strana	broj artikla	strana
23312	401	23735	139	24001	137	24148	230	24483	192	24779	201
23390	403	23736	441	24002	137	24149	230	24650	200	24780	201
23391	403	23736	139	24005	137	24150	231	24655	201	24781	201
23400	133	23760	130	24006	137	24151	231	24658	201	24782	201
23401	133	23761	130	24007	136	24152	232	24670	200	24783	201
23402	133	23762	130	24010	136	24152	339	24671	200	24784	201
23406	133	23763	130	24015	137	24153	228	24672	200	24785	201
23407	133	23764	130	24017	137	24154	231	24673	200	24786	201
23410	133	23800	130	24020	137	24155	233	24674	200	24787	201
23411	133	23810	410	24030	137	24156	233	24675	200	24788	201
23412	133	23814	410	24035	138	24158	233	24676	200	24789	201
23415	133	23816	410	24036	138	24159	219	24690	209	24790	200
23416	133	23818	410	24038	138	24159	233	24691	209	24791	200
23417	133	23820	410	24039	138	24160	227	24695	209	24792	200
23420	133	23824	410	24040	138	24161	227	24700	200	24793	200
23506	132	23826	410	24041	138	24162	227	24701	200	24794	200
23507	132	23828	410	24042	138	24163	227	24702	200	24795	201
23508	132	23830	410	24043	138	24164	227	24703	200	24796	200
23515	132	23840	345	24045	224	24165	227	24704	200	24798	200
23520	132	23845	344	24050	226	24166	227	24705	200	25001	323
23525	132	23846	344	24055	223	24167	227	24706	207	25002	323
23530	132	23847	344	24055	282	24168	227	24712	207	25003	323
23531	132	23850	410	24060	223	24169	227	24713	208	25004	323
23551	132	23854	410	24061	223	24170	229	24714	208	25005	323
23560	131	23856	410	24062	223	24171	230	24715	208	25006	322
23561	131	23858	410	24063	223	24173	231	24716	208	25009	322
23562	131	23860	410	24064	223	24174	233	24717	198	25012	322
23563	131	23864	410	24065	223	24175	233	24718	198	25015	322
23564	131	23865	410	24066	223	24176	233	24719	198	25016	322
23565	131	23866	410	24067	223	24177	233	24720	208	25020	322
23566	131	23868	410	24068	223	24178	233	24721	208	25024	322
23570	131	23870	410	24069	223	24180	228	24722	208	25025	322
23571	131	23875	394	24070	223	24181	233	24723	198	25030	322
23572	131	23880	410	24071	223	24185	227	24725	198	25040	322
23573	131	23882	410	24072	223	24186	227	24726	198	25048	322
23574	131	23884	410	24073	223	24187	227	24727	295	25060	322
23585	132	23904	130	24074	223	24188	227	24728	295	25096	322
23587	132	23906	130	24075	223	24189	227	24729	295	25150	322
23589	132	23908	130	24076	223	24190	219	24730	197	25153	322
23591	132	23910	130	24077	223	24190	233	24731	197	25155	322
23600	132	23912	130	24078	223	24192	227	24732	197	25160	323
23601	132	23914	130	24080	224	24195	227	24735	199	25162	323
23602	132	23920	130	24081	224	24196	227	24736	199	25163	323
23605	132	23922	130	24082	224	24197	227	24737	199	25164	323
23620	132	23923	129	24083	224	24212	414	24738	199	25167	323
23625	132	23924	129	24084	224	24225	414	24739	199	25169	323
23626	132	23925	129	24085	224	24250	414	24740	199	25170	323
23628	132	23927	129	24086	224	24255	414	24741	199	25171	323
23630	132	23928	130	24087	224	24258	414	24743	199	25179	322
23632	132	23945	129	24098	224	24260	414	24745	198	25180	322
23650	134	23950	138	24099	224	24301	225	24746	199	25181	322
23655	134	23951	138	24100	228	24302	225	24747	198	25182	322
23657	135	23952	138	24102	228	24303	225	24748	199	25183	322
23657	278	23953	138	24104	228	24304	225	24749	199	25184	322
23660	134	23954	138	24108	227	24305	225	24750	192	25186	322
23670	131	23955	138	24109	228	24306	225	24751	192	25188	322
23671	131	23960	130	24110	229	24308	226	24752	295	25189	322
23672	131	23961	130	24111	229	24310	226	24753	295	25190	322
23673	131	23962	130	24118	228	24312	226	24755	206	25195	322
23674	131	23963	130	24119	228	24313	226	24756	206	25206	322
23675	131	23964	130	24120	227	24314	227	24757	198	25212	322
23676	131	23965	130	24121	229	24315	226	24758	198	25215	322
23677	131	23966	130	24122	229	24316	226	24759	198	25220	322
23678	131	23967	130	24124	229	24410	192	24760	200	25224	322
23679	131	23970	138	24125	229	24411	192	24761	200	25230	322
23680	131	23971	138	24126	229	24412	192	24762	200	25240	322
23681	131	23972	138	24128	231	24415	207	24763	200	25248	322
23682	131	23973	138	24130	230	24419	192	24764	200	25260	322
23683	131	23974	138	24131	230	24420	192	24765	200	25296	322
23684	131	23975	138	24133	230	24422	192	24766	200	25350	322
23685	131	23976	138	24135	231	24425	192	24767	200	25369	322
23730	441	23977	138	24136	231	24429	192	24768	200	25370	322
23730	139	23978	138	24137	231	24432	192	24769	200	25371	322
23731	441	23979	138	24140	231	24435	192	24770	199	25372	322
23731	139	23985	138	24141	231	24437	192	24771	199	25373	322
23732	441	23986	138	24142	231	24444	192	24772	199	25374	322
23732	139	23987	138	24143	230	24451	192	24773	199	25376	322
23734	441	23988	138	24144	230	24457	192	24774	199	25378	322
23734	139	23989	138	24145	230	24464	192	24776	200	25379	322
23735	441	24000	137	24147	230	24476	192	24778	201	25380	322

broj artikla	strana	broj artikla	strana	broj artikla	strana	broj artikla	strana	broj artikla	strana	broj artikla	strana
25400	323	26963	440	31146	244	31559	249	32318	257	33257	430
25410	323	26972	441	31148	244	31601	255	32319	257	33258	430
26028	44	26973	441	31150	245	31602	255	32320	257	33270	431
26037	49	26974	441	31151	245	31603	255	32321	257	33275	431
26201	46	26975	441	31155	245	31610	249	32322	257	33275	304
26204	46	26976	441	31218	248	31641	255	32323	257	33280	431
26209	47	26977	441	31220	246	31651	255	32324	257	33285	431
26211	47	26979	443	31221	246	31655	255	32325	258	33286	431
26215	44	26985	442	31222	246	32001	252	32326	258	33289	431
26216	45	26986	442	31231	246	32002	252	32327	256	33291	431
26217	45	26988	443	31232	246	32003	252	32328	258	33292	431
26218	45	26996	443	31233	246	32013	252	32329	257	33293	431
26520	48	26997	443	31234	246	32014	252	32330	258	33298	431
26521	48	26998	443	31235	246	32015	252	32331	258	33299	431
26528	49	28000	4	31270	247	32016	252	32332	256	34005	259
26700	438	28001	5	31271	247	32018	252	32333	256	34006	259
26701	438	28002	5	31280	247	32020	252	32335	258	34007	259
26702	438	28003	6	31281	247	32021	252	32337	256	34027	259
26705	438	28004	6	31320	247	32022	255	32338	256	34028	258
26705	326	28005	7	31322	247	32023	255	32418	257	34033	264
26706	438	28006	7	31330	247	32024	252	32421	257	34041	259
26706	326	28007	8	31332	247	32026	252	33100	426	34051	259
26707	438	28008	8	31334	246	32037	255	33102	426	34053	259
26707	326	28021	9	31340	247	32040	255	33105	426	34061	260
26720	438	28025	9	31341	247	32041	255	33107	426	34071	260
26720	326	28030	12	31343	246	32042	255	33110	426	34081	260
26721	438	28032	12	31360	246	32043	255	33112	426	34091	260
26721	326	28035	14	31362	246	32044	255	33113	426	34101	260
26722	438	28040	13	31380	246	32050	255	33114	426	34111	260
26722	326	28045	13	31382	246	32051	255	33120	426	34115	260
26775	297	28050	15	31390	246	32052	255	33123	426	34116	260
26780	304	28055	15	31392	246	32053	255	33124	426	34117	260
26781	304	28065	11	31400	246	32060	252	33127	427	34118	260
26782	304	28070	10	31402	246	32062	252	33131	427	34121	260
26783	304	28080	18	31403	246	32064	252	33132	427	34122	260
26800	434	28081	18	31404	246	32066	252	33135	427	34132	260
26801	434	28085	18	31452	254	32076	252	33137	427	34142	260
26802	434	28086	18	31453	254	32161	251	33140	427	34152	260
26803	434	28101	16	31454	254	32162	251	33141	427	34153	260
26804	434	28102	17	31455	248	32163	251	33142	427	34154	260
26805	434	28103	17	31456	248	32164	251	33143	427	34155	260
26806	434	28104	16	31461	248	32165	251	33150	427	34156	260
26807	434	30003	259	31467	248	32166	251	33151	427	34157	260
26815	434	30003	264	31468	248	32167	251	33152	427	34158	260
26816	434	30004	259	31471	248	32168	251	33154	427	34159	260
26817	434	30004	264	31481	248	32169	251	33155	430	34160	260
26819	434	30005	259	31491	248	32170	248	33160	428	34200	260
26820	435	30005	264	31493	250	32171	251	33162	428	34201	260
26824	435	30007	259	31494	250	32172	251	33163	428	34202	260
26825	435	30007	264	31495	250	32173	248	33164	428	34203	260
26826	435	31005	245	31496	250	32174	251	33165	428	34221	264
26829	436	31006	245	31497	254	32176	251	33167	428	34223	264
26844	435	31007	245	31498	250	32176	251	33168	428	34231	265
26845	435	31008	245	31499	250	32186	251	33168	257	34235	265
26853	436	31009	245	31500	250	32196	251	33169	428	34237	265
26857	436	31011	245	31501	254	32206	251	33170	428	34238	265
26858	436	31021	245	31502	254	32216	251	33170	428	34238	265
26859	436	31031	245	31503	254	32226	251	33200	429	34241	264
26862	436	31041	245	31503	254	32234	251	33201	429	34243	264
26871	437	31041	245	31505	248	32240	251	33202	429	34251	264
26871	437	31051	245	31506	248	32265	253	33203	429	34261	265
26880	437	31052	246	31507	248	32268	253	33205	429	34262	264
26881	437	31053	245	31510	248	32269	253	33206	429	34265	265
26886	437	31061	246	31511	248	32270	253	33207	429	34271	260
26888	437	31062	246	31512	248	32273	253	33208	429	34272	260
26891	441	31071	246	31513	248	32273	253	33209	429	34273	260
26895	439	31072	246	31514	248	32283	253	33210	429	34274	260
26896	439	31081	246	31515	248	32285	253	33211	429	34275	260
26897	439	31082	245	31515	248	32293	253	33211	429	34275	260
26911	440	31082	245	31520	250	32295	253	33212	429	34276	260
26912	440	31091	244	31521	250	32296	253	33215	429	34280	260
26912	440	31101	244	31522	250	32297	253	33215	429	34280	260
26914	440	31111	244	31522	250	32299	253	33220	430	34281	260
26915	440	31111	244	31523	250	32298	253	33221	430	34282	260
26920	438	31121	244	31524	250	32301	253	33246	431	34283	260
26920	438	31131	244	31541	250	32302	253	33247	431	34284	260
26921	438	31132	244	31551	250	32311	257	33248	431	34285	260
26922	438	31140	244	31552	250	32312	256	33249	431	34300	297
26940	439	31141	244	31553	250	32313	253	33250	430	34301	260
26941	439	31142	244	31555	249	32314	257	33252	430	34303	297
26943	439	31143	244	31556	249	32314	257	33252	430	34303	297
26954	440	31144	244	31557	249	32315	258	33254	430	34304	260
26961	440	31145	244	31557	249	32316	258	33255	430	34305	254
				31558	249	32317	256	33256	430	34306	254

broj artikla	strana	broj artikla	strana	broj artikla	strana	broj artikla	strana	broj artikla	strana	broj artikla	strana
34307	254	35081	268	35517	273	37041	255	37204	286	37500	274
34308	254	35082	269	35518	273	37051	255	37205	286	37501	274
34315	219	35085	267	35519	273	37053	284	37205	286	37505	274
34316	172	35086	267	35524	273	37054	284	37210	285	37506	274
34316	219	35087	267	35525	273	37055	284	37211	285	37509	275
34400	262	35091	267	35527	273	37065	290	37212	286	37510	275
34401	262	35092	267	35532	273	37066	290	37216	298	37511	275
34402	263	35093	267	35533	273	37067	290	37217	298	37512	275
34403	263	35094	267	35539	273	37068	290	37218	298	37515	275
34404	262	35095	267	35540	273	37069	290	37220	285	37516	275
34405	262	35096	267	35542	273	37070	290	37229	299	37517	275
34406	263	35103	270	35552	273	37094	290	37230	299	37518	275
34407	263	35113	270	35553	273	37095	290	37231	299	37527	276
34409	262	35123	270	35555	273	37096	290	37232	299	37530	276
34410	262	35125	270	35603	276	37097	290	37233	299	37532	276
34411	263	35126	270	35604	276	37098	290	37234	299	37533	276
34412	263	35127	270	35605	276	37101	255	37235	299	37539	276
34413	263	35300	266	35833	271	37111	255	37236	298	37541	276
34414	264	35310	266	35845	271	37114	298	37237	298	37545	279
34415	262	35311	266	35850	271	37115	298	37238	298	37546	279
34416	262	35316	266	36014	282	37117	283	37239	298	37549	279
34417	263	35317	266	36024	282	37119	298	37243	321	37553	135
34418	263	35318	266	36034	282	37120	298	37244	321	37553	278
34419	262	35319	266	36035	282	37121	304	37245	321	37560	279
34420	262	35320	314	36036	282	37122	304	37246	321	37564	277
34421	263	35322	314	36046	282	37123	421	37247	321	37570	231
34422	263	35323	181	36056	283	37124	421	37248	321	37570	279
34423	263	35323	294	36057	283	37125	288	37250	321	37600	327
34424	263	35325	181	36058	283	37126	288	37251	321	37601	327
34425	262	35325	294	36059	283	37127	288	37252	321	37602	327
34426	262	35326	181	36076	281	37129	421	37253	321	37603	327
34428	263	35326	294	36077	281	37130	287	37255	308	37604	327
34429	264	35327	181	36080	281	37131	287	37256	308	37605	327
34439	262	35327	294	36081	281	37132	287	37257	308	37606	327
34440	262	35328	181	36082	281	37135	443	37258	308	37611	327
34441	262	35328	294	36085	281	37135	154	37259	308	37615	327
34442	262	35329	181	36086	281	37139	154	37263	308	37616	327
34443	262	35329	294	36087	281	37140	154	37264	308	37621	419
34445	262	35330	183	36126	282	37141	154	37266	308	37630	419
34446	262	35330	293	36128	282	37142	154	37267	308	37640	418
34447	262	35331	183	36130	282	37143	154	37268	308	37641	418
34448	263	35331	293	36136	282	37144	154	37270	308	37645	418
34449	262	35332	182	36140	285	37145	154	37271	308	37650	419
34450	262	35332	292	36145	280	37148	286	37272	308	37730	270
34451	262	35333	182	36160	280	37149	286	37273	308	37731	270
34452	263	35333	292	36175	280	37150	286	37275	308	37760	270
34453	262	35334	182	36190	280	37151	286	37280	309	37761	270
34454	262	35334	292	36191	280	37152	286	37281	309	38000	312
34455	263	35335	181	36199	281	37153	286	37290	321	38001	311
34456	263	35335	294	36200	281	37154	286	37291	321	38002	312
34457	263	35336	182	36240	281	37155	286	37295	410	38003	312
34458	263	35336	292	36300	279	37156	286	37295	309	38004	312
34459	264	35345	183	36305	413	37157	286	37296	410	38005	312
34479	264	35345	293	36306	413	37158	286	37296	309	38006	311
34480	262	35346	183	36308	297	37162	288	37297	410	38007	312
34481	262	35346	293	36310	277	37166	277	37297	309	38008	312
34482	262	35347	183	36312	297	37170	288	37300	158	38009	312
34485	262	35347	183	36313	413	37171	288	37301	158	38010	311
34486	262	35347	293	36314	413	37172	288	37302	158	38012	311
34490	263	35347	293	36325	289	37173	288	37303	158	38013	311
34491	263	35348	182	37005	317	37174	288	37308	159	38014	312
34496	263	35348	292	37006	284	37175	288	37309	159	38014	312
34500	264	35360	144	37006	284	37176	288	37310	157	38015	313
35006	268	35361	144	37007	284	37177	289	37311	157	38016	313
35007	268	35362	144	37007	284	37178	289	37317	337	38017	313
35011	270	35500	272	37008	284	37185	288	37320	157	38018	313
35012	268	35501	272	37009	284	37186	288	37321	157	38020	311
35013	268	35502	272	37010	431	37187	288	37325	156	38021	313
35015	269	35503	272	37011	284	37188	288	37326	156	38022	313
35021	269	35504	272	37012	284	37189	288	37328	156	38024	311
35023	267	35505	272	37021	284	37190	288	37330	155	38025	311
35038	267	35506	272	37025	283	37195	286	37331	155	38026	286
35048	269	35507	272	37025	283	37196	286	37332	155	38026	314
35058	267	35508	272	37026	283	37197	286	37340	159	38027	310
35059	268	35510	272	37026	283	37198	286	37341	158	38028	310
35068	269	35511	272	37028	283	37199	287	37342	158	38030	314
35069	268	35512	272	37028	283	37200	286	37343	159	38031	313
35070	269	35514	273	37029	283	37201	286	37344	159	38042	286
35078	268	35515	273	37029	283	37202	286	37345	159	38042	314
35079	269	35516	273	37031	255	37203	286	37350	157	38050	305

broj artikla	strana	broj artikla	strana	broj artikla	strana	broj artikla	strana	broj artikla	strana	broj artikla	strana
38052	305	38980	307	41120	387	42368	305	45019	336	45096	333
38054	305	38981	307	41121	387	42420	296	45020	332	45097	333
38055	305	38985	309	41122	387	43050	395	45021	336	45098	333
38060	305	38990	307	41123	387	43058	396	45023	332	45099	333
38063	305	38991	307	41150	387	43060	396	45025	336	45100	364
38065	305	38995	308	41151	387	43068	396	45026	335	45101	364
38095	305	39000	304	41152	387	43071	395	45027	336	45102	364
38096	305	39001	304	41153	387	43072	395	45029	336	45104	364
38097	305	39002	304	42101	387	43077	395	45030	232	45105	364
38895	291	39003	304	42102	387	43082	396	45030	339	45106	364
38896	291	39005	304	42103	387	43083	396	45031	232	45107	364
38899	291	39010	304	42115	299	43084	396	45031	339	45108	364
38900	291	39012	304	42120	299	43086	396	45032	232	45110	352
38901	291	39014	304	42150	389	43087	397	45032	339	45111	352
38902	291	39020	304	42151	389	43089	397	45033	232	45112	353
38903	291	39021	304	42152	389	43090	397	45033	339	45113	352
38904	291	39045	304	42153	389	43097	396	45034	342	45114	352
38905	291	39065	304	42155	389	43098	397	45035	341	45115	352
38906	291	39090	304	42156	389	43099	397	45036	345	45116	352
38907	291	39145	304	42157	389	43300	385	45038	342	45117	351
38908	291	39165	304	42158	389	43301	385	45039	342	45118	351
38909	291	39190	304	42160	389	44041	345	45040	342	45120	352
38910	291	39192	304	42161	389	44042	345	45041	342	45122	352
38911	291	39192	347	42162	389	44043	345	45042	347	45123	351
38912	291	39193	304	42163	389	44050	345	45043	344	45124	351
38913	291	39193	347	42170	389	44053	347	45044	345	45125	351
38914	291	39194	305	42171	389	44950	176	45045	177	45126	351
38915	291	39195	305	42172	389	44950	340	45045	344	45130	355
38916	291	39196	305	42173	389	44955	342	45046	177	45131	355
38917	291	39197	305	42174	389	44960	347	45046	344	45132	355
38918	291	39198	305	42175	389	44965	368	45047	347	45133	356
38919	285	39199	305	42176	389	44970	336	45048	177	45134	353
38920	285	39200	305	42177	389	44971	336	45048	335	45135	355
38923	285	39201	305	42178	389	44972	332	45048	344	45136	356
38924	307	39202	305	42179	389	44980	332	45049	345	45137	356
38925	307	39203	305	42180	389	44980	332	45050	368	45138	354
38926	309	39204	305	42181	389	44980	334	45051	369	45139	354
38927	307	39205	305	42182	389	44981	332	45052	369	45140	353
38928	308	39206	295	42185	389	44981	332	45053	370	45141	354
38929	307	39207	295	42186	389	44981	333	45054	370	45142	353
38930	309	39208	295	42187	389	44981	334	45055	369	45143	354
38931	307	39210	295	42188	389	44982	333	45056	341	45144	355
38932	307	39212	295	42190	306	44982	333	45057	341	45145	355
38933	309	39214	295	42190	389	44982	334	45058	341	45146	357
38934	308	39216	295	42201	390	44983	333	45059	341	45147	358
38935	309	39217	295	42202	390	44983	333	45060	232	45150	358
38937	309	39218	295	42203	390	44983	334	45060	339	45151	359
38939	309	39219	295	42207	390	44984	334	45061	232	45152	357
38940	309	39238	296	42208	390	44984	335	45061	339	45153	357
38941	309	39240	295	42209	390	44984	335	45062	232	45154	357
38942	308	39241	295	42210	390	44985	334	45062	339	45155	358
38943	309	39242	295	42211	390	44985	335	45063	332	45156	358
38944	306	39243	295	42212	390	44986	334	45065	341	45158	358
38945	306	39244	295	42213	390	44987	334	45066	341	45159	359
38946	306	39245	296	42214	390	44988	334	45067	341	45160	358
38947	306	40050	388	42217	390	44989	334	45068	177	45161	359
38948	306	40051	388	42218	390	44991	334	45068	335	45162	357
38949	306	40052	388	42219	390	44992	334	45068	344	45163	358
38950	296	40053	388	42220	390	44995	338	45069	176	45164	359
38951	296	40054	388	42221	390	44996	334	45069	340	45167	358
38952	296	40055	388	42228	390	44997	335	45070	370	45168	359
38953	296	40056	388	42229	390	44998	335	45071	369	45169	359
38954	296	40057	388	42230	390	44999	337	45074	346	45170	361
38955	306	40058	388	42240	390	45000	337	45079	342	45171	361
38956	306	40059	388	42244	390	45001	337	45080	342	45172	361
38957	306	40060	388	42248	390	45002	338	45081	176	45172	361
38958	306	40075	388	42249	390	45003	338	45081	340	45173	361
38959	306	40076	388	42251	390	45005	338	45082	176	45173	361
38960	306	40077	388	42252	390	45006	338	45082	340	45174	361
38961	306	40100	387	42253	390	45007	338	45083	176	45175	360
38963	309	40120	387	42255	390	45008	338	45083	340	45176	360
38964	307	41050	387	42256	390	45009	338	45084	176	45177	360
38965	308	41080	387	42257	390	45010	335	45084	340	45178	360
38966	307	41081	387	42260	391	45011	337	45085	347	45179	359
38968	307	41082	387	42261	391	45012	337	45086	346	45180	353
38969	309	41083	387	42312	296	45014	335	45088	333	45181	353
38970	296	41100	387	42312	390	45015	337	45089	333	45182	360
38971	296	41101	387	42365	305	45016	336	45093	347	45183	360
38972	309	41102	387	42366	305	45017	334	45094	334	45184	359
38973	309	41103	387	42367	305	45018	335	45095	333	45185	359

broj artikla	strana	broj artikla	strana	broj artikla	strana	broj artikla	strana	broj artikla	strana	broj artikla	strana
45186	359	45296	353	45520	343	45651	345	48415	328	50541	153
45187	360	45297	354	45521	343	45652	345	48420	328	50542	153
45190	362	45298	353	45522	343	45653	345	48452	328	50544	153
45191	362	45299	354	45523	343	45654	345	48453	328	50549	152
45192	362	45300	361	45524	343	45655	345	48454	328	50550	150
45193	362	45301	361	45525	343	45656	345	48455	328	50551	150
45194	362	45320	369	45526	343	45657	345	48456	328	50553	150
45195	362	45321	370	45527	343	45658	345	48457	328	50554	150
45196	362	45323	368	45528	343	45659	345	48719	279	50555	153
45197	362	45323	382	45529	343	45660	345	48729	277	50556	150
45198	362	45325	368	45530	343	45661	345	48730	277	50557	152
45199	362	45326	368	45531	343	45662	345	48731	277	50558	152
45200	362	45327	367	45532	343	45663	345	50004	414	50559	150
45203	363	45328	367	45533	343	45664	345	50005	414	50560	150
45204	363	45329	367	45534	343	45670	345	50009	415	50562	150
45206	362	45330	385	45535	346	45671	345	50010	415	50563	150
45211	363	45331	385	45540	346	45672	345	50011	415	50564	150
45213	355	45345	361	45541	346	45673	345	50012	415	50570	150
45214	357	45349	361	45542	346	48001	145	50013	415	50571	150
45215	356	45350	361	45543	346	48002	145	50014	415	50585	153
45216	357	45353	361	45550	346	48005	146	50015	415	50585	321
45217	357	45360	361	45551	346	48006	146	50017	417	50586	153
45218	356	45364	361	45552	346	48007	146	50019	417	50586	321
45219	356	45366	361	45553	346	48008	147	50020	417	50587	153
45220	363	45370	177	45555	346	48009	147	50021	417	50587	321
45221	363	45370	344	45556	346	48010	147	50022	417	50588	153
45222	363	45385	348	45557	346	48015	145	50025	417	50588	321
45223	363	45386	348	45558	346	48020	146	50026	417	50900	409
45224	363	45388	348	45559	346	48021	146	50030	391	50901	409
45225	363	45389	348	45560	345	48022	146	50031	391	50902	409
45226	363	45390	349	45562	346	48030	146	50032	391	50905	409
45227	363	45391	349	45563	346	48031	147	50033	391	50906	409
45228	363	45392	349	45564	346	48032	147	50035	443	50907	409
45229	363	45393	349	45565	346	48033	147	50035	391	50909	409
45239	366	45394	349	45570	389	48034	147	50036	443	50910	409
45240	366	45395	349	45571	389	48036	145	50036	391	50911	409
45241	366	45396	349	45572	389	48037	146	50037	391	50915	409
45242	366	45397	349	45573	389	48040	147	50038	391	50916	409
45244	365	45398	350	45580	390	48041	147	50040	391	50917	409
45245	365	45399	350	45600	363	48042	147	50041	391	50918	409
45246	365	45400	350	45601	363	48043	147	50042	391	50919	409
45247	365	45401	350	45602	363	48046	146	50050	305	50920	409
45248	365	45450	394	45603	363	48046	147	50050	305	51001	408
45249	365	45451	394	45604	363	48047	146	50051	305	51002	408
45250	365	45452	394	45605	363	48047	147	50052	305	51003	408
45251	365	45453	394	45606	363	48050	148	50052	305	51004	408
45253	365	45460	394	45607	363	48051	148	50100	324	51007	408
45254	365	45461	394	45608	363	48054	148	50101	324	51008	408
45256	365	45462	394	45609	363	48055	148	50102	324	51009	408
45257	365	45463	394	45610	363	48056	148	50103	324	51010	408
45260	365	45465	394	45611	363	48057	148	50104	324	51011	408
45261	365	45466	394	45612	363	48060	148	50106	324	51013	407
45262	365	45467	394	45613	363	48061	148	50108	324	51015	408
45262	366	45470	394	45614	363	48062	148	50500	151	51017	407
45263	365	45471	309	45615	363	48063	148	50501	151	51018	407
45263	366	45471	344	45616	363	48064	148	50502	151	51020	407
45265	366	45472	344	45617	363	48065	148	50503	151	51022	407
45266	366	45473	344	45618	363	48066	148	50505	151	51023	407
45267	365	45480	394	45619	363	48067	148	50510	149	51026	406
45267	366	45485	394	45620	363	48068	148	50511	149	51030	407
45268	365	45490	380	45621	363	48070	148	50512	149	51032	407
45268	366	45496	394	45622	363	48071	148	50513	149	51034	407
45269	366	45497	394	45623	363	48072	148	50514	149	51036	408
45270	365	45498	394	45624	363	48075	148	50518	151	51037	408
45271	365	45499	394	45625	363	48076	148	50519	151	51038	409
45272	365	45500	343	45626	363	48077	148	50520	151	51040	406
45273	365	45502	343	45627	363	48080	148	50521	151	51041	406
45274	365	45503	343	45628	363	48081	148	50522	152	51042	406
45280	364	45505	343	45629	363	48085	148	50523	151	51043	406
45283	364	45506	343	45630	363	48086	148	50524	151	51045	407
45285	364	45508	343	45631	363	48087	148	50525	152	51046	407
45286	364	45509	343	45632	363	48090	148	50526	152	51050	409
45287	364	45511	343	45633	363	48091	148	50527	153	51051	409
45289	355	45512	343	45634	363	48093	148	50529	152	51055	409
45290	355	45513	343	45635	363	48094	148	50531	152	51056	409
45291	355	45515	343	45636	363	48095	148	50532	153	51057	409
45292	356	45516	343	45637	363	48096	148	50533	152	51060	406
45293	356	45517	343	45638	363	48097	148	50537	152	51065	406
45294	354	45518	343	45639	363	48410	328	50539	152	51070	406
45295	354	45519	343	45650	345	48411	328	50540	153	51071	406

broj artikla	strana	broj artikla	strana	broj artikla	strana	broj artikla	strana	broj artikla	strana	broj artikla	strana
51072	406	51288	325	52125	385	55041	143	55465	392	61077	380
51100	326	51300	324	52126	385	55050	143	55640	329	61079	380
51101	326	51301	324	52130	285	55051	143	55642	329	61085	342
51102	326	51302	324	52160	382	55060	143	55645	329	61088	374
51103	326	51303	324	52161	382	55080	143	60001	384	61089	373
51104	326	51304	324	52162	382	55100	143	60006	384	61090	374
51105	326	51305	324	52163	382	55120	143	60008	384	61097	376
51106	326	51306	324	52164	382	55140	143	60012	384	61098	376
51107	326	51307	324	52168	381	55160	143	60018	385	61111	378
51108	326	51308	324	52173	381	55180	143	60019	385	61112	378
51109	326	51320	324	52175	381	55181	143	60020	385	61114	378
51110	326	51321	324	52176	381	55200	143	60022	385	61120	378
51111	326	51322	324	52185	382	55201	143	60100	253	61121	378
51120	326	51323	324	52186	382	55220	143	60115	277	61130	369
51121	326	51324	324	52187	382	55221	143	60116	277	61131	369
51122	326	51325	324	52188	382	55240	143	60117	277	61132	369
51123	326	51327	324	52189	382	55300	143	60118	277	61133	369
51124	326	51338	326	52190	382	55301	143	60121	277	61134	370
51125	326	51341	326	52191	382	55311	143	60123	277	61135	370
51126	326	51348	326	52192	382	55313	143	60201	384	61136	367
51127	326	51402	325	52193	382	55314	143	60206	384	61137	367
51130	326	51403	325	52194	382	55315	143	60208	384	61138	367
51131	326	51404	325	52195	383	55316	143	60212	384	61139	368
51132	326	51405	325	52196	383	55317	143	61000	374	61140	368
51181	415	51406	325	52197	382	55318	143	61001	374	61141	370
51182	415	51407	325	52198	381	55319	143	61002	375	61142	370
51187	409	51408	325	52202	316	55331	143	61003	376	61143	371
51196	326	51410	325	52203	316	55332	143	61004	375	61144	371
51197	326	51412	325	52204	316	55333	143	61005	372	61145	371
51198	326	51413	325	52205	316	55334	143	61006	372	61146	371
51199	326	51414	325	52206	316	55335	143	61007	373	61147	367
51200	409	51415	325	52207	316	55336	143	61008	372	61148	367
51201	409	51416	325	52208	316	55337	143	61009	377	61149	368
51202	409	51417	325	52212	316	55339	143	61010	373	61149	382
51203	409	51418	325	52213	316	55340	143	61012	377	61150	369
51204	324	51420	325	52214	316	55341	143	61013	376	61155	372
51205	324	51430	325	52215	316	55342	143	61014	377	61156	372
51206	324	51431	325	52216	316	55350	143	61015	373	61157	372
51207	324	51432	325	52217	316	55351	143	61018	376	61158	372
51208	324	51433	325	52218	316	55352	143	61019	376	61161	375
51209	324	51435	325	52220	316	55353	143	61020	374	61162	376
51210	324	51436	325	52283	316	55354	143	61021	373	61163	376
51211	324	51450	325	52284	316	55355	143	61022	374	61164	377
51212	324	51510	403	52285	316	55356	143	61024	375	61165	377
51220	325	51511	403	52286	316	55357	143	61025	373	61166	377
51221	325	51512	403	52288	316	55358	143	61026	373	61169	253
51222	325	51513	403	52305	319	55359	143	61028	377	61171	385
51225	325	51514	403	52306	319	55360	143	61029	373	61172	382
51226	325	51515	403	52315	319	55361	143	61030	371	61172	385
51227	325	51516	403	52328	319	55362	143	61031	371	61173	385
51241	324	51517	403	52331	319	55400	392	61032	371	61174	385
51242	324	52010	416	52334	319	55401	392	61033	371	61175	385
51243	324	52011	249	52391	319	55402	392	61034	371	61176	385
51244	324	52011	320	52421	319	55403	392	61035	378	61177	385
51245	324	52012	416	52424	319	55404	392	61036	378	61183	386
51246	324	52020	416	52428	319	55405	392	61038	378	61184	386
51247	324	52030	416	52456	319	55406	392	61040	378	61189	386
51257	326	52030	260	52471	319	55420	392	61042	378	61190	386
51258	326	52050	328	52600	318	55421	392	61044	377	61192	385
51259	326	52055	328	52601	318	55422	392	61045	371	61193	385
51260	326	52060	328	52602	318	55423	392	61046	371	61194	385
51261	326	52065	328	52605	318	55424	392	61047	371	61195	386
51262	326	52070	316	52610	318	55425	392	61048	371	61200	385
51263	326	52071	317	52611	297	55429	392	61050	374	61201	385
51264	326	52075	317	52612	297	55430	392	61051	374	61201	385
51265	326	52076	317	52620	321	55431	392	61052	375	61202	386
51271	324	52077	317	52625	321	55432	392	61053	374	61203	377
51272	324	52078	317	52630	321	55433	392	61054	375	61204	386
51273	324	52101	382	52635	321	55436	392	61056	373	61205	386
51274	324	52102	382	52640	321	55437	392	61057	373	61207	386
51275	324	52103	382	52645	321	55450	393	61058	375	61208	386
51276	324	52104	382	52652	321	55452	393	61059	375	61209	377
51278	324	52105	382	52656	321	55453	393	61060	371	61215	386
51280	325	52108	382	52662	320	55454	393	61061	371	61218	253
51281	325	52109	383	52666	320	55455	393	61062	371	61219	386
51282	325	52113	383	52671	320	55456	393	61063	371	61221	379
51283	325	52114	383	52694	320	55457	393	61067	379	61221	379
51284	325	52115	383	52695	320	55460	393	61068	379	61221	379
51286	325	52116	383	54008	321	55461	393	61069	379	61221	379
51287	325	52119	381	55040	143	55462	393	61070	379	61222	377

broj artikla	strana	broj artikla	strana	broj artikla	strana	broj artikla	strana	broj artikla	strana	broj artikla	strana
61223	376	70036	140	81152	424	81267	423	81348	423	81430	423
61224	378	70037	140	81155	424	81268	423	81349	423	81431	423
61224	378	70038	140	81160	425	81269	423	81350	423	81432	423
61230	386	70040	140	81165	425	81270	423	81351	423	81433	423
61235	416	70045	140	81170	424	81271	423	81352	423	81434	423
61240	118	70046	140	81175	425	81272	423	81353	423	81435	423
61250	386	70060	141	81178	425	81273	423	81354	423	81436	423
61251	347	70061	141	81180	425	81274	423	81355	423	81437	423
61251	386	70062	141	81185	424	81275	423	81356	423	81438	423
61252	386	70063	141	81186	424	81276	423	81357	423	81439	423
61253	386	70064	141	81189	424	81277	423	81358	423	81440	423
61254	386	70065	142	81190	425	81278	423	81359	423	81441	423
61255	386	70066	141	81191	425	81279	423	81360	423	81442	423
61256	386	70070	142	81200	423	81280	423	81361	423	81443	423
61290	379	70075	142	81201	423	81281	423	81362	423	81444	423
61291	379	70090	142	81202	423	81282	423	81363	423	81445	423
61292	379	70091	142	81203	423	81284	423	81364	423	81447	423
61293	379	70092	142	81204	423	81285	423	81365	423	81448	423
61294	379	70093	142	81205	423	81286	423	81366	423	81449	423
61295	379	70094	142	81206	423	81287	423	81367	423	81450	423
61296	379	70095	142	81207	423	81288	423	81370	423	81451	423
61297	379	70096	142	81208	423	81289	423	81371	423	81452	423
61299	393	70098	92	81209	423	81290	423	81372	423	81453	423
61300	393	70100	405	81210	423	81291	423	81373	423	81454	423
61301	393	70101	405	81211	423	81292	423	81374	423	81455	423
61302	393	70102	405	81212	423	81293	423	81375	423	81456	423
61320	119	70103	405	81213	423	81294	423	81376	423	81457	423
61321	119	70104	405	81214	423	81295	423	81377	423	81458	423
61322	119	70105	405	81215	423	81296	423	81378	423	81459	423
61323	119	70106	405	81216	423	81297	423	81379	423	81460	423
61324	119	70107	405	81217	423	81298	423	81380	423	81461	423
61325	119	70108	405	81218	423	81299	423	81381	423	81462	423
61326	119	70109	405	81219	423	81300	423	81382	423	81463	423
61327	119	70110	405	81220	423	81301	423	81383	423	81466	423
61328	119	70120	404	81221	423	81302	423	81384	423	81467	423
61329	119	70121	404	81222	423	81303	423	81385	423	81468	423
61330	119	70122	404	81223	423	81304	423	81386	423	81469	423
61331	119	70123	404	81224	423	81305	423	81387	423	81470	423
61340	123	70124	404	81225	423	81306	423	81388	423	81471	423
61341	123	70125	404	81226	423	81307	423	81389	423	81472	423
61342	123	70140	404	81227	423	81308	423	81390	423	81473	423
61343	123	70141	404	81228	423	81309	423	81391	423	81486	423
61344	123	70220	414	81229	423	81310	423	81392	423	81600	421
61345	123	70221	414	81230	423	81311	423	81393	423	81603	421
61346	123	81011	422	81231	423	81312	423	81394	423	82105	299
65062	329	81011A	422	81232	423	81313	423	81395	423	89970	411
65063	329	81011F	422	81233	423	81314	423	81396	423	89970	315
65064	329	81011G	422	81234	423	81315	423	81397	423	89973	411
65065	329	81011H	422	81235	423	81316	423	81398	423	89973	315
69900	301	81011R	422	81236	423	81317	423	81399	423	89975	411
69901	301	81012	422	81237	423	81318	423	81400	423	89975	315
69902	301	81013	422	81238	423	81319	423	81401	423	89980	411
69903	301	81014	422	81239	423	81320	423	81402	423	89980	315
69904	300	81015	422	81240	423	81321	423	81403	423	89985	411
69905	301	81016	422	81241	423	81322	423	81404	423	89985	315
69906	301	81022	422	81242	423	81323	423	81405	423	89987	411
69907	303	81023	422	81243	423	81324	423	81406	423	89987	315
69908	303	81024	422	81244	423	81325	423	81407	423	89988	411
69909	303	81025	422	81245	423	81326	423	81408	423	89988	315
69910	302	81035	422	81246	423	81327	423	81409	423	89989	411
69911	302	81036	422	81247	423	81328	423	81410	423	89989	315
69912	302	81053	420	81248	423	81329	423	81411	423	89990	411
69914	301	81054	420	81249	423	81330	423	81412	423	89990	315
69917	302	81056	420	81250	423	81331	423	81413	423	90070	283
69918	300	81057	420	81251	423	81332	423	81414	423	90071	283
69919	300	81070	420	81252	423	81333	423	81415	423	90072	283
69920	303	81071	420	81253	423	81334	423	81416	423	90191	185
69923	303	81072	420	81254	423	81335	423	81417	423	90192	186
69928	303	81074	420	81255	423	81336	423	81418	423		
69930	302	81075	420	81256	423	81337	423	81419	423		
69931	302	81077	420	81257	423	81338	423	81420	423		
70020	140	81100	420	81258	423	81339	423	81421	423		
70021	140	81101	420	81259	423	81340	423	81422	423		
70025	140	81102	420	81260	423	81341	423	81423	423		
70026	140	81103	420	81261	423	81342	423	81424	423		
70030	140	81104	420	81262	423	81343	423	81425	423		
70031	140	81105	420	81263	423	81344	423	81426	423		
70032	140	81106	420	81264	423	81345	423	81427	423		
70033	140	81150	424	81265	423	81346	423	81428	423		
70035	140	81151	424	81266	423	81347	423	81429	423		

LISTA KORIŠĆENIH IKONA

· SPECIFIKACIJE



SPECIFIKACIJE APLIKACIJE ·

- drvo ·
- keramika ·
- plastični ·
- aluminijum ·
- bakar ·
- kamen ·
- staklo ·
- zid ·
- papir ·
- čelik ·
- kompozit ·
- pločice ·
- nerđajući čelik ·
- malter ·
- drvo sa vijcima, ekseri ·
- gips karton ·
- za tucanje materijala za zateznom snagom do... ·

- S2** · functional parts made of high-alloy tool steels S2
- HSS** · functional parts made of high-speed steel
- Cr-Mo** · functional parts from chrome-molybdenum steel
- CrV** · functional parts from chrome-vanadium steel
- INOX** · functional parts from stainless steel
- NYLON** · najlonska drška
- TEFLON** · teflon surface
- Zn** · Zn sloj
- TiN** · TiN sloj
- HRC 58-61** · Tvrdća materijala (Rockwell)
- 40% PES** · napravljeno od 40% polyester
- PES** · napravljeno od polyester
- dijamantna zrna
- magnetno

- SDS+** **SDS MAX** **M14** · sistem stezanja
- broj zuba u ratchetu
- 1/2"** **3/4"** **1/4"** · montažna veličina
- 27 dB** · informacije o zaštiti sluha
- DIN 3113** **IP 54** · standard
- 32x** · broj proizvoda u kompletu
- II. class** **III. class** · klasa tačnosti
- pogodno za hladno vreme
- ERGO HANDLE** · ergonomska drška
- HOBBY** · hobi
- 2x AAA** · vrsta i broj potrebnih baterija
- UV STABLE** · uv stabilno
- RUBBER ENDS** · gumeni krajevi otporni na sudar



· AMBALAŽA I ZALIHE

- spakovano u kutiju
- euroslot
- MOQ 12** · minimalna količina porudžbine
- 5** · broj komada u pakovanju

AQUATIC FESTA A ROSA SPECIFIKACIJE ·

podesive šare raspršivanja ·

- minimalni i maksimalni pritisak ·
- maksimalni protok vode ·
- navodnjavana površina ·
- veličina navoja adaptera ·
- prečnik creva ·



20

23

24



ПРОФЕСИОНАЛНИ АЛАТИ



festatools



#festatools



festatools

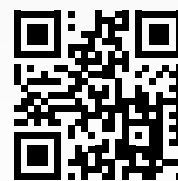

www.festa.tools

HORIZONT.

FESTA
POWER X TOOLS

FESTA
AQUATIC

ROSA KOMELON.

KDS

Stahlberg

SUPER PRO

Cescha

